

No.	DESCRIPTION	MATERIAL
1	SPUD	CAST LOW LEAD BRASS ALLOY
2	CTS GSKT	ASTM D2000(SBR)&410 STAINLESS STEEL
3	CONN NUT	CAST BRASS ASTM B62 ALLOY C83600
4	COMP GASKET	BUNA N ASTM D2000
5	WASHER	POLYPROPYLENE
6	CLPG NUT SUB	CAST BRASS ASTM B62 ALLOY C83600

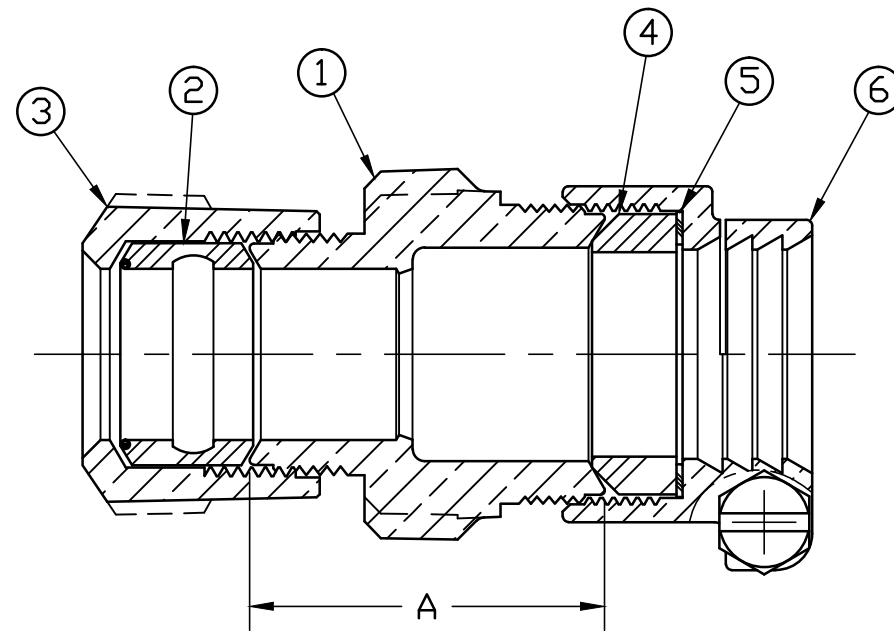

SIZE	A
3/4	1.85
3/4 x 1	2.14
1	2.15
1 x 3/4	2.06

NOTE: ALL WETTED PARTS ARE LOW LEAD BRASS ALLOY

FILEPATH: PROD-ENG\MUELLER\ASYSUBMITTALS\E15409N

DRFTR	RWB	2/22/16	Mueller Co.		
CHKR					
ENGR					
MGR					
			UNLESS OTHERWISE NOTED	THIRD ANGLE PROJECTION	
			SURFACE PREPARATION:		
			BREAK CORNER(S) ---- .000		
			SURFACE FINISH -- XX RMS	REF. No.	
			TOLERANCE(S):	SCALE	
			LINEAR ----- ± .000	NONE	
			ANGULAR ----- ± 0°00'		
			STK No:		
			MAT'L:		
			DESCR.		
			STRAIGHT LLB SERVICE FITTING	DWG NUMBER	
			(110 CTS x PEP PJ)	E15409N	
REV	ECR	DESCRIPTION	DATE	BY	CHKR
PER EST NO: DXXXX EST FIN WT = 0.0000 lbs					

DWG NUMBER
E15409N
442-MRKTNG

TITLE TO AND OWNERSHIP OF THIS ENGINEERING DATA REMAINS IN Mueller Co. NO USE IS TO BE MADE OF THIS DATA EXCEPT AS SPECIFICALLY AUTHORIZED BY Mueller Co. ASSENT ON THE PART OF THE RECIPIENT TO THESE CONDITIONS IS PRESUMED