

No.	DESCRIPTION	MATERIAL
1	90° FITTING	CAST LOW LEAD BRASS ALLOY
2	O-RING	ASTM D2000 (EP)
3	INSTA-TITE BODY	CAST LOW LEAD BRASS ALLOY
4	O-RING	ASTM D2000 (EP)
5	GRIP RING	CELCON M90 WHITE CF2001

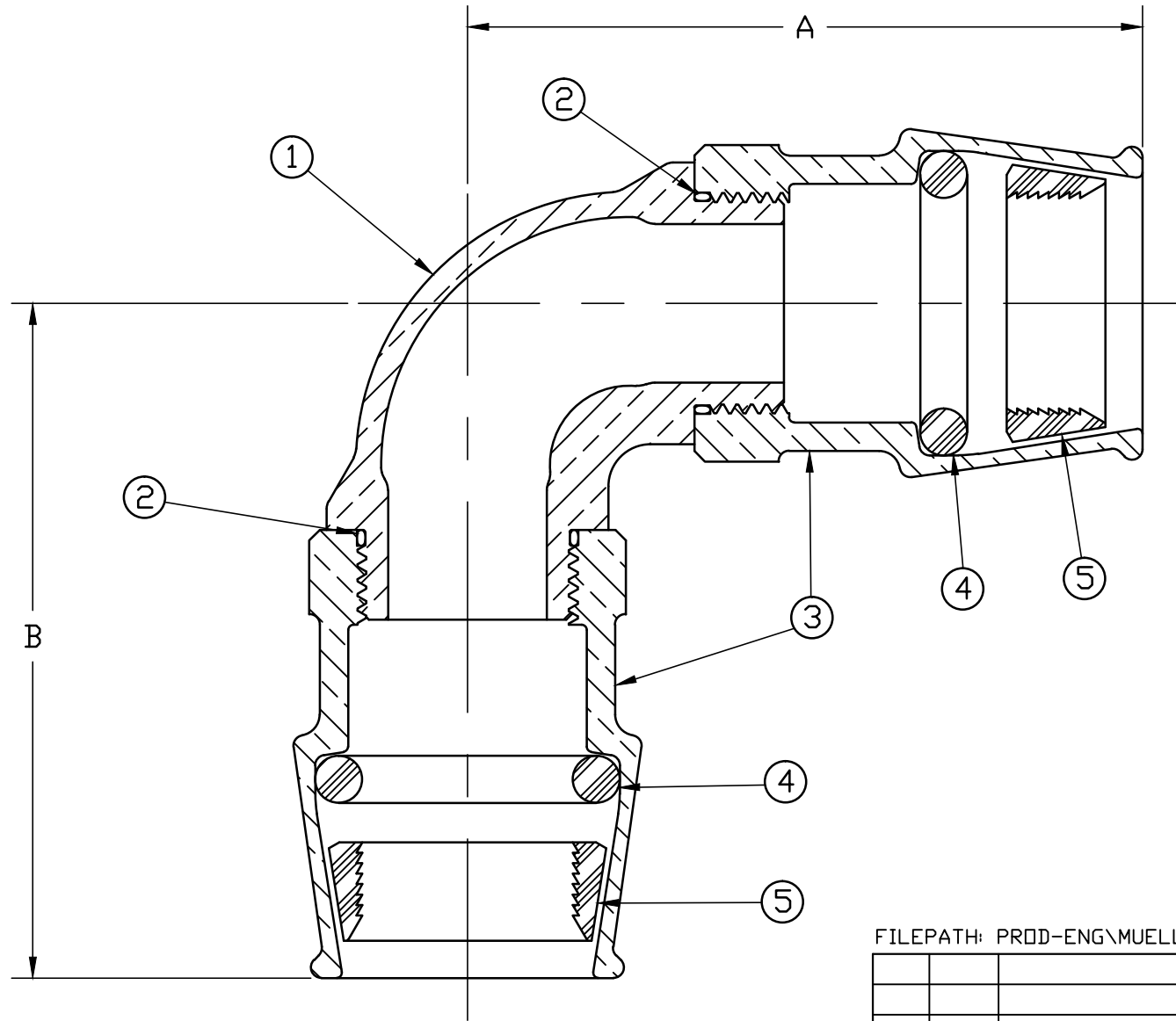

SIZE	A	B
3/4	3.84	3.84
1	4.00	4.00

NOTE: ALL WETTED PARTS ARE LOW LEAD BRASS ALLOY

FILEPATH: PROD-ENG\MUELLER\ASYSUBMITTALS\H15464N

DRFTR	RWB	11/7/14
CHKR		
ENGR		
MGR		
BY	DATE	
STK No:		
MAT'L:		
DESCR.		



UNLESS OTHERWISE NOTED
 SURFACE PREPARATION:
 BREAK CORNER(S) ---- .000
 SURFACE FINISH -- XX RMS
 TOLERANCE(S):
 LINEAR ----- ± .000
 ANGULAR ----- ± 0°00'

THIRD ANGLE PROJECTION

 REF. No. SCALE
 NONE

DWG NUMBER
 H15464N
 442-MRKTNG

TITLE TO AND OWNERSHIP OF THIS ENGINEERING DATA REMAINS IN Mueller Co. NO USE IS TO BE MADE OF THIS DATA EXCEPT AS SPECIFICALLY AUTHORIZED BY Mueller Co. ASSENT ON THE PART OF THE RECIPIENT TO THESE CONDITIONS IS PRESUMED

REV	ECR	DESCRIPTION	DATE	BY	CHKR
PER EST NO:	DXXXX	EST FIN	WT = 0.0000	lbs	

90° IPS INSTA-TITE LLB SERVICE FITTING
 DWG NUMBER
 H15464N