

| No. | DESCRIPTION | MATERIAL DESCRIPTION |
|-----|--------------|----------------------------------|
| 1 | SPUD | CAST LOW LEAD BRASS ALLOY |
| 2 | PJ GASKET | ASTM D2000 (BUNA N) |
| 3 | WASHER | POLYPROPYLENE |
| 4 | CLPG NUT SUB | CAST BRASS ASTM B62 ALLOY C83600 |

| SIZE | A | B |
|---------|------|------|
| 3/4" | 1.72 | 1.79 |
| 1" | 2.00 | 2.00 |
| 1"x3/4" | 2.00 | 2.00 |
| 1 1/2" | 2.38 | 2.75 |
| 2" | 2.84 | 3.09 |

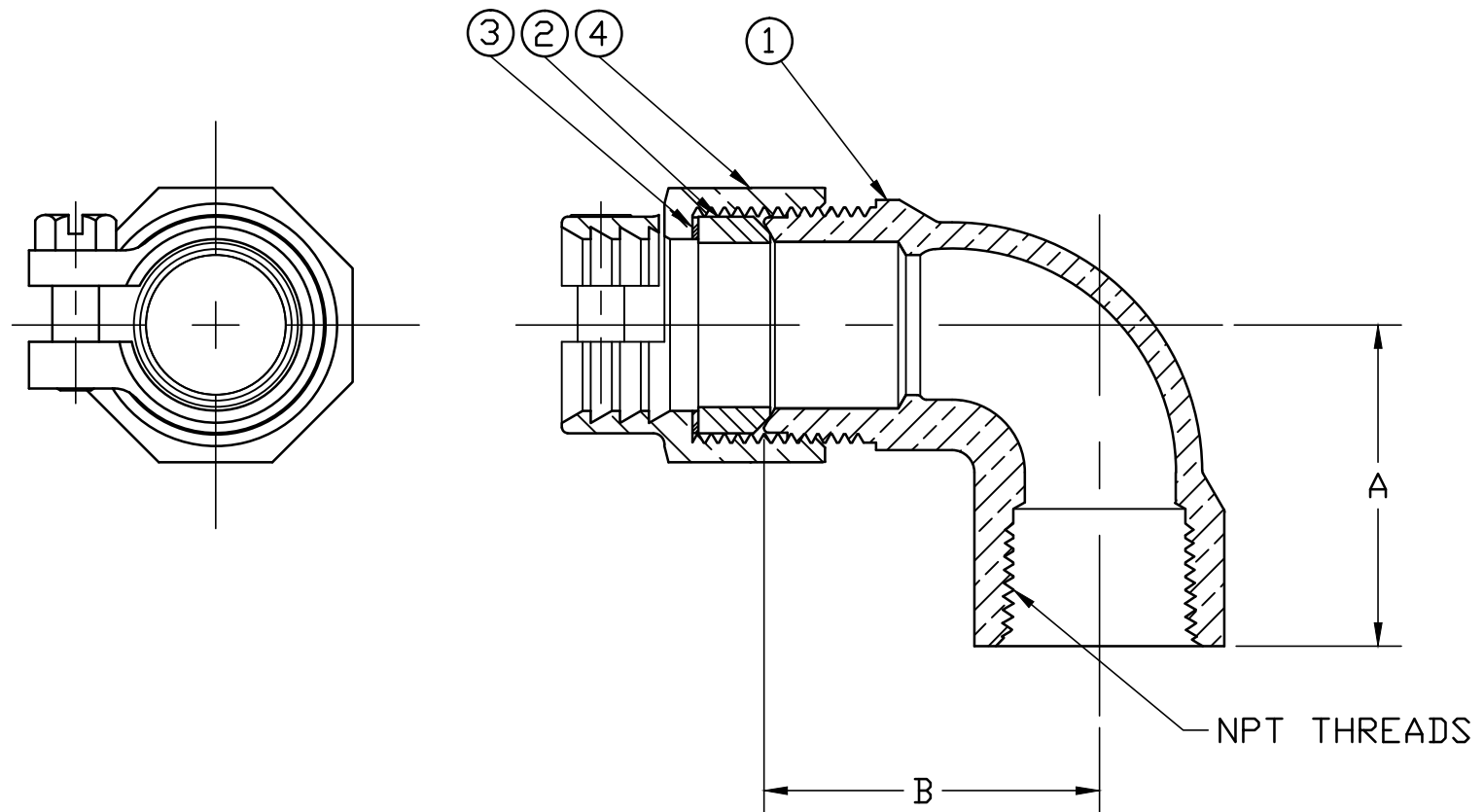

ALL WETTED PARTS ARE LOW LEAD BRASS ALLOY

FILEPATH: PROD-ENG\MUELLER\APPROVED\P15533N

| | | | | | | | | | | |
|--|--|--|--|--|--|-------|-----|---------|---|------------------------|
| | | | | | | DRFTR | RWB | 5/19/16 | Mueller Co. | |
| | | | | | | CHKR | | | | |
| | | | | | | ENGR | | | | |
| | | | | | | MGR | | | | |
| | | | | | | | BY | DATE | UNLESS OTHERWISE NOTED | THIRD ANGLE PROJECTION |
| | | | | | | | | | SURFACE PREPARATION: | |
| | | | | | | | | | BREAK CORNER(S) ---- .000 | |
| | | | | | | | | | SURFACE FINISH --XXX RMS | SCALE |
| | | | | | | | | | TOLERANCE(S): | FULL |
| | | | | | | | | | LINEAR ----- ± .000 | |
| | | | | | | | | | ANGULAR ----- ± 0°00' | |
| | | | | | | | | | MAT'L: DESCR. QUARTER BEND LLB SERVICE FITTING CTS PJ x FIP | |
| | | | | | | | | | | DWG NUMBER P15533N |
| | | | | | | | | | PER EST NO: DXXXX EST FIN WT = 0.0000 lbs | |

DWG NUMBER
P15533N
442-MRKTG

TITLE TO AND OWNERSHIP OF THIS ENGINEERING DATA REMAINS IN Mueller Co. NO USE IS TO BE MADE OF THIS DATA EXCEPT AS SPECIFICALLY AUTHORIZED BY Mueller Co. ASSENT ON THE PART OF THE RECIPIENT TO THESE CONDITIONS IS PRESUMED