

COVER BOLTS/NUTS		
TYPE	MATERIAL	✓
STANDARD	STEEL/ZINC	
S1	304 STN. STEEL	
S3	316 STN. STEEL	

MARKING

SIZE (INCH)
CCNE
200 CWP
AWWA C508
SERIES 8000



SC I
YEAR
POURING DATE

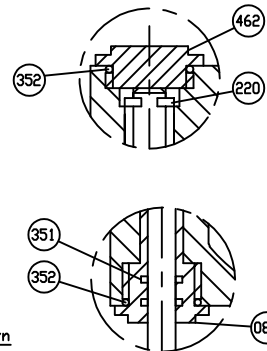
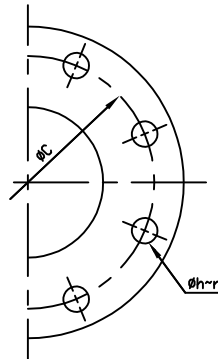
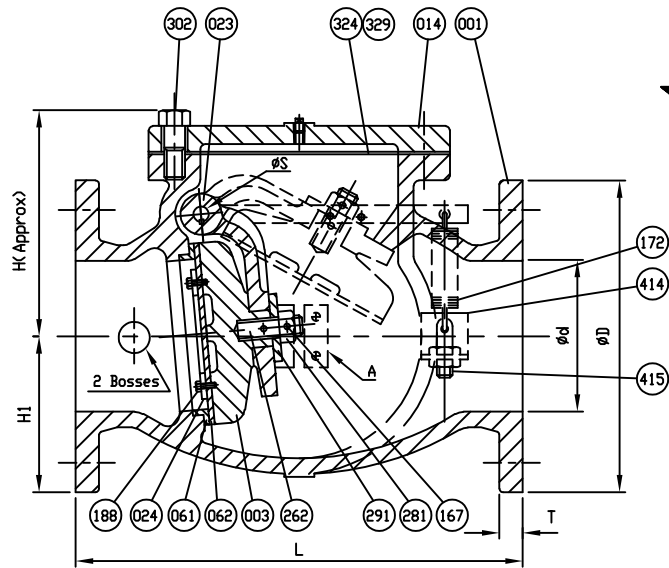

NO.	PARTS	MATERIAL	ASTM. DESIGNATION.	Q'TY
462	Retaining Plug	Brass	B 21	1
415	Stud Nut & Nut	Zinc Coated Steel	A 307 Grade B	1
414	Arm B	Zinc Coated Steel	A 36	1 set
352	O-Ring C	Rubber (Buna N)	D 2000 BK 707	2
351	O-Ring B	Rubber (Buna N)	D 2000 BK 707	2
329	Cover O-Ring	Rubber (Buna N)	D 2000 BK 807	1
324	Cover Gasket	Rubber (Buna N)	D 2000 BK 807	1
302	Cover Bolt	See Cover Bolt Table		1 set
291	Washer	Brass	B 21	1
287	Spacer	Brass	B 21	2
281	Disc Nut	Brass	B 21	1
262	Disc Stud	Brass	B 21	1
220	Snap Ring	Stainless Steel	A 276 Type 420	1
188	Disc Seat Bolt	Stainless Steel	A 276 Type 304	1 set
172	Spring	Zinc Coated Steel	A 36	1
167	Pin	Stainless Steel	A 276 Type 304	2
166	Plug	Stainless Steel	A 276 Type 304	1
161	Key	Stainless Steel	A 276 Type 304	1
159	Hinge Pin	Stainless Steel	A 276 Type 304	1
155	Weight Arm	Ductile Iron	A 536 Gr. 65-45-12	1
154	Bolt & Nut	Zinc Coated Steel	A 307 Grade B	2
153	Bolt	Zinc Coated Steel	A 307 Grade B	1
088	Seat Nut	Brass	B 21	1
062	Disc Seat Ring	Rubber (Buna N)	D 2000 BK 807	1
061	Body Seat Ring	Bronze	B 62	1
024	Seat Holder	See Remark		1
023	Arm	Ductile Iron	A 536 Gr. 65-45-12	1
014	Cover	Cast Iron	A 126 Class B	1
003	Disc	Cast Iron	A 126 Class B	1
001	Body	Cast Iron	A 126 Class B	1

MATERIAL LIST		
HYDRO SHELL		400 PSI.
HYDRO VALVE SEAT		200 PSI.
HYDRO BACK SEAT		— PSI.
AIR SEAT		— PSI.
STEAM		— PSI.
TEST PRESSURE		
WORKING PRESSURE		200 PSI.



SCALE	DR. JON COLPAN	DATE 10/20/10	REF. DWG.
N.T.S.	CHK.	APP.	E.C.N. USA1646C
TITLE			
SIZE 2" TO 12" SWING CHECK VALVE AWWA C508 BRONZE BODY SEAT RING & BUNA N DISC SEAT RING WITH ONE LEVER AND SPRING			
TYPE:	A2602-6B1LS	DWG NO.	M80003
		REV.	5

SIZE		L	ANSI B16.1 CL. 125					ØS	H	H1	I	J	K	M	N	Ø	P	L1	PLUG SIZE
in.	mm.		ØD	ØC	Øh	n	T												
2	(50)	8	6	4 3/4	3/4	4	5/8	3/8	4 15/16	3	7/16	7/8	1 1/16	—	5/16x18v<UNC>	—	3/8	2 13/16	1/2
2 1/2	(65)	8 1/2	7	5 1/2	3/4	4	11/16	3/8	5 11/16	3 1/2	7/16	7/8	1 1/16	—	5/16x18v<UNC>	—	3/8	3 9/16	1/2
3	(80)	9 1/2	7 1/2	6	3/4	4	3/4	1/2	6 1/16	3 3/4	3/4	1 1/2	3	2 1/2	1/2x13v<UNC>	4	3/4	4 1/16	1/2
4	(100)	11 1/2	9	7 1/2	3/4	8	15/16	1/2	6 7/8	4 1/2	3/4	1 1/2	3	2 1/2	1/2x13v<UNC>	4	3/4	4 15/16	1/2
6	(150)	14	11	9 1/2	7/8	8	1	3/4	8 1/2	5 1/2	3/4	1 1/2	3	2 1/2	1/2x13v<UNC>	4	3/4	5 15/16	3/4
8	(200)	19 1/2	13 1/2	11 3/4	7/8	8	1 1/8	7/8	9 15/16	6 3/4	7/8	1 3/4	3 1/2	3 1/4	5/8x11v<UNC>	5	1 1/4	8 1/16	3/4
10	(250)	24 1/2	16	14 1/4	1	12	1 3/16	1	11 3/16	8	7/8	1 3/4	3 1/2	3 1/4	5/8x11v<UNC>	5	1 1/4	9 3/16	1
12	(300)	27 1/2	19	17	1	12	1 1/4	1 1/8	13 3/16	9 1/2	7/8	1 3/4	3 1/2	3 1/4	5/8x11v<UNC>	5	1 1/4	10 13/16	1

REV. 1: CHANGED ITEM 166 MTRL. TYPE FROM MALLEABLE IRON A47 TO, UJC, 03/08/11, ECR# 456
REV. 2: ADDED 329, DJK, 6/20/18
REV. 3: ADDED COVER BOLT TABLE, RAL, 10/22/18
REV. 4: ADDED PLUG SIZE COLUMN, TT/JL, 06/12/19
REV. 5: UPDATED NEW LOGOS, TT/JL, 06/12/19

DS01 ISSUED - 240640 REVISED -