

K-NO & SIZE HOLES EQUALLY SPACED ON L-DIA BOLT CIRCLE EACH END

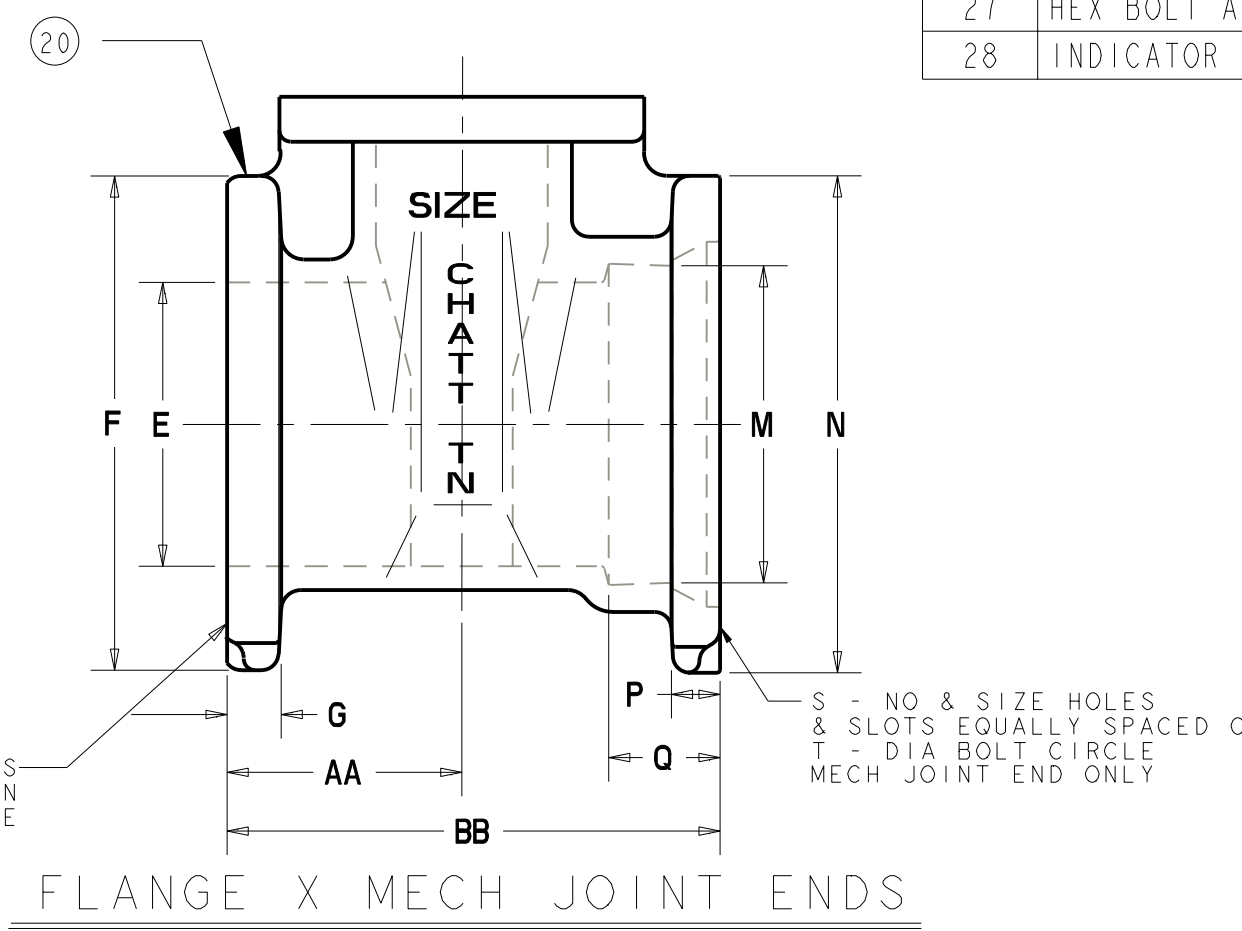

K-NO & SIZE HOLES EQUALLY SPACED ON L-DIA BOLT CIRCLE FLANGE END ONLY

S-NO & SIZE HOLES & SLOTS EQUALLY SPACED ON T-DIA BOLT CIRCLE MECH JOINT END ONLY

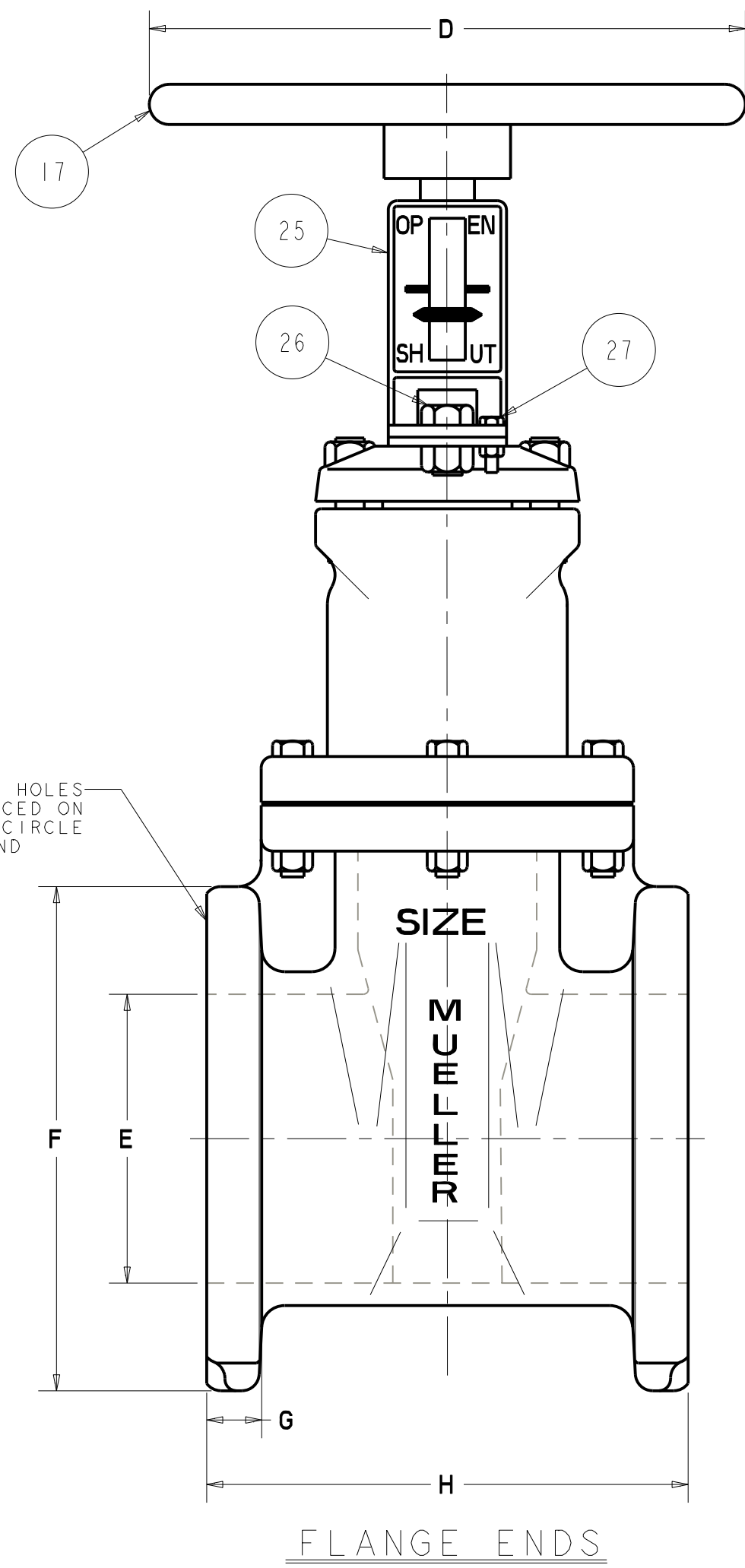
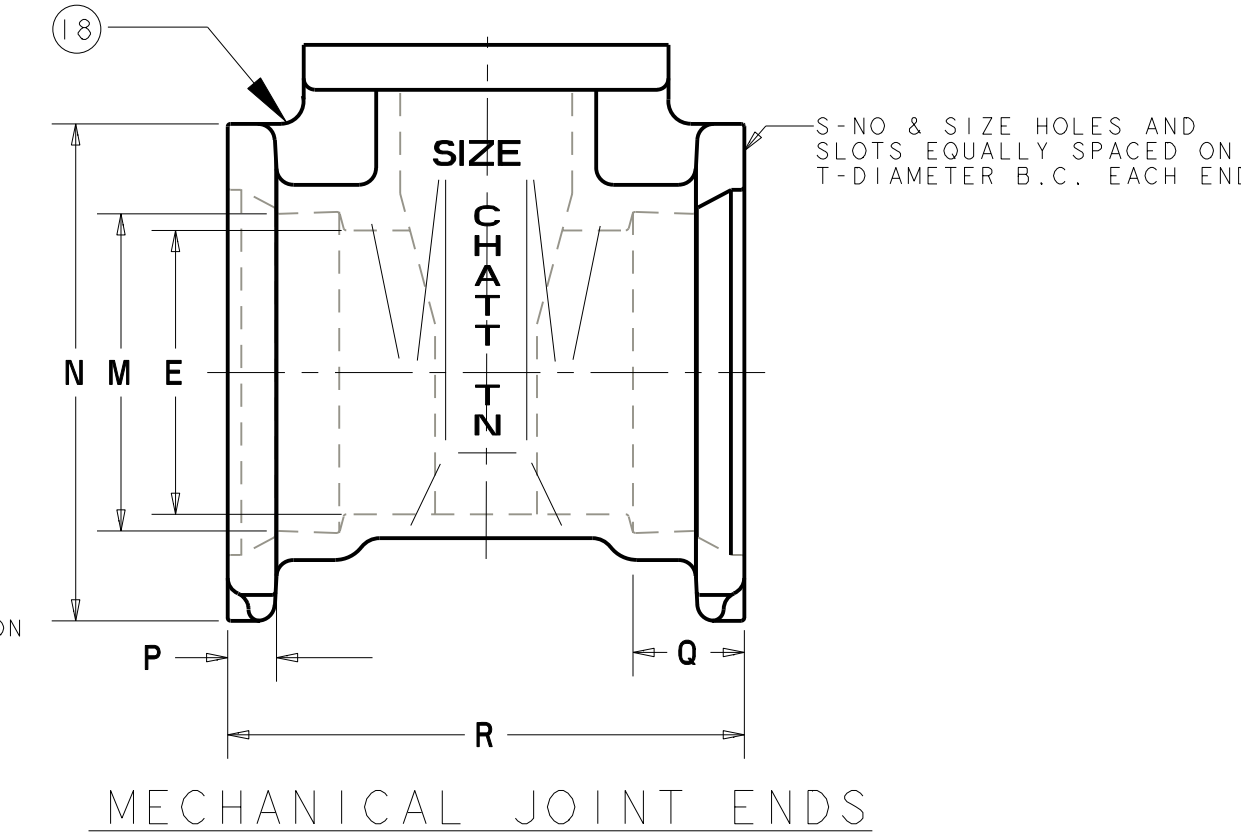

S-NO & SIZE HOLES AND SLOTS EQUALLY SPACED ON T-DIAMETER B.C. EACH END

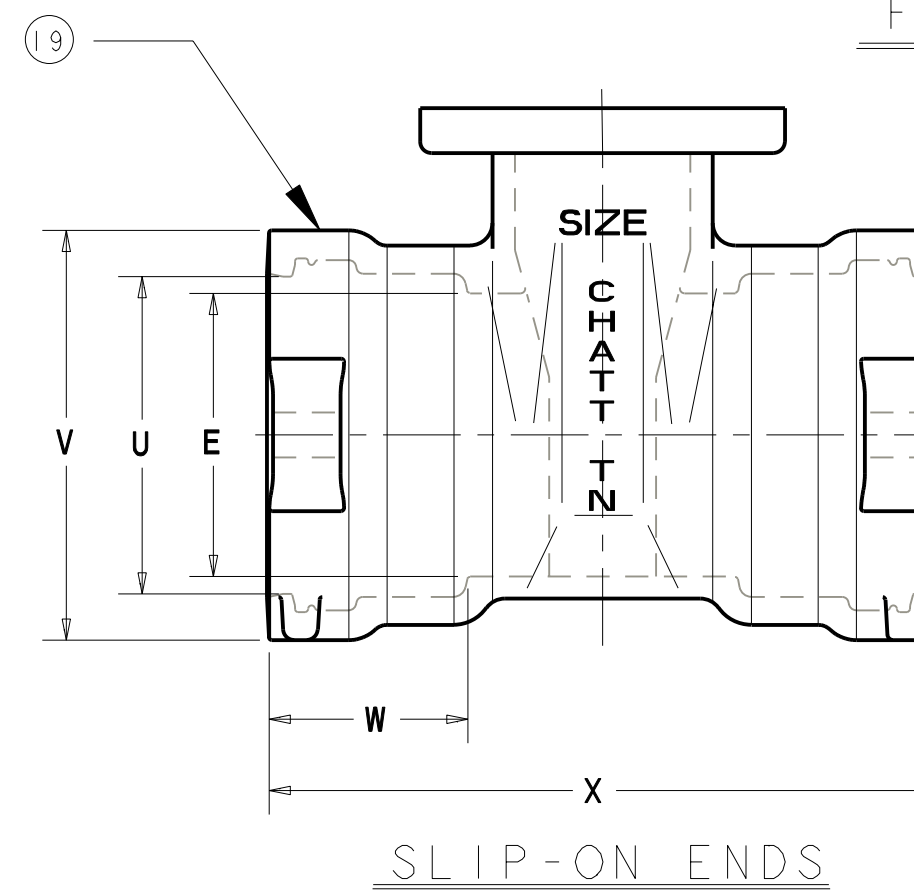

Y - DISTANCE BETWEEN STRAPPING LUG HOLES ACROSS FACE OF VALVE END EACH END

K - NO & SIZE HOLES EQUALLY SPACED ON L - DIA BOLT CIRCLE FLANGE END ONLY

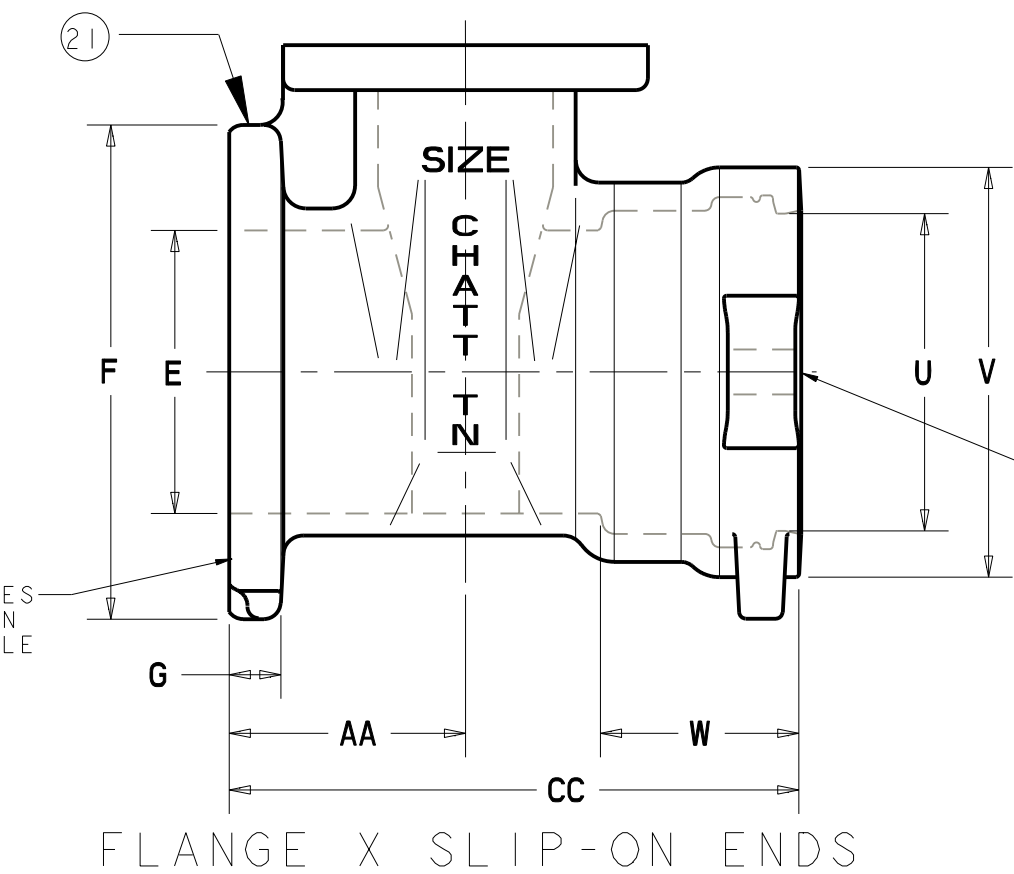

Y - DISTANCE BETWEEN STRAPPING LUG HOLES ACROSS FACE OF VALVE END SLIP-ON END ONLY

FLANGE X SLIP-ON ENDS

PART LIST				
ITEM	DESCRIPTION	REQ'D	MATERIAL	ASTM
1	CAP SCREW	1	304 STAINLESS STEEL	A193 GRADE B8
2	WRENCH NUT	1	CAST IRON [SEE NOTE 2]	A126 CLASS B
3	STEM	1	BRONZE	B138 ALLOY C67600
4	STUFFING BOX	1	CAST IRON [SEE NOTE 2]	A126 CLASS B
5	STUFFING BOX BOLTS STUFFING BOX NUTS	2	304 STAINLESS STEEL 304 STAINLESS STEEL	A193 GRADE B8 F594 GROUP 1
6	O-RING	3	RUBBER	D2000 NITRILE
7	O-RING	1	RUBBER	D2000 NITRILE
8	ANTI-FRICTION WASHER	2	CELCON	
9	BONNET	1	CAST IRON [SEE NOTE 2]	A126 CLASS B
10	BONNET BOLTS BONNET NUTS	"Z"	304 STAINLESS STEEL 304 STAINLESS STEEL	A193 GRADE B8 F594 GROUP 1
11	BONNET GASKET (O-RING)	1	RUBBER	D2000 NITRILE
13	DISC NUT	1	BRONZE	B62 ALLOY C83600
14	DISC	1	SEE NOTES 1 & 2	
15	GUIDE CAP	2	CELCON	M90
16	BODY - FLANGE ENDS	1	CAST IRON [SEE NOTE 2]	A126 CLASS B
17	HANDWHEEL	1	CAST IRON [SEE NOTE 2]	A126 CLASS B
18	BODY - MJ ENDS	1	CAST IRON [SEE NOTE 2]	A126 CLASS B
19	BODY - SLIP-ON ENDS	1	CAST IRON [SEE NOTE 2]	A126 CLASS B
20	BODY - FLANGE x MJ END	1	CAST IRON [SEE NOTE 2]	A126 CLASS B
21	BODY - FLANGE x SLIP-ON END	1	CAST IRON [SEE NOTE 2]	A126 CLASS B
22	WIPER RING	1	RUBBER	
23	INDICATOR PLATE BRACKET	1	STAINLESS STEEL	A276 TYPE 304L
24	CAP SCREW	1	STEEL	A307 GR B,ZN PLTD
25	INDICATOR PLATE	1	BRONZE	B62
26	HEX BOLT AND NUT	1	STEEL	A307 GR B,ZN PLTD
27	HEX BOLT AND NUT	1	STEEL	A307 GR B,ZN PLTD
28	INDICATOR POINTER	1	BRONZE	B62

DIMENSIONS FOR RESILIENT WEDGE VALVE - INCHES (this drawing only)

VALVE SIZE	A	B	C	D	E	F	G	H	K	L	M	N	P	Q	R	S	T	U	V	W	X	Y	Z	AA	BB	CC	TURN TO OPEN
4	18.94	8.25	10.79	11.00	4.30	9.00	0.94	9.00	8 - 0.75	7.50	4.90	9.12	1.00	2.50	10.00	4 - 0.88	7.50	4.92	6.88	4.12	12.81	8.62	4	4.50	9.50	10.91	14
6	23.13	10.50	13.50	13.00	6.30	11.00	1.06	10.50	8 - 0.88	9.50	7.00	11.12	1.09	2.50	11.60	6 - 0.88	9.50	7.02	9.12	4.38	14.96	10.62	6	5.25	11.06	12.73	20.5
8	27.31	13.21	16.36	14.00	8.30	13.50	1.19	11.50	8 - 0.88	11.75	9.15	13.37	1.18	2.50	12.68	6 - 0.88	11.75	9.30	11.38	5.62	17.94	13.12	6	5.75	12.09	14.72	26.5
10	31.38	16.48	19.99	16.00	10.30	16.00	1.25	13.00	12 - 1.00	14.25	11.20	15.62	1.25	2.50	14.88	8 - 0.88	14.00	11.38	13.50	5.62	18.50	16.38	8	6.50	13.94	15.75	33
12	34.62	16.83	21.00	16.00	12.30	19.00	1.31	14.00	12 - 1.00	17.00	13.30	17.88	1.31	2.50	15.00	8 - 0.88	16.25	13.33	15.75	5.62	18.70	18.12	8	7.00	14.50	16.35	38.5

NOTES:
 1. RUBBER ENCAPSULATED CAST IRON DISC
 CAST IRON - ASTM A126 CLASS B
 RUBBER - SBR - ASTM D2000
 2. MANUFACTURER'S OPTION TO UPGRADE MAT'L TO DI - A536 GR 65-45-12

SR BY: MCB	10/30/08	UNLESS OTHERWISE NOTED	THIRD ANGLE PROJECTION	C.D. NO.
CHKD: NAF	10/30/08	BREAK CAST CORNERS!		PART. NO.
ENGR: JWR	10/30/08	BREAK MACH CORNERS!		
MFG:		TOLERANCES	PURCH. NO.	FINISH
TOOL:		UNLESS OTHERWISE NOTED	REF. NO.	SCALE
DRY:		LINEAR ±	ANGULAR ±	NONE
MAT'L NOTED			STR. NO.	

MAT'L: NOTED	DESCR: 4-121N RWG A2360 W/ SLOT & NEEDLE POSITION INDICATOR	NUMBER: 6816
--------------	---	--------------

APPROVED
 By Jason W. Bradley at 1:56 pm, Nov 06, 2008