

6886 4"-12" NRS A2360 RWGV WITH SPUR GEAR W/316 SS FASTENERS W/EVERDUR STEM

ITEM	DESCRIPTION	REQ'D	MATERIAL	ASTM	
1	SPUR GEAR (SEE NOTE 3)	1	CAST IRON		
2	WRENCH/OP NUT	1	CAST IRON [SEE NOTE 2]	A126	CLASS B
3	KEY	1	STEEL		
4	HANDWHEEL	1	STEEL		OPTIONAL
6	GEAR STEM NUT	1	STEEL		
7	O-RING	1	RUBBER	D2000	
8	GEAR GASKET	1	RUBBER	D2000	
9	ADAPTER	1	CAST IRON [SEE NOTE 2]	A126	CLASS B
10	STUFFING BOX	1	CAST IRON [SEE NOTE 2]	A126	CLASS B
11	BONNET	1	CAST IRON [SEE NOTE 2]	A126	CLASS B
12	BODY	1	CAST IRON [SEE NOTE 2]	A126	CLASS B
13	BONNET BOLT	"P"	316 STAINLESS STEEL	A193	GROUP B8M
14	BONNET BOLT NUT	"P"	316 STAINLESS STEEL	A194	GROUP 8M
15	KEY	1	STEEL		
16	CAP SCREW	4	316 STAINLESS STEEL	A193	GROUP B8M
17	ADAPTER BOLT	2	316 STAINLESS STEEL	A193	GROUP B8M
18	ADAPTER BOLT NUT	2	316 STAINLESS STEEL	A194	GROUP 8M
19	ADAPTER O-RING	1	RUBBER	D2000	
20	STUFFING BOX BOLT	2	316 STAINLESS STEEL	A193	GROUP B8M
21	STUFFING BOX BOLT NUT	2	316 STAINLESS STEEL	A194	GROUP 8M
22	STEM O-RINGS	3	RUBBER	D2000	
23	STUFFING BOX O-RING	1	RUBBER	D2000	
24	ANTI FRICTION WASHER	2	CELCON		M-90
25	STEM	1	BRONZE	B98	66100 OR 65500
26	BONNET BODY O-RING	1	RUBBER		
27	DISC NUT	1	BRONZE	B62	ALLOY C83600
28	DISC	1	SEE NOTES 1 & 2		
29	GUIDE CAP	2	CELCON		M-90
30	SET SCREW	1	STEEL		

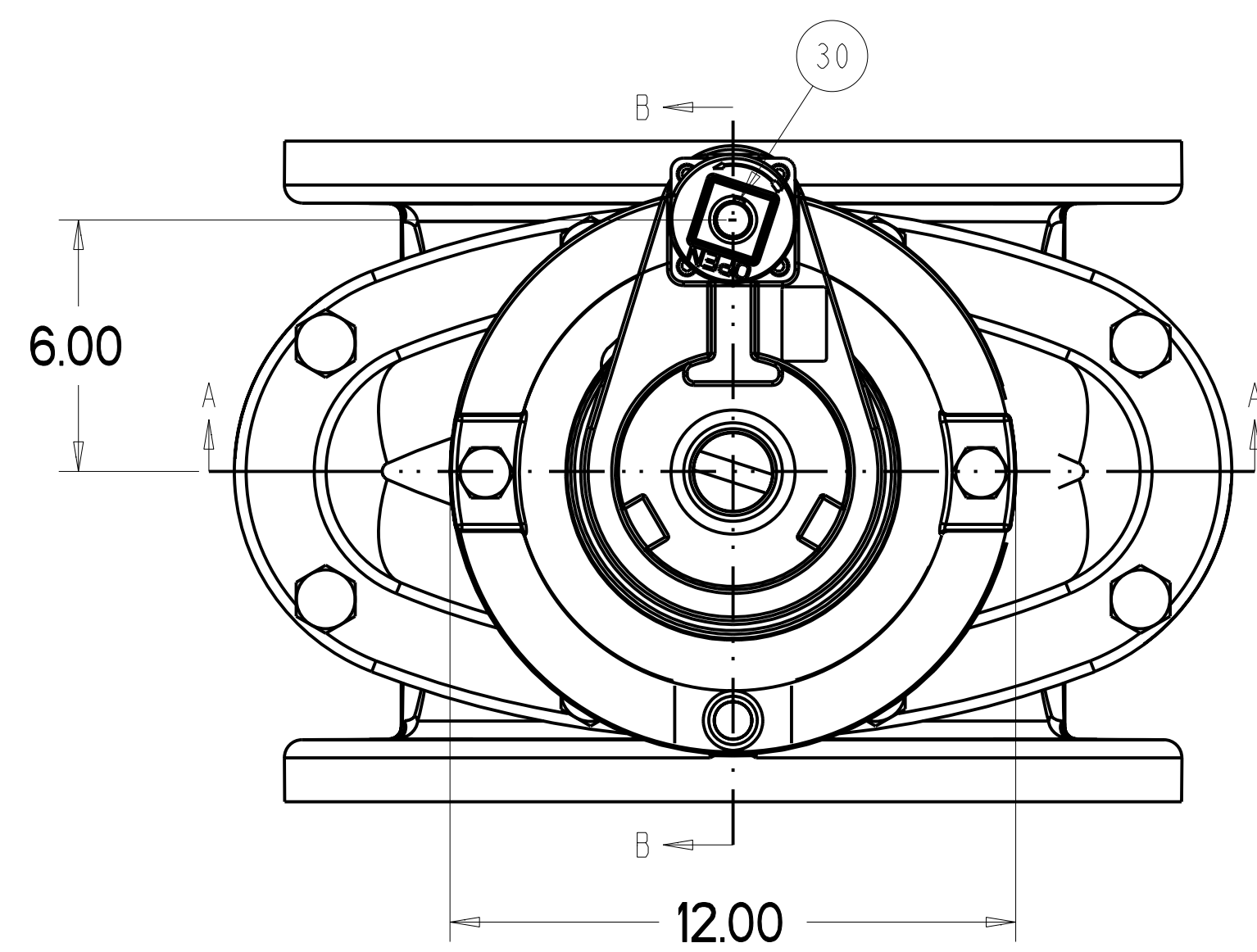
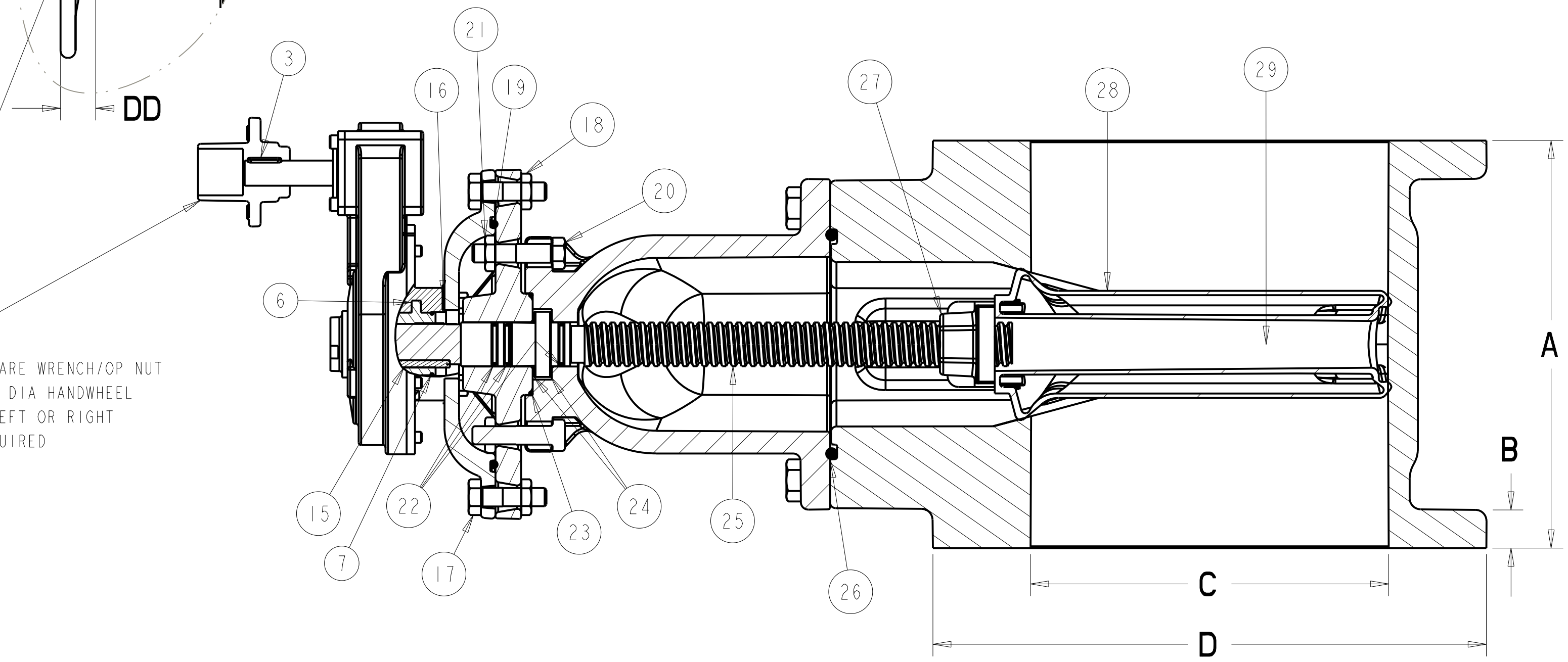
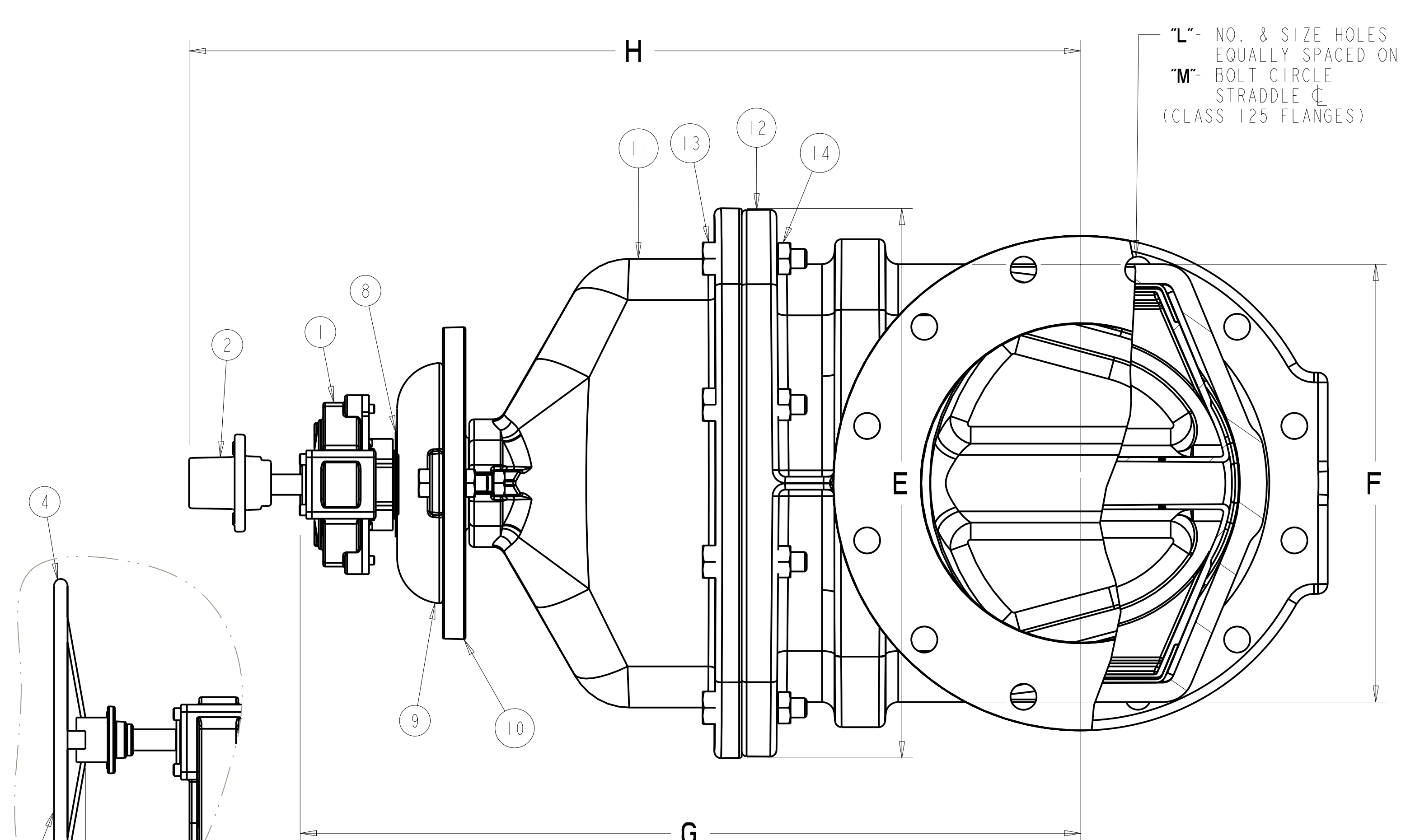

"2" SQUARE WRENCH/OP NUT OR "J" DIA HANDWHEEL OPEN LEFT OR RIGHT AS REQUIRED

"L" - NO. & SIZE HOLES EQUALLY SPACED ON  
 "M" - BOLT CIRCLE STRADDLE C (CLASS 125 FLANGES)

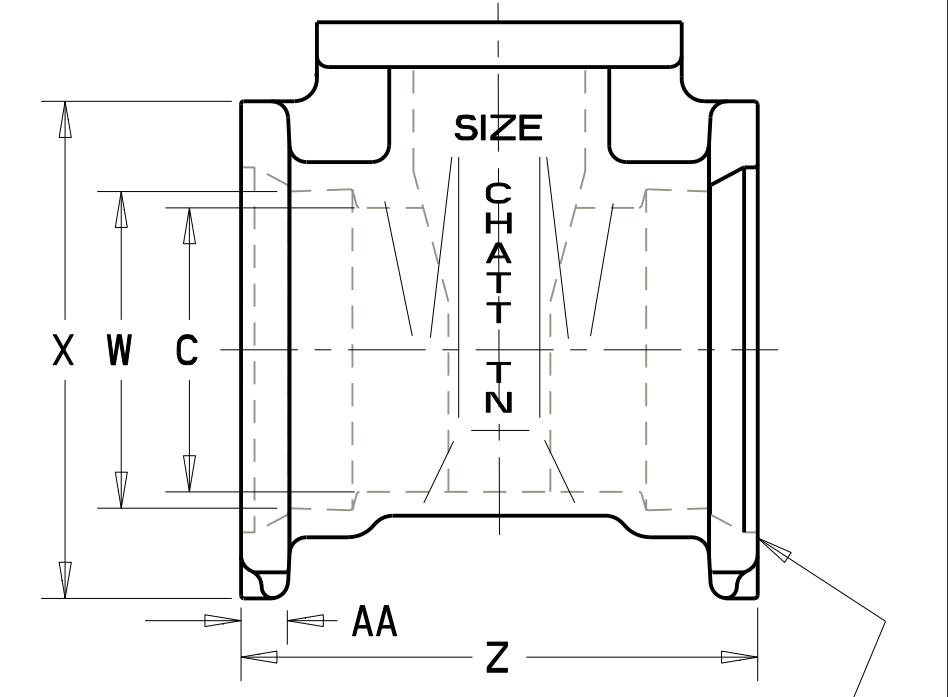
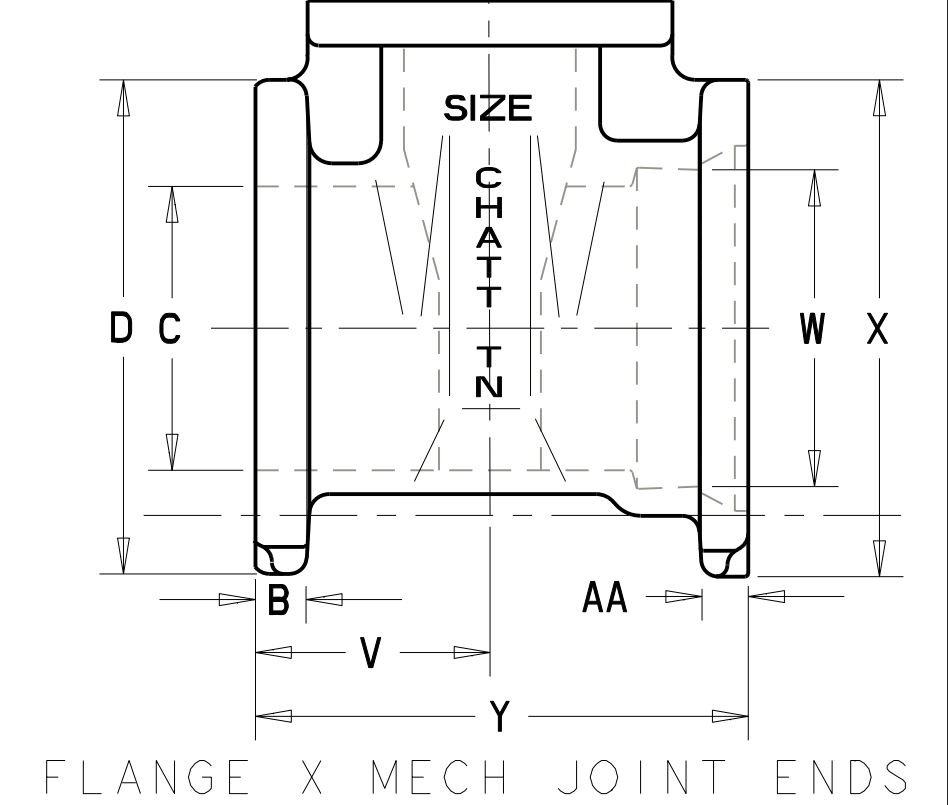
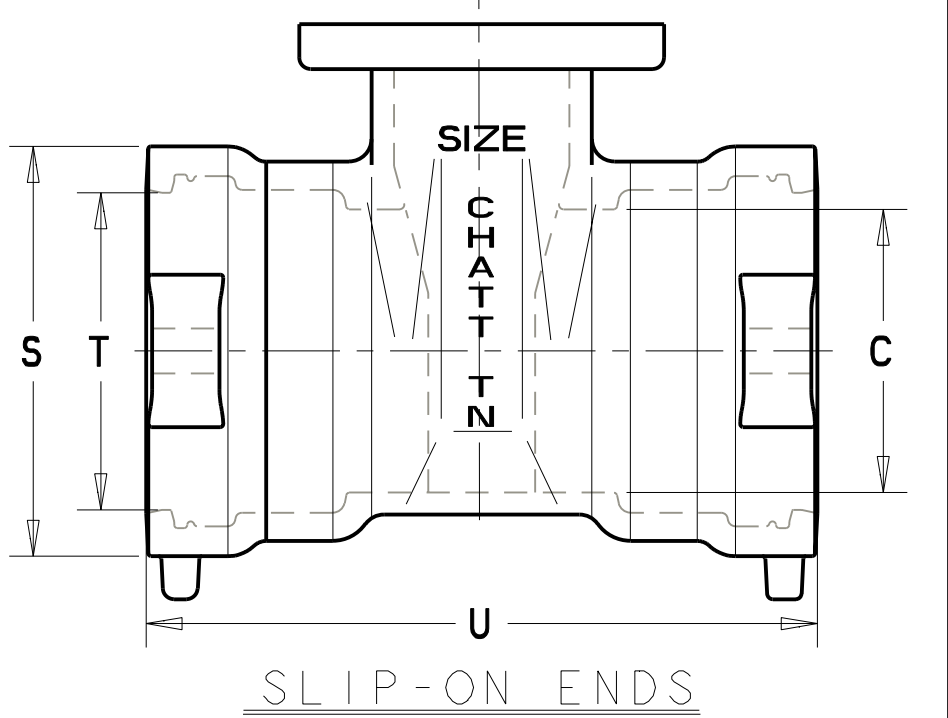
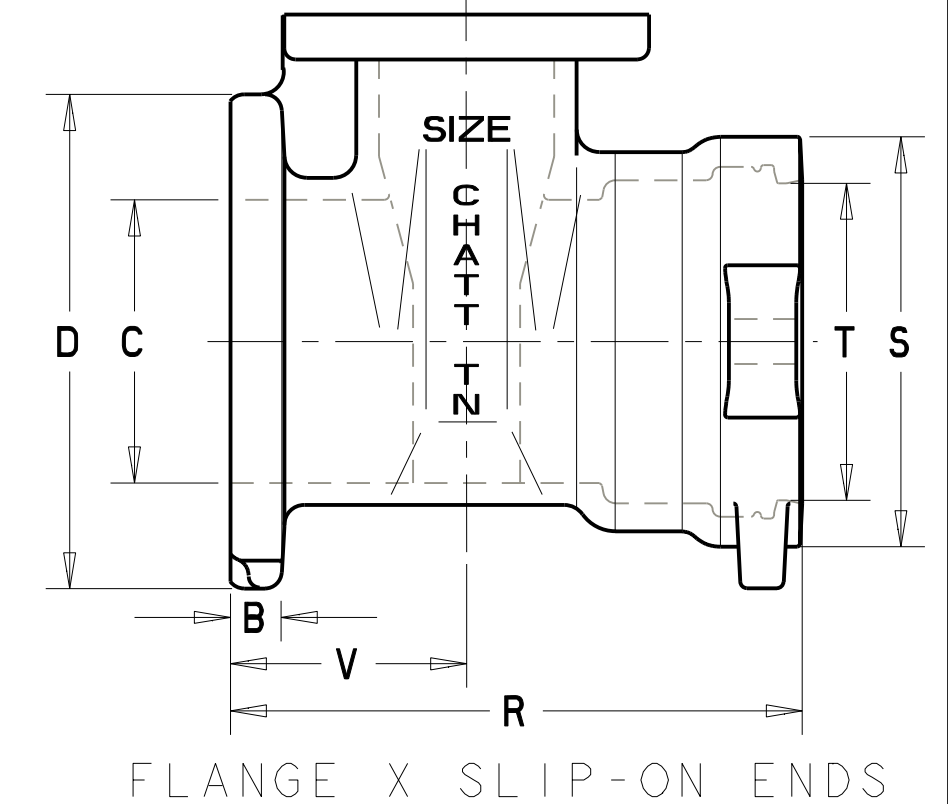

"BB" - NO & SIZE HOLES & SLOTS EQUALLY SPACED ON  
 "CC" - DIA BOLT CIRCLE EACH END

SIZE	A	B	C	D	E	F	G	H	J	L	M	P	R	S	T	U	V	W	X	Y	Z	AA	BB	CC	DD	URNS TO OPEN ROTORK RATIO 2:1
4	9.00	0.94	4.30	9.00	10.79	8.25	16.71	23.13	12.00	8 - 0.75	7.50	4	10.91	6.88	4.92	12.81	4.50	4.90	9.12	9.50	10.00	1.00	4 - 0.88	7.50	1.85	28
6	10.50	1.06	6.30	11.00	13.50	10.50	20.43	26.85	12.00	8 - .880	9.50	6	12.73	9.12	7.02	14.96	5.25	7.00	11.12	11.06	11.60	1.09	6 - 0.88	9.50	1.85	41
8	11.50	1.19	8.30	13.50	16.36	13.21	23.83	30.25	12.00	8 - .880	11.75	6	14.72	11.38	9.30	17.94	5.75	9.15	13.37	12.09	12.68	1.18	6 - 0.88	11.75	1.85	53
10	13.00	1.25	10.30	16.00	19.99	16.48	25.47	31.89	18.00	12 - 1.00	14.25	8	15.75	13.50	11.38	18.50	6.50	11.20	15.62	13.94	14.88	1.25	8 - 0.88	14.00	1.85	66
12	14.00	1.31	12.30	19.00	21.00	16.83	30.16	36.58	18.00	12 - 1.00	17.00	8	16.35	15.75	13.33	18.70	7.00	13.30	17.88	14.50	15.00	1.31	8 - 0.88	16.25	1.85	77

- NOTES:  
 1. RUBBER ENCAPSULATED CAST IRON DISC  
 CAST IRON - ASTM A126 CLASS B  
 RUBBER - SBR - ASTM D2000  
 2. MANUFACTURER'S OPTION TO UPGRADE  
 MAT'L TO DI - A536 GR 65-45-12  
 3. VALVES WILL BE FURNISHED WITH  
 ROTORK IS-2 OPERATORS.

SR BY	JAB	12/20/10	UNLESS OTHERWISE NOTED	THIRD ANGLE PROJECTION	C.D. NO.
CHKD	CGH	12/20/10	BREAK CAST CORNERS!		PART. NO.
ENGR	RWV	12/20/10	BREAK MACH CORNERS!		
MFR			TOLERANCES	PURCH. N/A	FINISH ASSY
INS			UNLESS OTHERWISE NOTED	REF. NO.	SCALE NONE
TOOL			LINEAR	ANGULAR	STR. NO.
FBY			±	±	
MAT'L	SEE TABLE				

**APPROVED**  
 By Charles Hines at 2:01 pm, Mar 07, 2011

**Mueller Co.** 4"-12" NRS A2360 RWGV WITH SPUR GEAR W/316 SS FASTENERS W/EVERDUR STEM NUMBER 6886