

K - NO & SIZE HOLES EQUALLY SPACED ON L - DIA BOLT CIRCLE EACH END

K - NO & SIZE HOLES EQUALLY SPACED ON L - DIA BOLT CIRCLE FLANGE END ONLY

S - NO & SIZE HOLES & SLOTS EQUALLY SPACED ON T - DIA BOLT CIRCLE MECH JOINT END ONLY

S - NO & SIZE HOLES & SLOTS EQUALLY SPACED ON T - DIA BOLT CIRCLE EACH END

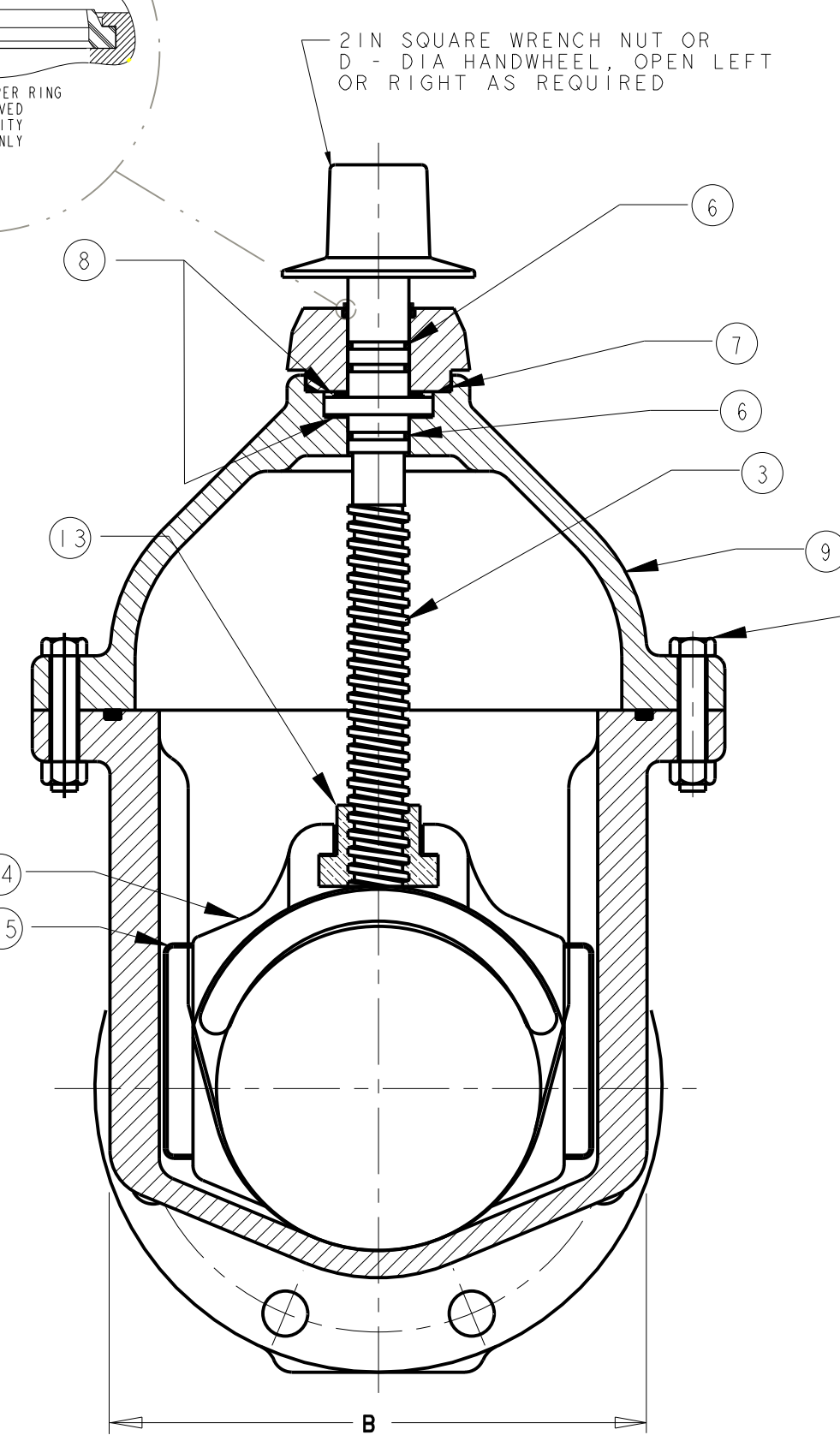
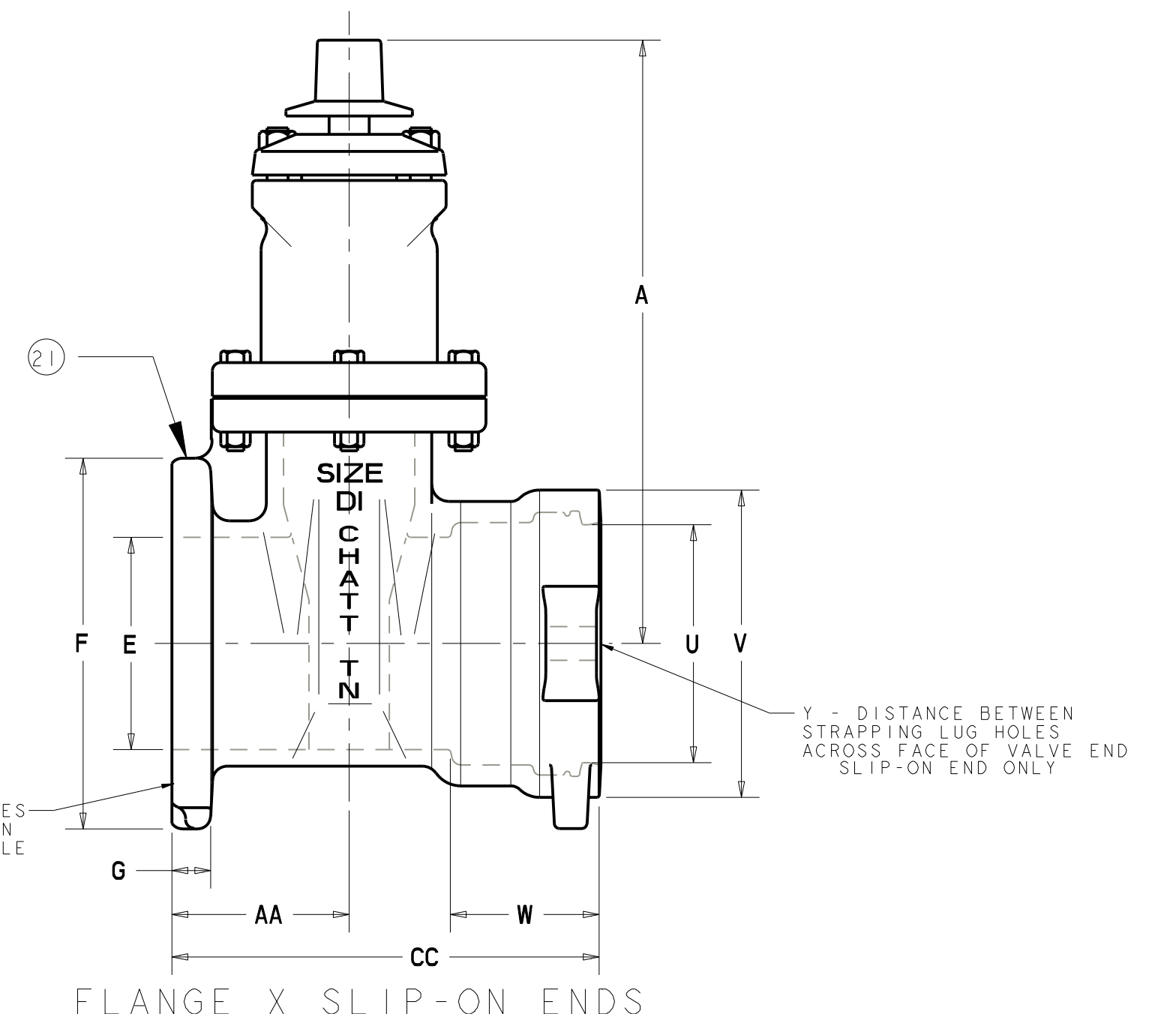
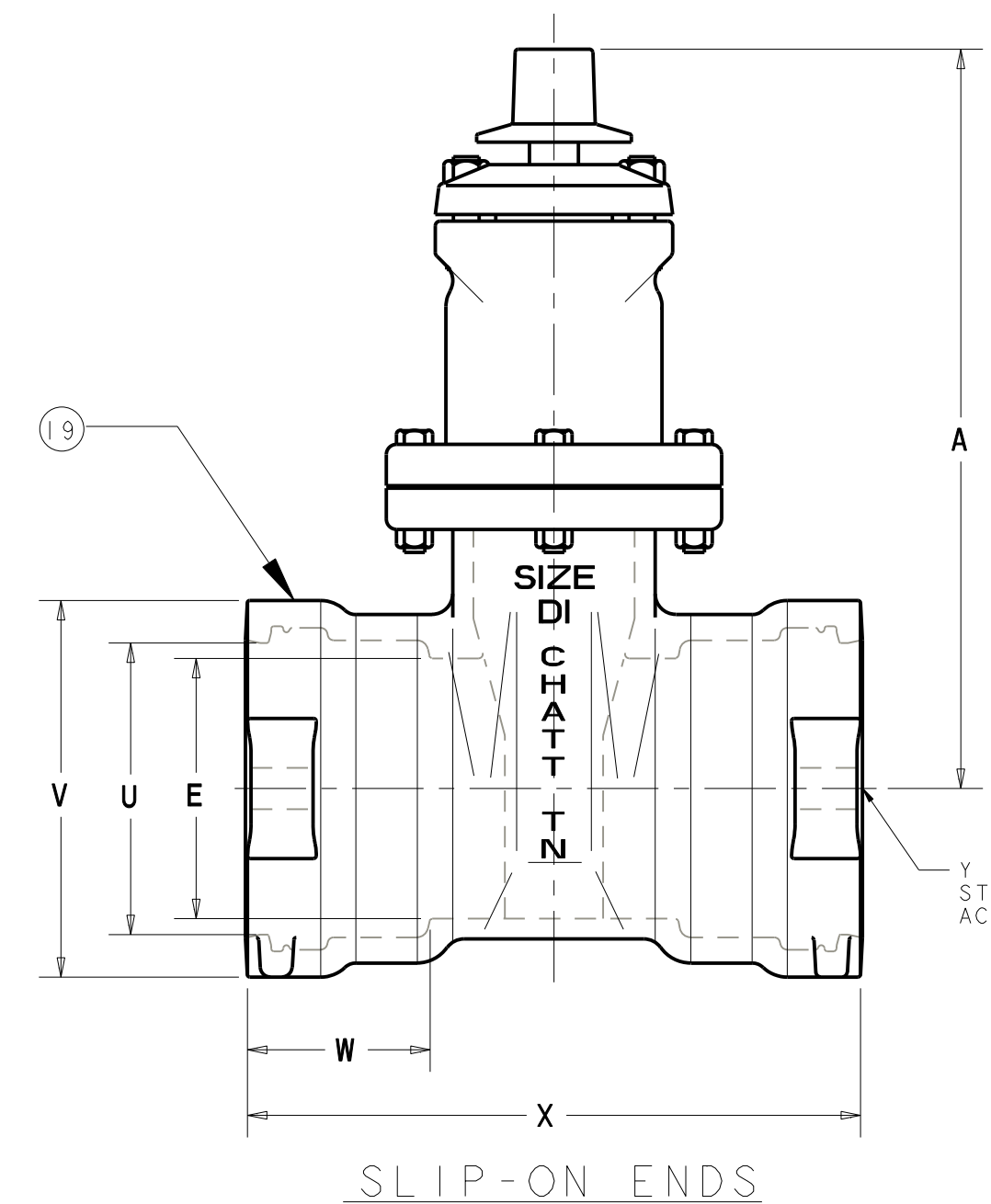
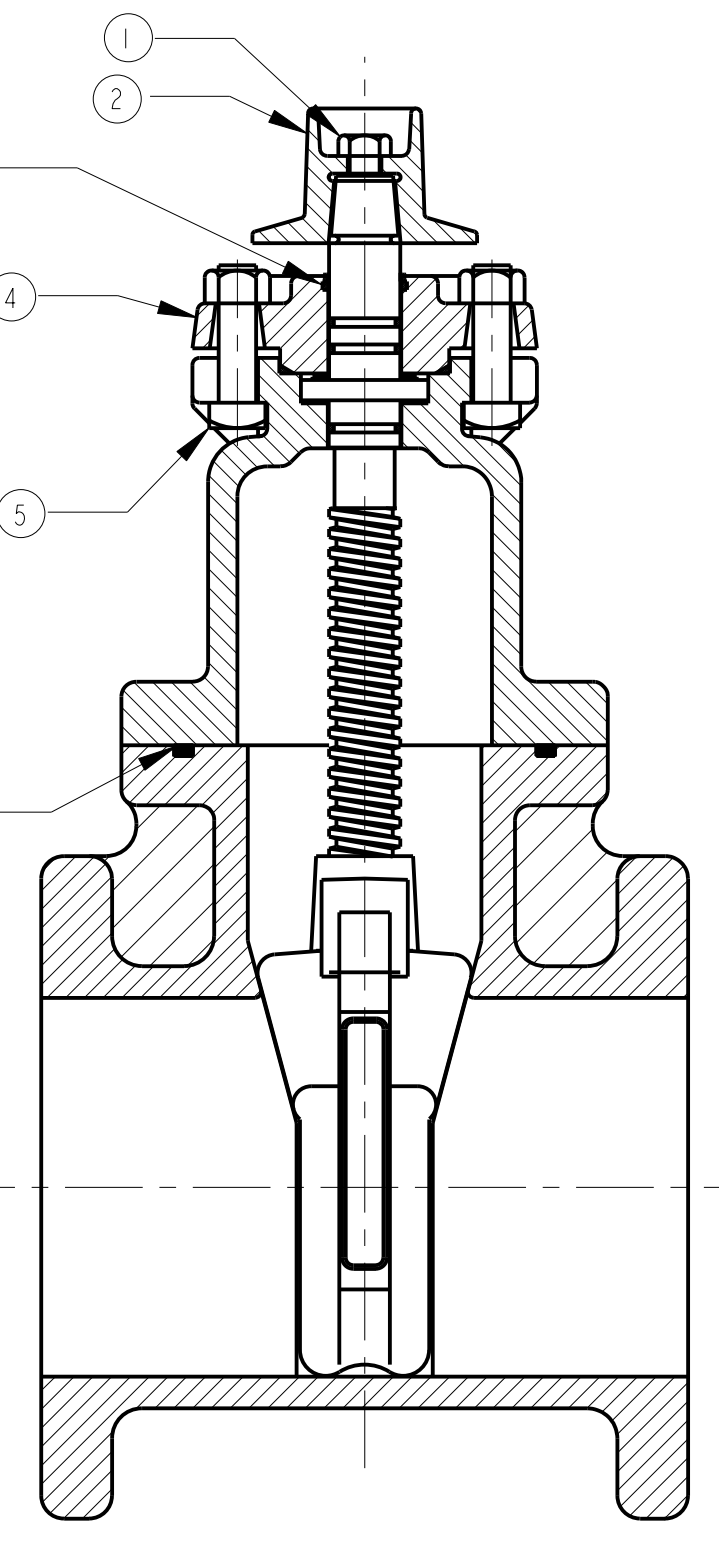

NOTES:  
1. RUBBER ENCAPSULATED CAST IRON DISC  
CAST IRON - ASTM A126 CLASS B  
RUBBER - SBR - ASTM D2000  
2. MANUFACTURER'S OPTION TO UPGRADE MAT'L TO D1 - A536 GR 65-45-12

PART LIST					
ITEM	DESCRIPTION	REQ'D	MATERIAL	ASTM	
1	CAP SCREW	1	316 STAINLESS STEEL	A193	GRADE B8
2	WRENCH NUT	1	CAST IRON [SEE NOTE 2]	A126	CLASS B
3	STEM	1	BRONZE (EVERDUR)	B98	66100 or 65500
4	STUFFING BOX	1	CAST IRON [SEE NOTE 2]	A126	CLASS B
5	STUFFING BOX BOLTS	2	316 STAINLESS STEEL	A193	GROUP B8
	STUFFING BOX NUTS		316 STAINLESS STEEL	A194	GROUP B8
6	O-RING	3	RUBBER	D2000	R34 (SBR)
7	O-RING	1	RUBBER	D2000	R34 (SBR)
8	ANTI-FRICTION WASHER	2	CELCON		
9	BONNET	1	CAST IRON [SEE NOTE 2]	A126	CLASS B
10	BONNET BOLTS	"Z"	316 STAINLESS STEEL	A193	GROUP B8
	BONNET NUTS		316 STAINLESS STEEL	A194	GROUP B8
11	BONNET GASKET (O-RING)	1	RUBBER	D2000	R34 (SBR)
13	DISC NUT	1	BRONZE	B62	ALLOY C83600
14	DISC	1	SEE NOTE 1 & 2		
15	GUIDE CAP	2	CELCON		
16	BODY - FLANGE ENDS	1	CAST IRON [SEE NOTE 2]	A126	CLASS B
17	HANDWHEEL	1	CAST IRON [SEE NOTE 2]	A126	CLASS B
18	BODY - MJ ENDS	1	CAST IRON [SEE NOTE 2]	A126	CLASS B
19	BODY - SLIP-ON ENDS	1	CAST IRON [SEE NOTE 2]	A126	CLASS B
20	BODY - FLANGE x MJ END	1	CAST IRON [SEE NOTE 2]	A126	CLASS B
21	BODY - FLANGE x SLIP-ON END	1	CAST IRON [SEE NOTE 2]	A126	CLASS B
22	WIPER RING	1	RUBBER		

41N - 12IN RWGV A2360 - W/EVERDUR STEM W/316 SS FASTENERS

DIMENSIONS FOR RESILIENT WEDGE VALVE - INCHES (this drawing only)																											
VALVE SIZE	A	B	C	D	E	F	G	H	K	L	M	N	P	Q	R	S	T	U	V	W	X	Y	Z	AA	BB	CC	TURN TO OPEN
4	14.19	8.25	10.79	11.00	4.30	9.00	0.94	9.00	8 - 0.75	7.50	4.90	9.12	1.00	2.50	10.00	4 - 0.88	7.50	4.92	6.88	4.12	12.81	8.62	4	4.50	9.50	10.91	14
6	18.00	10.50	13.50	13.00	6.30	11.00	1.06	10.50	8 - 0.88	9.50	7.00	11.12	1.09	2.50	11.60	6 - 0.88	9.50	7.02	9.12	4.38	14.96	10.62	6	5.25	11.06	12.73	20.5
8	21.50	13.21	16.36	14.00	8.30	13.50	1.19	11.50	8 - 0.88	11.75	9.15	13.37	1.18	2.50	12.68	6 - 0.88	11.75	9.30	11.38	5.62	17.94	13.12	6	5.75	12.09	14.72	26.5
10	25.50	16.48	19.99	16.00	10.30	16.00	1.25	13.00	12 - 1.00	14.25	11.20	15.62	1.25	2.50	14.88	8 - 0.88	14.00	11.38	13.50	5.62	18.50	16.38	8	6.50	13.94	15.75	33
12	28.62	16.83	21.00	16.00	12.30	19.00	1.31	14.00	12 - 1.00	17.00	13.30	17.88	1.31	2.50	15.00	8 - 0.88	16.25	13.33	15.75	5.62	18.70	18.12	8	7.00	14.50	16.35	38.5

**APPROVED**  
By Nicholas Franklin at 1:09 pm, Feb 23, 2011

SR BY: CGH	2/23/11	UNLESS OTHERWISE NOTED	THIRD ANGLE PROJECTION	C.D. NO.
CHKD: NAF	2/23/11	BREAK CAST CORNERS!		PART. NO.
ENGR: RWV	2/23/11	BREAK MECH CORNERS!		
MFR:		TOLERANCES	PURCH. NO.	FINISH ASSY. SCHE.
MFG:		UNLESS OTHERWISE NOTED	REF. NO.	NONE
TOOL:		L INEAR	ANGULAR	STR. NO.
FDRT:		±	±	
MAT'L: NOTED		DESCR:		NUMBER
Mueller Co.		41N - 12IN RWGV A2360 W/EVERDUR STEM W/316 SS FASTENERS		6898