

No.	DESCRIPTION	MATERIAL
1	SPUD	CAST LOW LEAD BRASS ALLOY
2	PJ GASKET	BUNA-N ASTM D2000
3	PJ WASHER	POLYPROPYLENE
4	COMPRESSION RING	BRASS ASTM B505 ALLOY C83600
5	COMPRESSION NUT	CAST BRASS ASTM B62 ALLOY C83600

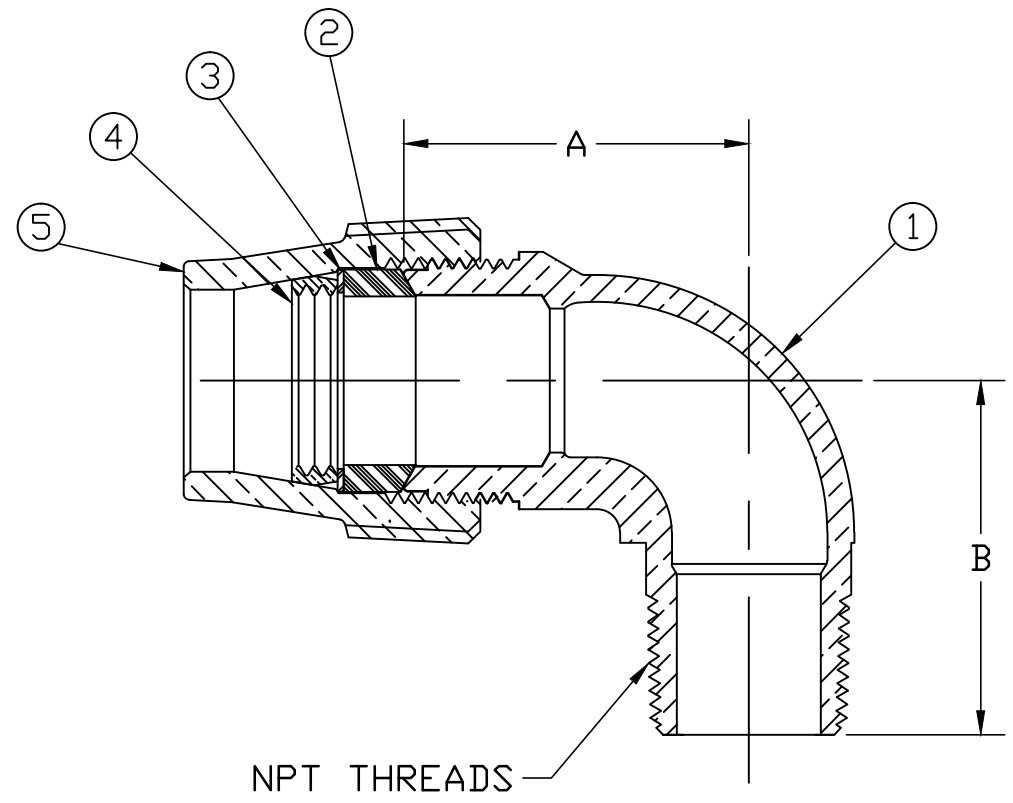

SIZE	A	B
3/4	1.796	1.844
1	2.000	2.000
1x3/4	2.000	2.000
1-1/2	2.750	2.625
2	3.094	2.969

NOTE: ALL WETTED PARTS ARE LOW LEAD BRASS ALLOY

FILEPATH: PRODD-ENG\MUELLER\ASYSUBMITTALS\G15531N

						DRFTR	RWB	3/6/13	Mueller Co.	UNLESS OTHERWISE NOTED SURFACE PREPARATION: BREAK CORNER(S) ----- .000 SURFACE FINISH -- XX RMS TOLERANCE(S): LINEAR ----- ± .000 ANGULAR ----- ± 0°00'	THIRD ANGLE PROJECTION 				
						CHKR						REF. No.	SCALE NONE		
						ENGR									
						MGR									
							BY	DATE							
								STK No:							
								MAT'L:							
								DESCR.	QUARTER BEND LLB SERVICE FITTING (GRIP x MIP)		DWG NUMBER G15531N				
								REV	ECR	DESCRIPTION	DATE	BY	CHKR		
PER EST NO: DXXXX EST FIN WT = 0.0000 lbs															

DWG NUMBER
G15531N
442-MRKTG

TITLE TO AND OWNERSHIP OF THIS ENGINEERING DATA REMAINS IN Mueller Co. NO USE IS TO BE MADE OF THIS DATA EXCEPT AS SPECIFICALLY AUTHORIZED BY Mueller Co. ASSENT ON THE PART OF THE RECIPIENT TO THESE CONDITIONS IS PRESUMED