

MATERIAL OPTION AS CHECKED

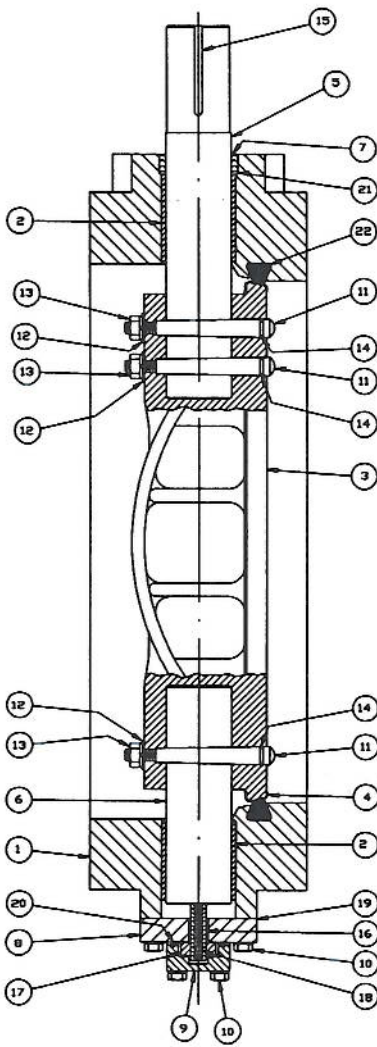
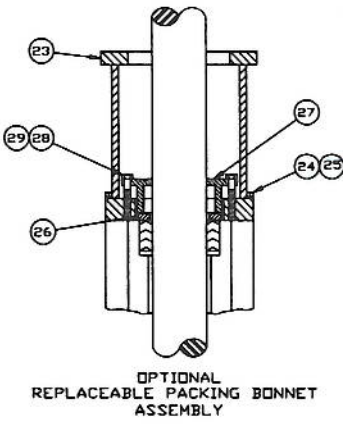

ITEM NO.	DESCRIPTION	MATERIALS	✓
1	BODY	CAST IRON ASTM A-126 CLASS B	
		DUCTILE IRON ASTM A-536 (65-45-12)	
2	BEARINGS	TEFLON LINED, FIBERGLASS BACKED	
3	DISC	CAST IRON ASTM A-48 CLASS 40	
		DUCTILE IRON ASTM A-536 (65-45-12)	
4	DISC EDGE	STAINLESS STEEL ASTM A-240 TYPE 316	
5	TOP STUB SHAFT	STAINLESS STEEL ASTM A-276 TYPE 304	
		STAINLESS STEEL ASTM A-276 TYPE 316	
		STAINLESS STEEL ASTM A-564 TYPE 630 COND. H-1150	
6	BOTTOM STUB SHAFT	STAINLESS STEEL ASTM A-276 TYPE 304	
		STAINLESS STEEL ASTM A-276 TYPE 316	
		STAINLESS STEEL ASTM A-564 TYPE 630 COND. H-1150	
7	PACKING	RUBBER (BUNA-N)	
		RUBBER (EPDM)	
8	BOTTOM COVER	CAST IRON ASTM A-126 CLASS B	
		DUCTILE IRON ASTM A-536 (65-45-12)	
9	BOTTOM COVER CAP	CAST IRON ASTM A-126 CLASS B	
		DUCTILE IRON ASTM A-536 (65-45-12)	
10	CAP SCREWS	CARBON STEEL	
		STAINLESS STEEL TYPE 304	
11	TAPER PINS	STAINLESS STEEL TYPE 316	
		STAINLESS STEEL ASTM A-564 TYPE 630 COND. H-1150	
12	LOCKWASHERS	STAINLESS STEEL TYPE 304	
		STAINLESS STEEL TYPE 316	
13	HEX NUTS	STAINLESS STEEL TYPE 304	
		STAINLESS STEEL TYPE 316	
14	O-RINGS	RUBBER BUNA-N	
		RUBBER (EPDM)	
15	KEY	CARBON STEEL AISI 1045	
16	THRUST BEARING STUD	STAINLESS STEEL TYPE 304	
		STAINLESS STEEL TYPE 316	
		STAINLESS STEEL ASTM A-564 TYPE 630 COND. H-1150	
17	THRUST COLLAR	BRONZE ASTM B-505 ALLOY C93200	
18	GROOVE PIN	ALLOY STEEL	
19	BOTTOM COVER GASKET	NON ASBESTOS MATERIAL ASTM F104	
20	O-RING	RUBBER BUNA-N	
		RUBBER (EPDM)	
21	PACKING RETAINER	NYLON	
22	RUBBER SEAT	RESILOSEAL R (BUNA-N)	
		RESILOSEAL Z (EPDM)	
23	BONNET	CAST IRON ASTM A-48 CLASS 40	
24	LOCKWASHERS	CARBON STEEL	
25	CAP SCREWS	ALLOY STEEL SAE GR 8	
26	PACKING GLAND	BRONZE SAE 660	
27	FOLLOWER	BRONZE ASTM B-504 ALLOY C93200	
28	CAP SCREWS	CARBON STEEL SAE GR 2	
29	LOCKWASHER	CARBON STEEL	

- NOTES:
- CAST IRON IS THE STANDARD BODY MATERIAL FOR VALVES WITH CLASS 150B VALVE.
  - DUCTILE IRON IS THE STANDARD BODY MATERIAL FOR CLASS 250 VALVES AND AN UPGRADE FOR 150B VALVES.
  - SHAFT MATERIAL FOR XP250 AND XP250 II IS STAINLESS STEEL ASTM A-564 TYPE 630 CONDITION H-1150. THESE VALVES ARE NOT AVAILABLE WITH 304 OR 316 SS.

REV	DATE	BY	DESCRIPTION	APP.
8-23-08	CEM		CORRECTED NOTES	
2-2-08	CEM		REMOVED CI ASTM A-48 OPTION	JR
8-1-06	CEG		REMOVED 304 & 316 OPTION	JR
8-22-06	CEG		ADD B3 OPTION FOR BOT COVER & CAP	JR

**Mueller Co.**

PARTS AND MATERIAL LIST  
30" & UP LINESEAL III & XP250  
BUTTERFLY VALVE

SCALE NONE DATE 2-04-05

DRAWN BY AAT CHECKED BY ES

APPROVED GA=BORDER

DRWG. NO. GA-11338MS REV 4