

No.	DESCRIPTION	MATERIAL
1	KEY CAP	CAST BRASS ASTM B62 ALLOY C83600
2	PIN	BRASS ASTM B16 ALLOY C36000
3	SPRING WASHER	PHOS BRONZE
4	O-RING	EPDM ASTM D2000
5	KEY	CAST LOW LEAD BRASS ALLOY
6	BODY	CAST LOW LEAD BRASS ALLOY
7	SADDLE NUT	CAST BRASS ASTM B62 ALLOY C83600
8	SNAP RING	PHOS BRONZE
9	RUBBER GASKET	NITRILE ASTM D2000

No.	DESCRIPTION	MATERIAL
10	BODY	CAST LOW LEAD BRASS ALLOY
11	ORING	EP ASTM D2000 RUBBER
12	GRIP RING	CELCON M90 RED CF2001

NOTE: ALL WETTED PARTS ARE LOW LEAD BRASS ALLOY

METER CONNX SIZE	A	B	C
5/8 x 3/4	1.688	1.719	2.438
5/8 x 3/4 x 3/4	1.688	1.719	2.438
5/8 x 3/4 x 1	1.688	1.641	2.578
1	1.938	2.031	2.578

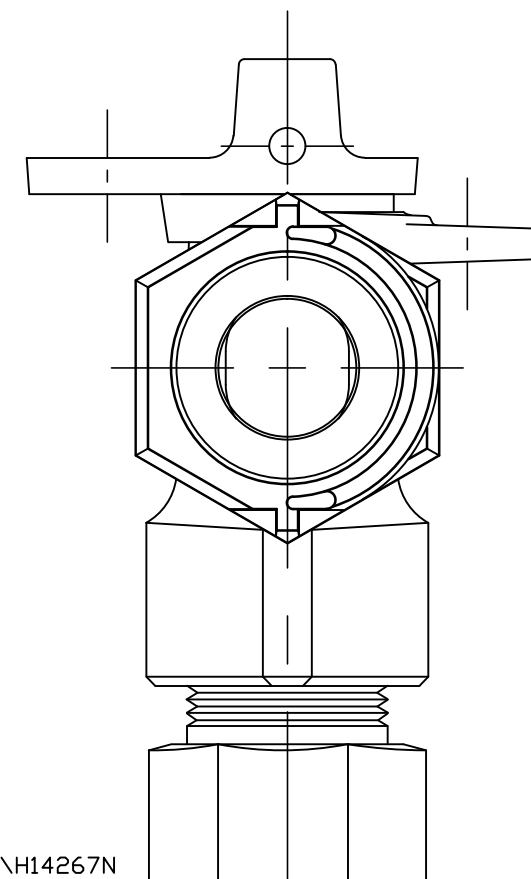
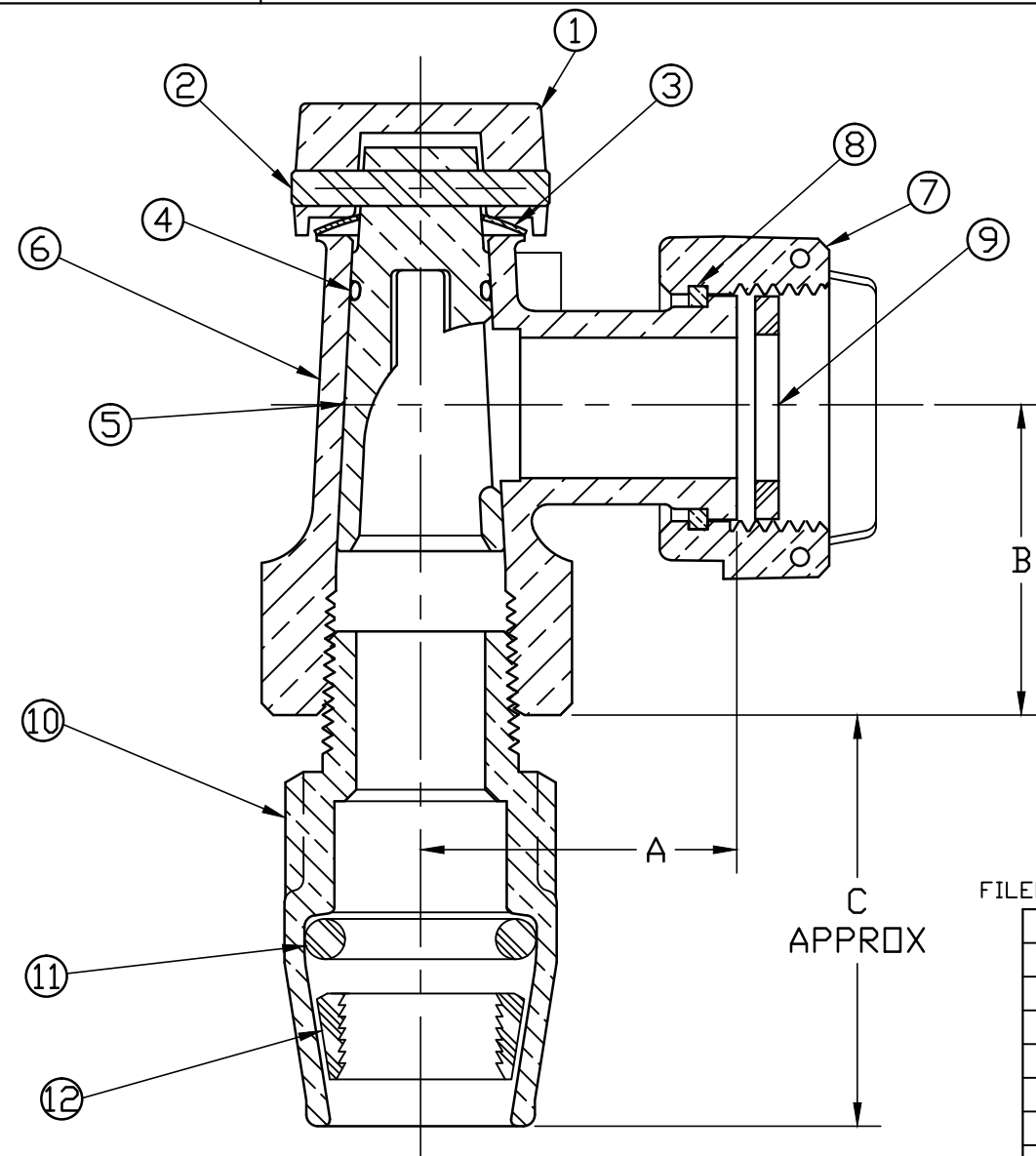

FILEPATH: PROD-ENG\MUELLER\ASYSUBMITTALS\H14267N

REV	ECR	DESCRIPTION	DATE	BY	CHKR

DRFTR RWB 2/17/15
 CHKR
 ENGR
 MGR
 BY DATE
 STK No:
 MAT'L:
 DESCR.



UNLESS OTHERWISE NOTED
 SURFACE PREPARATION:
 BREAK CORNER(S) ----- .000
 SURFACE FINISH -- XX RMS
 TOLERANCE(S):
 LINEAR ----- ± .000
 ANGULAR ----- ± 0°00'

THIRD ANGLE PROJECTION

 REF. No. SCALE
 NONE

ANGLE METER STOP - LLB
 (MTR x CTS PE INSTA-TITE)

DWG NUMBER
 H14267N

DWG NUMBER
 H14267N
 442-MRKTG

TITLE TO AND OWNERSHIP OF THIS ENGINEERING
 DATA REMAINS IN Mueller Co. NO USE IS TO BE
 MADE OF THIS DATA EXCEPT AS SPECIFICALLY
 AUTHORIZED BY Mueller Co. ASSENT ON THE PART
 OF THE RECIPIENT TO THESE CONDITIONS IS PRESUMED

PER EST NO: DXXXX EST FIN WT = 0.0000 lbs