

No.	DESCRIPTION	MATERIAL
1	SPUD	CAST LOW LEAD BRASS ALLOY
2	COPPER TUBE NUT	CAST BRASS ASTM B62 ALLOY C83600

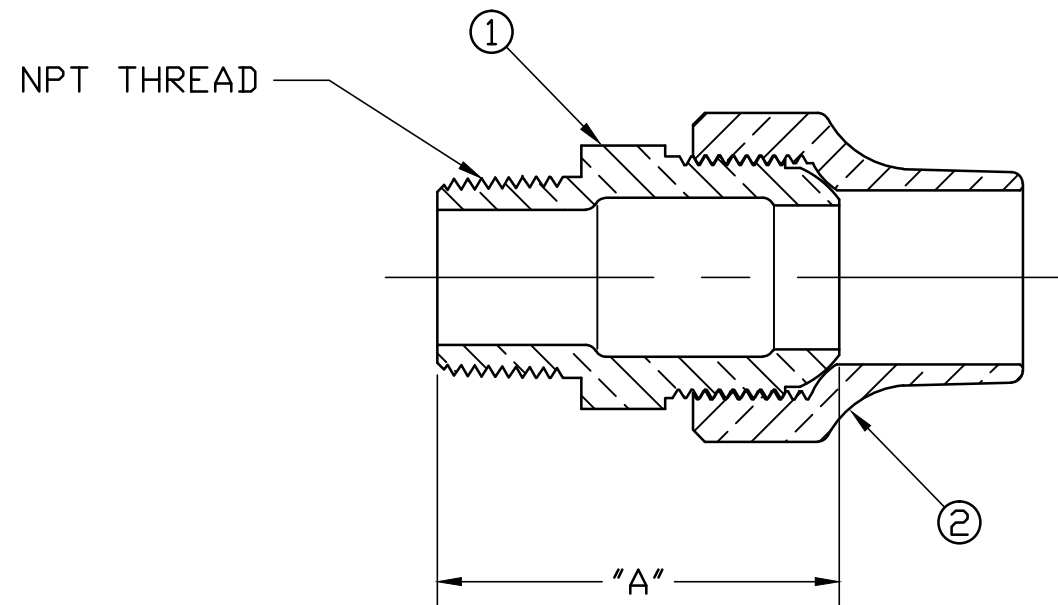

SIZE	A	NPT
1/2	2.03	1/2"
1/2x3/4	2.09	3/4"
5/8x1/2	2.03	1/2"
3/4	2.12	3/4"
3/4x1/2	2.03	1/2"
3/4x1	2.38	1"
1	2.66	1"
1x3/4	2.53	3/4"
1-1/4	3.09	1-1/4"
1-1/2	3.34	1-1/2"
2	3.98	2"

**NOTE:** ALL WETTED PARTS ARE LOW LEAD BRASS ALLOY

FILEPATH: PROD-ENG\MUELLER\ASYSUBMITTALS\H15425N

DRFTR	JGarvin	2/12/10	<b>Mueller Co.</b>		
CHKR					
ENGR					
MGR					
			UNLESS OTHERWISE NOTED	THIRD ANGLE PROJECTION	
			SURFACE PREPARATION:		
			BREAK CORNER(S) ---- .000		
			SURFACE FINISH -- XX RMS	REF. No.	
			TOLERANCE(S):	SCALE	
			LINEAR ----- ± .000	FULL	
			ANGULAR ----- ± 0°00'		
			STK No:		
			MAT'L:		
			DESCR.	PART NUMBER	
			STRAIGHT SERVICE FITTING	H15425N	
			LOW LEAD BRASS (CS x MIP)		
REV	ECR	DESCRIPTION	DATE	BY	CHKR
PER	EST NO:	DXXXX	EST FIN	WT = 0.0000	lbs

PART NUMBER  
H15425N  
442-MRKTG

TITLE TO AND OWNERSHIP OF THIS ENGINEERING DATA REMAINS IN Mueller Co. NO USE IS TO BE MADE OF THIS DATA EXCEPT AS SPECIFICALLY AUTHORIZED BY Mueller Co. ASSENT ON THE PART OF THE RECIPIENT TO THESE CONDITIONS IS PRESUMED