

VALVE SIZE	GEAR SIZE & RATIO	A	B	C	D	E	F	G	H	J	K	L	M	N	P	Q	S	T
2.5	M2 (20:1)	7.5	3.41	3.50	2.5	5.50	7.00	0.75	4	---	0.69	2.5	6	4.75	4.75	1.75	2.00	
3	M2 (20:1)	8	3.41	3.75	3	6.00	7.50	0.75	4	---	0.75	2.5	6	4.75	4.75	1.75	2.00	
4	M3 (30:1)	9	4.38	4.50	4	7.50	9	0.75	6	0.63	2	0.94	3	6	9.50	8	2.00	2.56
5	M3 (30:1)	10	5.63	5.75	5	8.50	10	0.88	6	0.75	2	0.94	3	6	9.50	8	2.00	2.56
6	M3 (30:1)	10.50	5.63	5.75	6	9.50	11	0.88	6	0.75	2	1	3	6	9.50	8	2.00	2.56
8	M5 (50:1)	11.50	7.56	7.63	8	11.75	13.50	0.88	6	0.75	2	1.13	6	12	11.25	8	2.25	3.16
10	M8 (80:1)	13	9.25	8.88	10	14.25	16	1	8	0.88	4	1.19	6	12	11.63	10	2.00	4.63
12	M8 (80:1)	14	10.88	10	12	17.00	19	1	8	0.88	4	1.25	6	12	11.63	10	2.00	4.63

ABOVE GROUND GEAR
W/ HANDWHEEL
OPTION

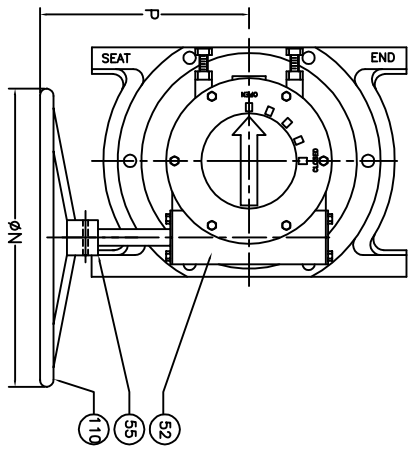

BURIED GEAR
W/ 2" NUT
OPTION

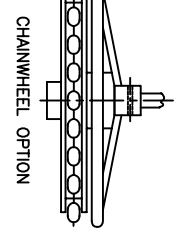
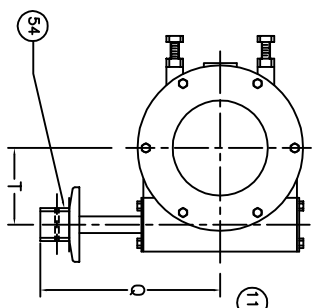

SIZE	GEAR	# OF TURNS
2.5"	20:1	5
3"	20:1	5
4"	30:1	7 1/2
5"	30:1	7 1/2
6"	30:1	7 1/2
8"	50:1	12 1/2
10"	80:1	20
12"	80:1	20

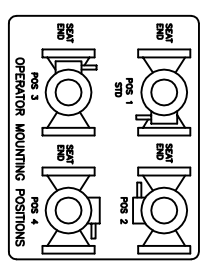

THIS DRAWING IS THE PROPERTY OF
HENRY PRATT COMPANY
AND MUST NOT BE USED IN ANY WAY
PREJUDICIAL TO THEIR INTERESTS

*RISER RING IS ONLY ON 2-1/2" TO 8" VALVE

111	1	CHAINWHEEL	DUCTILE IRON
110	1	SPRING PIN	STEEL
103	1	KEY	STEEL
*101	1	RISER RING	STEEL
55	1	HANDWHEEL	DUCTILE IRON
54	1	2" NUT	DUCTILE IRON
53	2	SLEEVE BEARING	BRONZE
52	1	WORM GEAR	STEEL
51	1	QUAD GEAR	DUCTILE IRON
50	1	HOUSING	STEEL
10	2	GRIT SEAL	PTFE
9	1	SEAL RETAINING RING	BRASS
8	AR	H.H. CAP SCREW	STEEL
7	1	O-RING	ELAS AS SPEC.
6	2	U-CUP SEAL	ELAS AS SPEC.
5	1	SNAP RING	STEEL
4	2	SLEEVE BEARING	STN. STEEL
3	1	PLUG	DUCTILE IRON
2	1	CAP	CAST IRON
1	1	BODY	CAST IRON

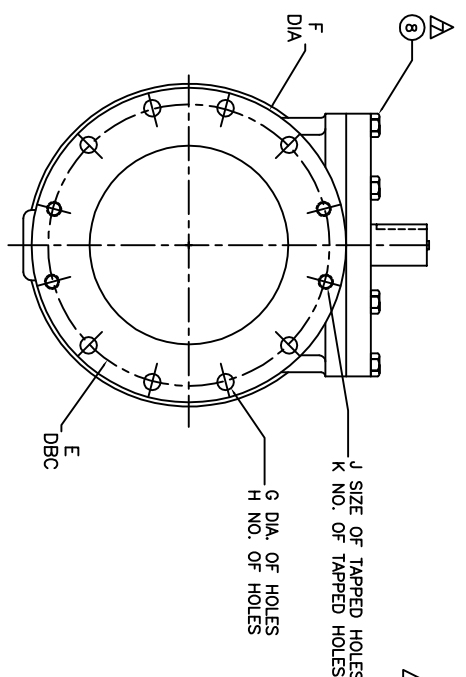
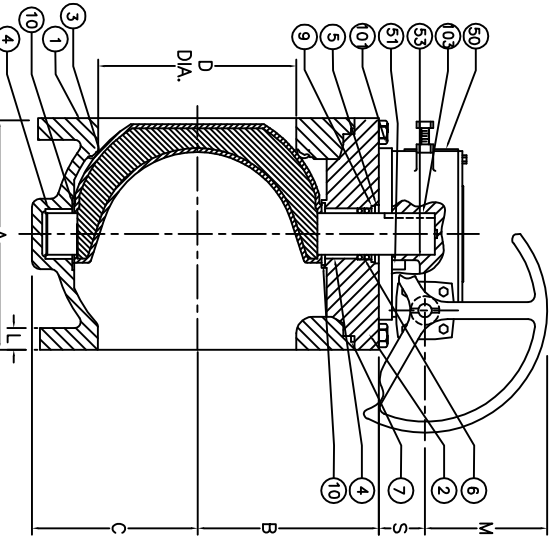

DATE	REVISIONS	BY	TITLE
1/12/97	REVISED GEAR DIA. FROM 2.5" TO 2.5" (NO CHANGE)	AL	FIG. 601
2/11/98	ITEM 8 WAS RENAMED FROM "O-RING" TO "H.H. CAP SCREW"	AL	2-1/2" TO 12"
3/20/00	ITEM 50 MATERIAL CHANGED FROM CAST TO DUCTILE IRON	JC	PLUG VALVE, FLANGED, GEAR OPERATED, W/HANDWHEEL, 2" NUT, OR CHAINWHEEL OPTION
4/02/10	REMOVED DATA FOR 1"	BT	
5/09/10	REMOVED DATA FOR 1.5"	BT	
6/09/12	REMOVED DATA FOR 2" & 3" DIA.	AM	
7/07/13	ADDED ITEM 10 AND ITEM 100 TO DRAWING	AL	
8/07/13	ADDED DIMENSION ITEM TO DRAWING	AL	

FIG. 601
2-1/2" TO 12"
PLUG VALVE, FLANGED,
GEAR OPERATED,
W/HANDWHEEL, 2" NUT,
OR CHAINWHEEL OPTION

DWG. NO. HP49110