

S.M.A.R.T.

Water Quality Monitoring and Flushing

HYDRO-GUARD®

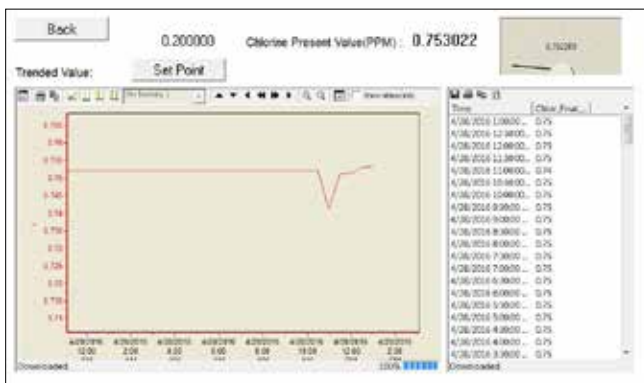
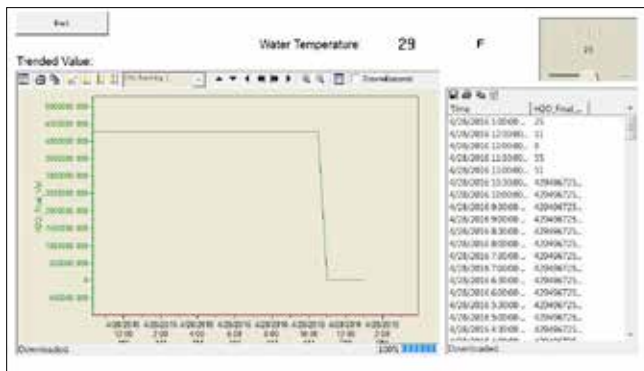

The Hydro-Guard® S.M.A.R.T. Flushing System is the ultimate automated flush management system. S.M.A.R.T. enabled flushing can be set to occur either in response to real-time analysis of local water quality or by time-based schedule. What's more, it allows two-way communication and remote flushing unit management via either a secure web portal or a secure interface with the end-user's existing SCADA via Modbus TCP protocol.

By way of this two-way communication, the utility can receive real-time updates from each Hydro-Guard unit in the distribution system equipped with S.M.A.R.T. controller. It can be integrated with a residual analyzer and a variety of other water quality management devices. This integration will allow the Hydro-Guard S.M.A.R.T. flushing system to flush only when the disinfectant residuals or other water quality conditions exceed the parameters established by the end-user, in addition to flushing on a set time-based schedule. S.M.A.R.T. technology takes water conservation and cost management to a whole new level of potential savings.

Mueller Co.'s most advanced monitoring and flushing solution, Hydro-Guard S.M.A.R.T., gives the end user real-time information from the distribution end points so that more efficient and effective decisions can be made by management and field personnel.

Comply with EPA Stage II DBPR standards while saving time and costs. Calculate your ROI using our online calculator at www.muellercompany.com/hydro-guard

Benefits of Hydro-Guard S.M.A.R.T. Flushing System:

- Engineered for ease of installation, durability, and minimum maintenance
- Available with 120 volt AC power ; alternative power options are available upon request
- Integration with existing SCADA and water quality analyzers
- Communicate via Cellular (GSM or CDMA) Ethernet, 900MHz or 2.4GHz, WiFi, or BlueTooth®



End-user receives real-time water quality from the S.M.A.R.T. Hydro-Guard unit.

Mueller Co.

Reliable Connections®

Standard Features:

- Real-time water quality data management log
- Weather-proof protective enclosure, mounting system and weather-proof fittings; multiple access doors
- Hydro-Guard flushing system (model to be determined through consultation)
- 120 volt AC power
- Dechlorination
- Sampling port

Options and Accessories:

- Ground fixed-post mounted or mobile trailer mounted system
- On-site data storage
- Enclosure tamper alert system/notification
- High wattage space heater for cold climates; Heat tape for added freeze protection
- Communication Options: Cellular, Ethernet, 900mHz or 2.4GHz, WiFi, or BlueTooth®
- Water flow detection or flow metering
- Multiple water quality sensors available (pH, turbidity, temperature, flow, pressure, and chlorine)

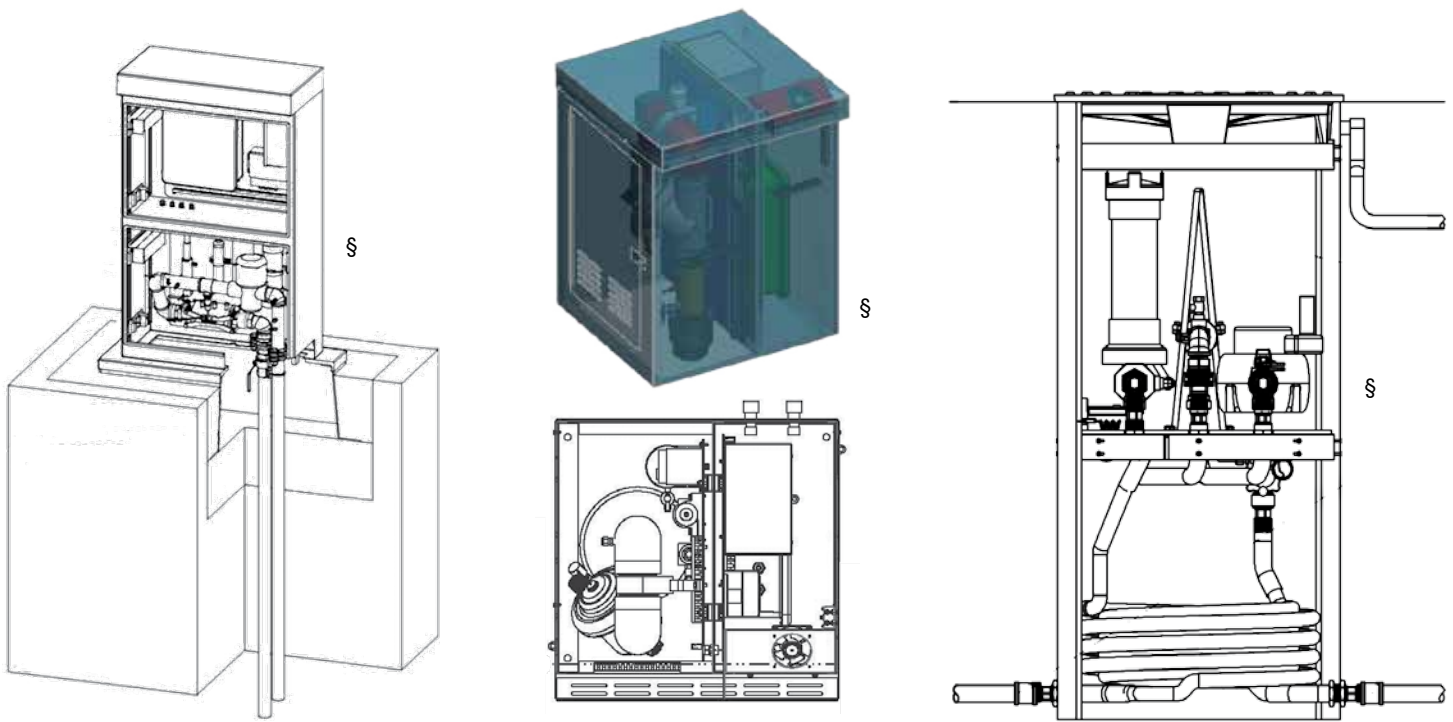

HG-7 with S.M.A.R.T. technology

Low-Profile S.M.A.R.T. unit
(with multi-parameter water quality sensors)

HG-8 with S.M.A.R.T. technology



Mueller Co., LLC
633 Chestnut St., Suite 1200
Chattanooga, TN 37450
www.muellercompany.com

Toll Free: 1.800.423.1323
Canada: 1.705.719.9965
moreinfo@muellercompany.com

Copyright © 2016 Mueller Co., LLC. All Rights Reserved.

The trademarks, logos and service marks displayed in this document herein are the property of Mueller Co., LLC, its affiliates or other third parties. Products above marked with a section symbol (§) are subject to patents or patent applications. For details, visit www.mwppat.com. These products are intended for use in potable water applications. Please contact your Mueller Sales or Customer Service Representative concerning any other application(s).

Form 12756 - Rev 7/16