

FIRE PROTECTION PRODUCTS

R-2361-6: O.S.&Y. resilient wedge gate valve with flanged ends

- 2" SIZES
- UL 262 Listed and FM 1120/1130 Approved and certified to ANSI/NSF 61 & 372
- Iron body with Mueller® PRO-GARD® Fusion Bonded Epoxy Coated interior and exterior surfaces
- Outside Screw & Yoke (O.S.&Y.)
- Rubber encapsulated iron wedge
- Adjustable packing
- Handwheel – open left or open right
- 200psig (1400 kPa/14 barg) maximum working pressure - 400psig (2800 kPa/28 barg) static test
- Epoxy coating meets or exceeds all applicable requirements ANSI/AWWA C550
- Flanged end drilling complies with ASME/ANSI B16.1 Class 125

Options

- Stainless steel fasteners: Type 316
- ASTM B98-C66100/H02 stem, 304 stainless steel
- Stainless steel stem: Type 304 and Type 316
- EPDM disc and o-rings



PARTS LIST

Catalog Part Number	Description	Material	Material Standard
G-1	Cap Nut	Bronze	ASTM B62/B584
G-3	Hand Wheel	Ductile Iron	ASTM A536 ▼
G-4	Washer	Brass	-
G-5	Bush Nut	Bronze	ASTM B562
G-7	Gland Nut	Bronze	ASTM B98
G-8	Packing Gland	Ductile Iron	ASTM A536 ▼
G-10	Gland Bolt	304 Stainless Steel	ASTM F593
G-16	Bonnet Bolts & Nuts	304 Stainless Steel	ASTM F593 (bolt) / ASTM F594 (nut)
G-23	Stem Packing	Lubricated Flax	-
G-206	Guide Cap Bearings	Acetal	-
G-209	Wedge, Rubber Encapsulated	Cast Iron***	ASTM A126 CL.B
G-211	Bonnet Gasket	EPDM	ASTM D2000
G-212	Body	Ductile Iron	ASTM A536 ▼
G-213	Stem	Bronze	ASTM B138
G-215	Bonnet & Yoke	Ductile Iron	ASTM A536 ▼
G-217	O-ring	Nitrile	ASTM D2000
G-218	Disc Nut	Bronze	ASTM B584
G-219	Stem Nut Pin	Stainless Steel	Type 304

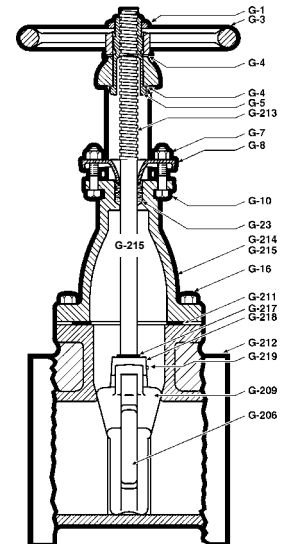

DIMENSIONS

Dimension*	Size
	2"
A	16.69"
AA	14.09"
E	7.00"
R	6.00"
FF	7.00"
UU	4.75"
FFF (number and size of holes)	4-0.625"
Turns to open	8.50"
Weight (lbs.)*	41

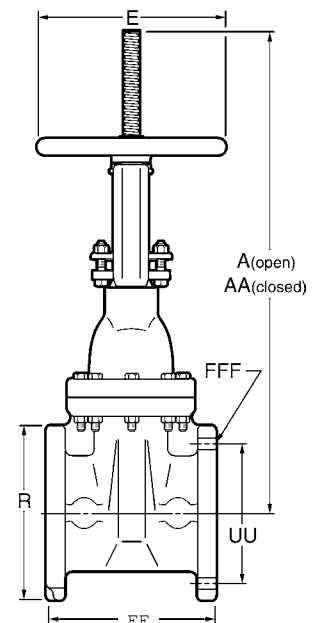

See page B-1-18 for ordering instructions.

NOTE: Flanged end dimensions and drilling comply with ANSI B16.1, class 125.

*All dimensions are in inches. All weights are in pounds and are approximate.

**Fully encapsulated in molded rubber with no iron exposed.

++ Manufacturer's option to upgrade material to Ductile iron ASTM A536

▼ Material strength ASTM A536 65-45 minimum