

8001 SERIES 14"- 36" SWING TYPE LEVER AND WEIGHT CHECK VALVE DIMENSIONS-FL.X FL.



13.7

Shaded area indicates changes Rev. 6-15

14"- 16" Check Valve

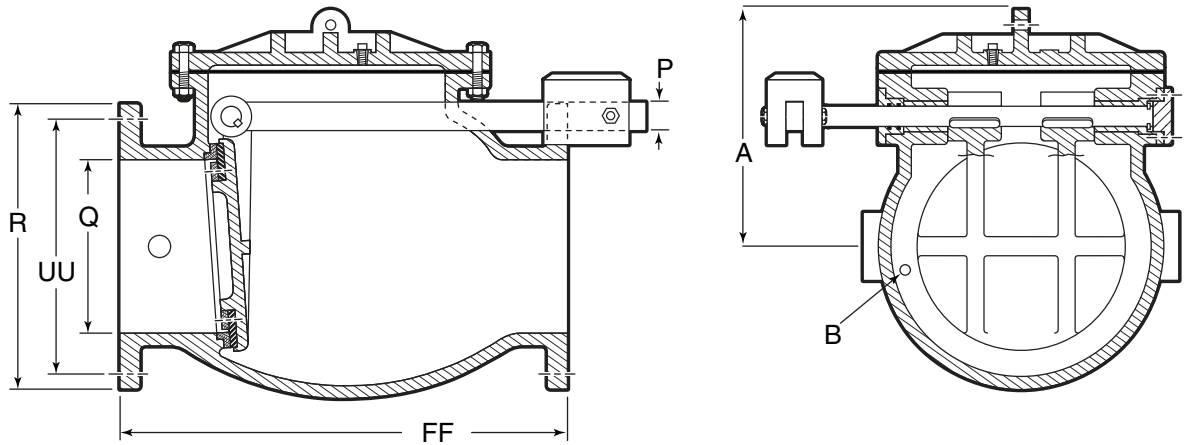

18"- 36" Check Valve

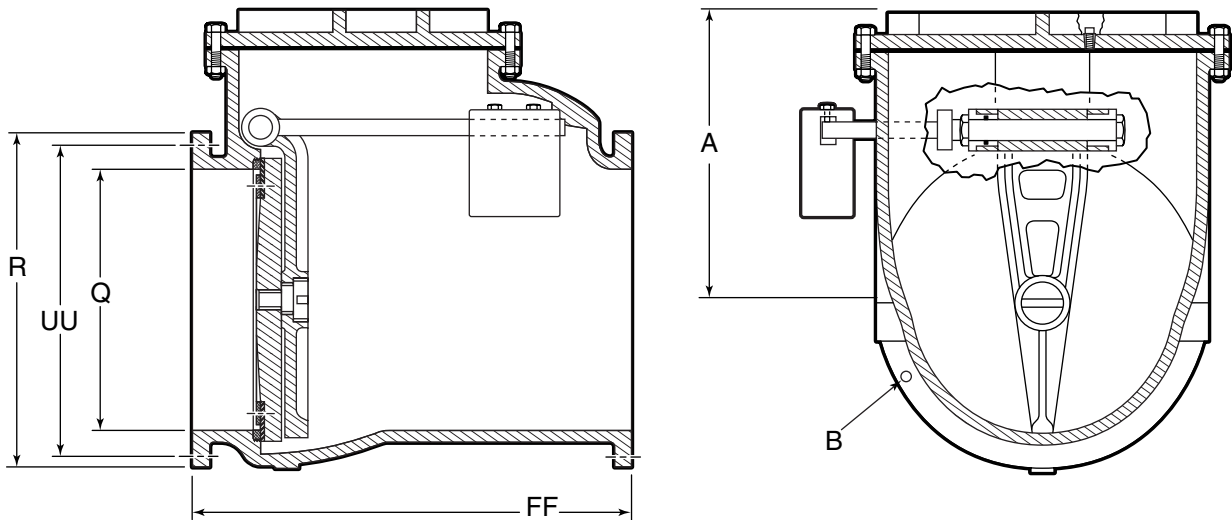

Dimension**	Size*						
	14"	16"	18"	20"	24"	30"	36"
Q	14.00	16.00	18.13	20.13	24.00	30.00	36.00
R	21.00	23.50	25.00	27.50	32.00	38.75	46.00
FF	31.00	36.00	40.00	40.00	48.00	52.50	60.50
A	19.31	21.50	25.13	27.00	31.63	36.38	40.00
P	1.75	2.00	-	-	-	-	-
UU (bolt circle diameter)	18.75	21.25	22.75	25.00	29.50	36.00	42.75
B (number and size of bolts)	12 - 1.13	16 - 1.13	16 - 1.25	20 - 1.25	20 - 1.38	28 - 1.38	32 - 1.63
Weight	1,111	1,450	1,804	2,194	3,076	5,955	7,645

*Nominal

**All dimensions are in inches. All weights are in pounds and are approximate.