

No.	DESCRIPTION	MATERIAL
1	SPUD	CAST LOW LEAD BRASS ALLOY
2	PJ CPLG NUT	CAST BRONZE ASTM B62 ALLOY C83600
3	PJ GASKET	ASTM D2000 NITRILE
4	PJ WASHER	POLYPROPYLENE

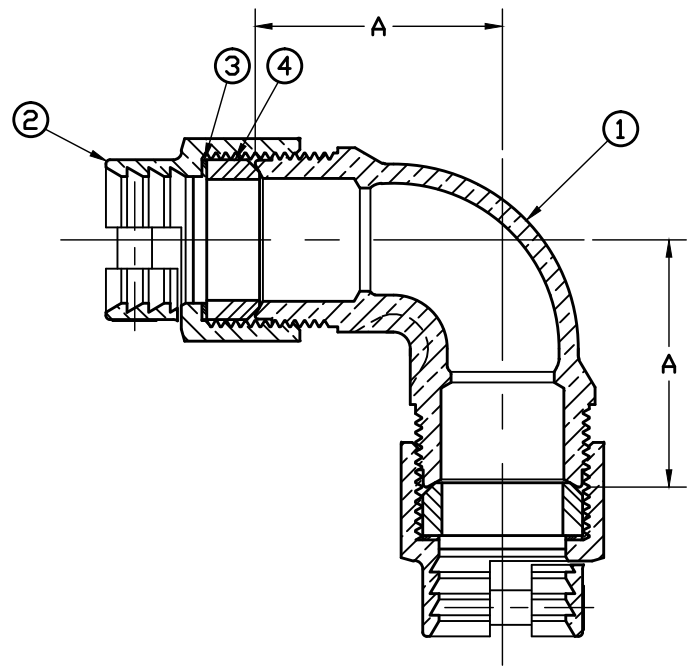

SIZE	A	WRENCH FLATS
3/4	1.79	1.09@BODY
1	2.00	1.31@BODY
1x3/4	2.00	1.34@BODY
1-1/2	2.75	2.22@ENDS
2	3.09	2.72@ENDS

NOTE: ALL WETTED PARTS ARE LOW LEAD BRASS ALLOY

FILEPATH: PRODD-ENG\MUELLER\APPROVED\P15526N

						DRFTRJGarvir	7/16/10	Mueller Co.	UNLESS OTHERWISE NOTED SURFACE PREPARATION: BREAK CORNER(S) ---- .000 SURFACE FINISH -- XX RMS TOLERANCE(S): LINEAR ----- ± .000 ANGULAR ----- ± 0°00'	THIRD ANGLE PROJECTION	
										REF. No.	SCALE NONE
						BY	DATE				
						STK No:					
						MAT'L:		DESCR.		PART NUMBER	
								1/4 BEND SERVICE FITTING LOW LEAD BRASS(PJ CTS ENDS)		P15526N	
PER EST NO: DXXXX EST FIN WT = 0.0000 lbs											

PART NUMBER
P15526N
442-MRKTG