

Rev. 2-06 Shaded area indicates change.

- Catalog number–
A-2360-8 threaded ends
- Sizes – 2", 2-1/2", 3"
- Meets or exceeds all applicable requirements of ANSI/AWWA C509 Standard, UL Listed, FM Approved, and certified to ANSI/NSF 61.
- Threaded end dimensions comply with ANSI B2.1
- Iron body with nominal 10 mils MUELLER® Pro-Gard™ Epoxy Fusion Coated interior and exterior surfaces
- Epoxy coating meets or exceeds all applicable requirements of ANSI/AWWA C550 Standard and is certified to ANSI/NSF 61
- Iron wedge, symmetrical & fully encapsulated with molded rubber; no exposed iron
- Non-rising stem (NRS)
- Triple O-ring seal stuffing box (2 upper & 1 lower O-rings)
- 2" square wrench nut (optional handwheel available) – open left or open right
- 250 psig (1723 kPa) maximum working pressure, 500 psig (3447 kPa) static test pressure
- 3" size – UL Listed, FM Approved: 200 psig (1379 kPa)



A-2360-8

Options

See page 10.40 for more information on Resilient Wedge Gate Valve options

- Position indicators
- Stainless steel fasteners: Type 316
- ASTM B98-C66100/H02 stem
- Handwheel

Resilient wedge gate valve parts

Catalog Part No.	Description	Material	Material standard
G-16	Bonnet Bolts & Nuts	Stainless Steel	Type 304
G-41	Stuffing Box Bolts & Nuts	Stainless Steel	Type 304
G-49	Stem O-rings (3)	Rubber	
G-200	Wrench Nut Cap Screw	Stainless Steel	Type 304
G-201	Stuffing Box Seal	Rubber	
G-202	Wrench Nut	Cast Iron	ASTM A126 CL.B
G-203	Stem	Bronze	ASTM B138
G-204	Hand Wheel (not shown)	Cast Iron	ASTM A126 CL.B
G-205	Stem Nut	Bronze	ASTM B62
G-206	Guide Cap Bearings	Celcon	
G-207	Stuffing Box	Cast iron	ASTM A126 CL.B
G-208	Anti-friction Washers (2)	Celcon	
G-209	Wedge, Rubber Encapsulation	Cast Iron* SBR	ASTM A126 CL.B --
G-210	Bonnet	Cast Iron	ASTM A126 CL.B
G-211	Bonnet Gasket	Neoprene	
G-212	Body	Cast Iron	ASTM A126 CL.B

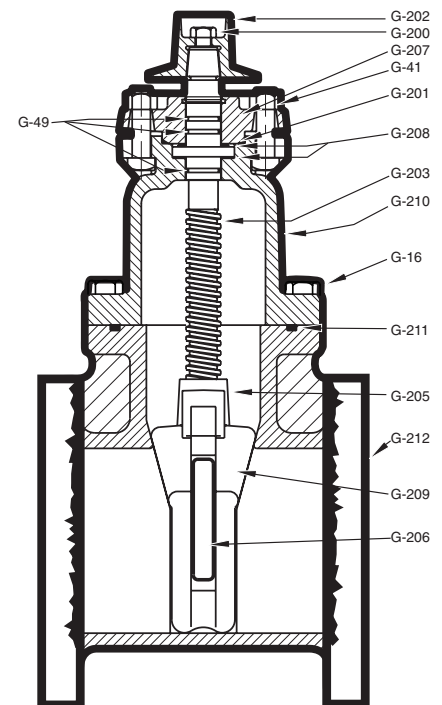

* Fully encapsulated in molded rubber with no iron exposed