

# COPPER METER YOKES WITH HORIZONTAL INLET AND OUTLET (FOR 1-1/2" & 2" FLANGED METERS)

**Mueller Co.** **8A.33**

Rev. 8-04

8A - COPPER YOKES

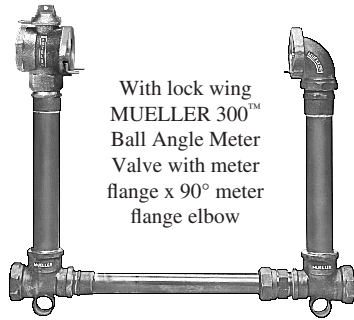

With lock wing  
MUELLER 300™  
Ball Angle Meter  
Valve with meter  
flange x 90° meter  
flange elbow

**B-2422**

FIP end inlets  
and outlets

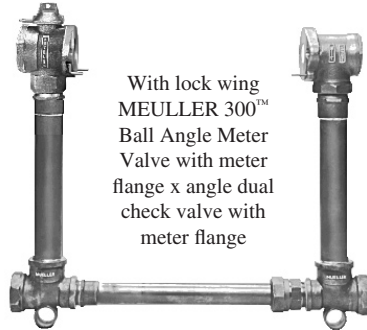

With lock wing  
MUELLER 300™  
Ball Angle Meter  
Valve with meter  
flange x angle dual  
check valve with  
meter flange

**B-2422-2**

FIP end inlets  
and outlets

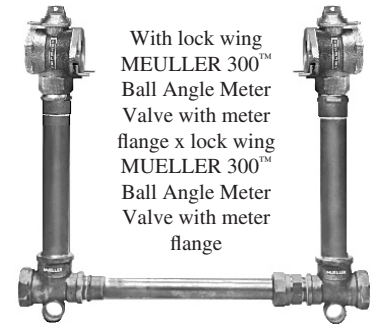

With lock wing  
MUELLER 300™  
Ball Angle Meter  
Valve with meter  
flange x lock wing  
MUELLER 300™  
Ball Angle Meter  
Valve with meter  
flange

**B-2422-00**

FIP end inlets  
and outlets

## 1-1/2" and 2" Copper meter setters

Catalog number	B-2422	B-2422-2*	B-2422-00
Description	With lock wing MUELLER 300™ Ball Angle Meter Valve x 90° meter flange elbow.	With lock wing MUELLER 300™ Ball Angle Meter Valve x angle dual check valve with meter flange.	With lock wing MUELLER 300™ Ball Angle Meter Valve x lock wing MUELLER 300 Ball Angle Meter Valve.

\*For ASSE Approved canister dual check - add 6A for regular or 6D for drain

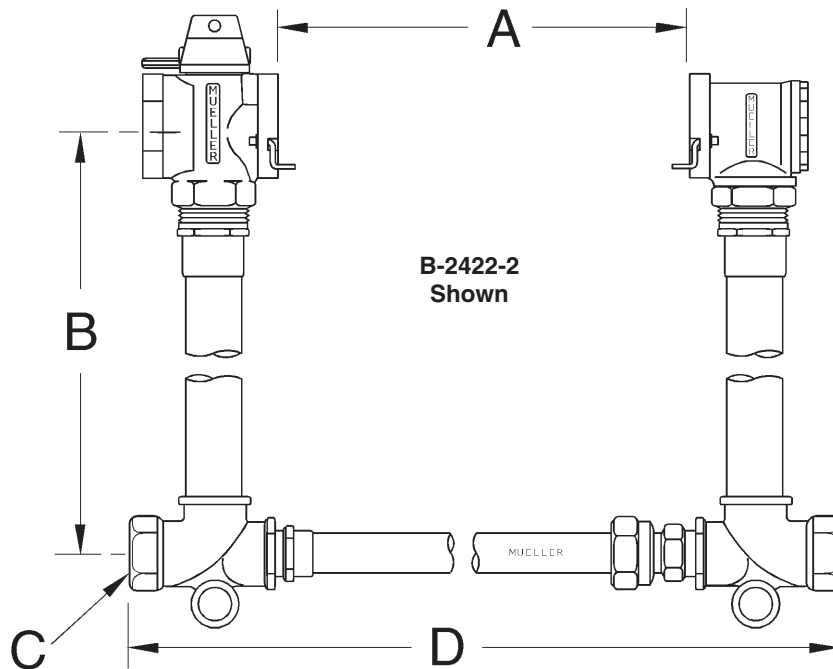

## Dimensions

Meter size	1-1/2"	2"
Dimension A*	13.25"	17.25"
Dimension B - riser height	12", 15", 18", 21", 24", 27"	12", 15", 18", 21", 24", 27"
Dimension C - nominal pipe size of inlet and outlet	1-1/2"	2"
Dimension D*	21.50"	26.63"

\*Adjustable dimension. Copper tubing in the tie bar can be cut to accommodate shorter meters. Adjustment affects both A and D dimensions.  
See section 6 for end connections that can be used with these yokes.

**SPECIFY METER SIZE, RISER HEIGHT AND CATALOG NUMBER.**