

Mueller Co.

Operating Instructions for

MUELLER® MODERN CENTURION® FIRE HYDRANT

Mueller Co.

MAIN OFFICE and PLANT

500 West Eldorado Street

Decatur, Illinois 62522

www.muellercompany.com

! WARNING

Before removing any bolts(s) holding the hydrant together, shut off gate valve to isolate hydrant from main water source. Loosen (do not remove) one nozzle cap two turns and check for water under pressure inside hydrant - bleed off any pressure, then remove nozzle cap completely. Open hydrant main valve completely. A continuous flow of water, no matter how slight, indicates hydrant is not properly isolated from the main water supply, and that problem must be corrected before any hydrant disassembly can proceed. Disassembly of hydrant with pressurized water acting against the main valve could result in unexpected ejection of hydrant parts, debris or high-pressure water stream, which could cause serious bodily injury.

MUELLER® MODERN CENTURION® FIRE HYDRANT

Inspection and Maintenance

To ensure their readiness for instantaneous use, all fire hydrants should be inspected and tested at six-month intervals.

Inspect visually for damaged or missing parts.

Unscrew one Nozzle Cap slightly and tighten the others. Open hydrant fully. Tighten the loose Nozzle Cap when water starts flowing. Remove Oil Filler Plug to check oil level and make sure Stem O-rings are in good condition. (If oil level is low, fill as shown on page 3.) Check all Gaskets for leaks. Turn Operating Nut to fully CLOSED position.

If water was coming from Oil Filler Hole, remove Housing and replace the two O-rings. Inspect and clean Stem and replace it if it is corroded or pitted. Check oil level. Replace Housing and retest for leaks.

Use A-367 Brass Sleeve when removing or replacing Housing or Hydrant Barrel to protect O-rings.

Remove one Nozzle Cap and open hydrant fully and flush the Barrel and the hydrant lateral. Turn Operating Nut to fully CLOSED position.

Remove all Nozzle Caps. Clean and lubricate the threads.

Examine the inside of the Barrel to make certain the Drain Valves have completely drained the water from the Barrel. If the water fails to drain from the Barrel, it may be caused by one or more of the following conditions:

1. Water table in ground higher than drains.
2. When hydrant was installed no coarse gravel was put around the Drains and the ground is of such nature that it will not readily absorb water.
3. Drains stopped up by some foreign substance.
4. Failure to leave the Cap off the hydrant to allow air to enter so Barrel will drain.

Replace Nozzle Caps and Oil Filler Plug.

NOTE: The following procedure can be used to open most blocked drain valves.

1. If the water level does not drain and remains in the Barrel at a level just below the nozzles, recap the nozzles hand tight and then back them off 1/4 turn.
2. Open the Main Valve and fill the Barrel as completely as possible.

3. Tighten the Nozzle Caps and close the Hydrant to within two or three turns of full closure for several seconds.
4. Close the Main Valve completely and recheck hydrant drainage. Repeat this procedure if necessary.

The above procedure introduces full line pressure to the Drain Valves and provides the best method to clean the Drain Valves with water pressure.

IMPORTANT – Initial installation of the hydrant MUST BE MADE PROPERLY so the Safety Flange will function in the ground properly. It should be blocked at ground line and around shoe by concrete or some similar substance to prevent the ground from giving away when the Hydrant is struck.

For additional information on Hydrant anchorage, blocking, and drainage see AWWA Standard C600.

The lower and upper barrels of the Mueller MODERN CENTURION Hydrant can be removed from the shoe (with the shoe under pressure) keeping the Main Valve intact with the shoe by leaving the two-drain ring housing bolts in place.

MUELLER® MODERN CENTURION® FIRE HYDRANT

Changing Shoe



1. Tighten Operating Nut to be sure Main Valve is in the fully CLOSED position.

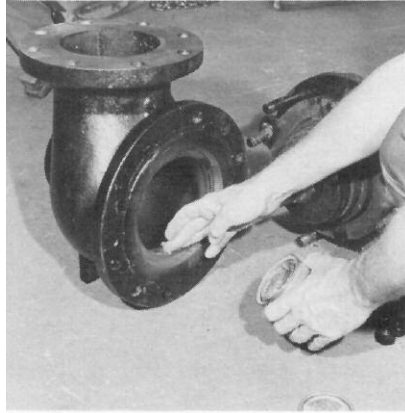

4. Lubricate new Shoe and Bottom Seat Ring O-ring.

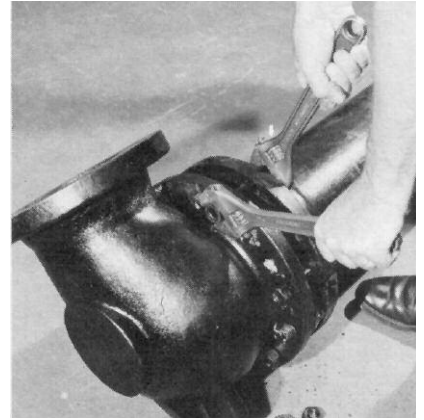

7. Replace Shoe Bolt Nuts. Tighten to approximately 1800 in-lbs. Then tighten Drain Ring Housing Bolt Nuts to approximately 600 in-lbs.



2. Remove all 6 Shoe Bolt Nuts and 2 drain ring housing Bolt Nuts.

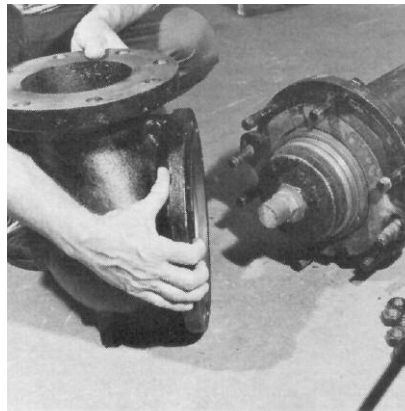

5. Position Shoe to slip in place.

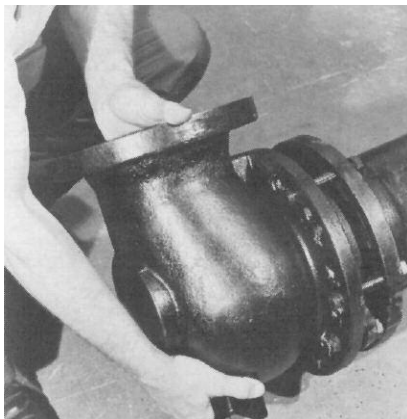

3. Slip off Hydrant Shoe.



6. Slip new Shoe in place being careful not to damage Bottom Seat Ring O-ring.

MUELLER® MODERN CENTURION® FIRE HYDRANT

To Replace Nozzles



1. Unscrew and remove the Nozzle Cap. Using a pointed tool or awl, remove the Nozzle Lock. If Nozzle is retained with retaining screw, use screwdriver to remove screw.



2. Place Nozzle Wrench behind threaded section of Nozzle so that Wrench gaps engage Nozzle drive lugs. Replace Nozzle Cap and tighten until Cap rests loosely against Wrench.



3. Attach a length of pipe over handle end of Wrench and unscrew the Nozzle.



4. Lubricate O-ring on new Nozzle. Screw new Nozzle in place hand tight and place Nozzle Wrench behind threaded section of Nozzle so that Wrench gaps engage Nozzle drive lugs. Screw on Nozzle Cap to hold the Wrench in place. Attach a length of pipe to handle of Nozzle Wrench and tighten.

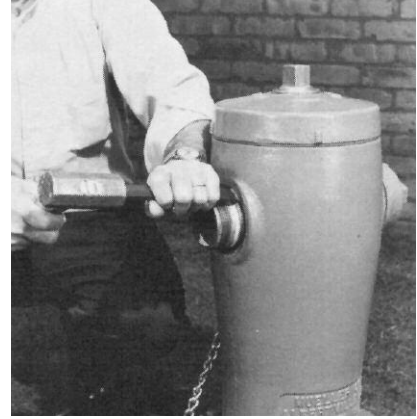

5. Remove Nozzle Cap and drive the Nozzle Lock into position between the Nozzle and Hydrant Barrel using the Nozzle Lock Installation Tool and Brass Hammer. Replace the Nozzle Cap.

NOTE: Wear safety glasses when using a striking tool.

MUELLER® MODERN CENTURION® FIRE HYDRANT

Parts

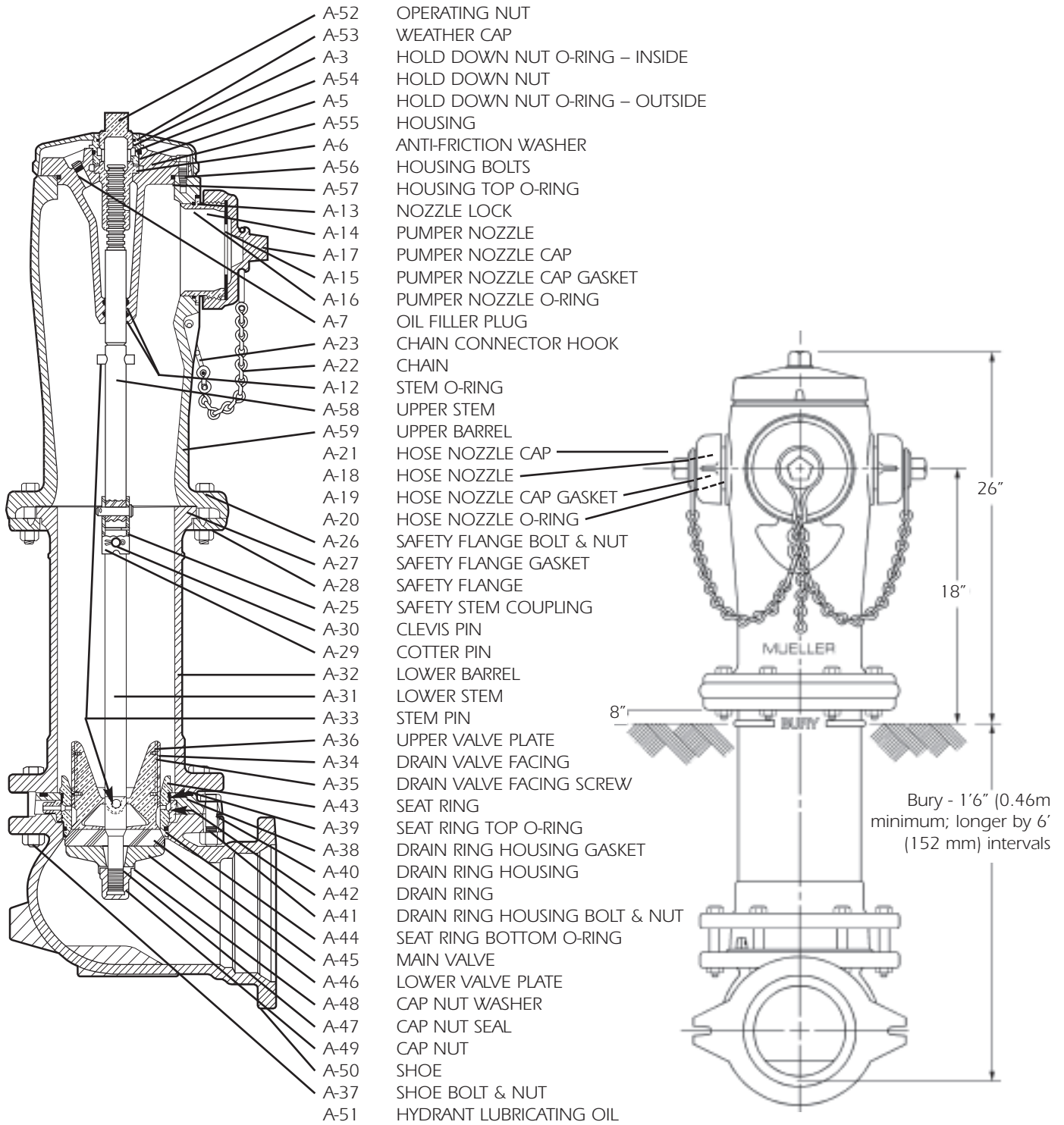

MUELLER® MODERN CENTURION® FIRE HYDRANT

Filling Oil Reservoir

CAUTION: Always fill the oil reservoir with the Bonnet installed, the hydrant in its normal upright position, and the main valve fully closed. If the hydrant is filled with lubricant under any other circumstances, excess lubricant can overflow the reservoir and create a pressure lock. This could result in damage to the seals or Bonnet, or prevent proper hydrant operation.



1. Remove the Weather Cap from the Hydrant.



3. If oil is low, use a small funnel and add MUELLER Hydrant Lubricant.



2. Remove the Oil Filler Plug and check the oil level. Oil should be level with the Oil Filler Plug hole.



4. Replace the Oil Filler Plug and the Weather Cap.

MUELLER® MODERN CENTURION® FIRE HYDRANT

Removing Main Valve From Lower Barrel Flange

CAUTION: Always fill the oil reservoir with the Bonnet installed, the hydrant in its normal upright position, and the main valve fully closed. If the hydrant is filled with lubricant under any other circumstances, excess lubricant can overflow the reservoir and create a pressure lock. This could result in damage to the seals or Bonnet, or prevent proper hydrant operation.



1. Remove Weather Cap, Hold Down Nut, Anti-Friction Washer, and Operating Nut. Lubricate Brass Sleeve and slide over threaded stem end to prevent O-ring damage. Unbolt and remove Housing. Remove Safety Flange Bolts and Safety Flange.



2. Remove Upper Barrel. Remove Upper Stem and Stem Coupling from Lower Stem. Slide slotted end of Wrench over Lower Stem. Align holes in Wrench and Stem and attach Wrench to Stem with a Clevis Pin. Lower Support Arm onto the flange of Lower Barrel and tighten Thumb Screw to hold Main Valve in the closed position. Shut off water at the Gate Valve.

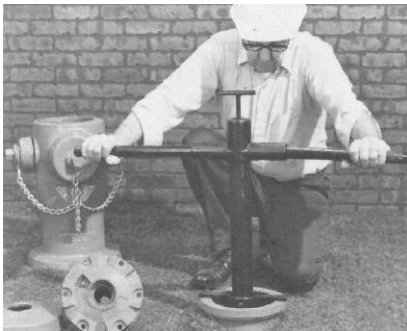

3. Remove Main Valve assembly by turning Wrench counter-clockwise and lift out Wrench, Lower Stem, Main Valve Assembly and Seat Ring from Hydrant Barrel as a unit.

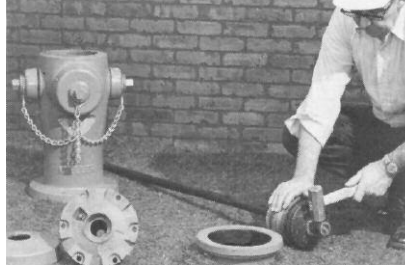

4. Straighten Stainless Steel Lock Washer, unscrew Cap Nut and remove Washer, Stem Seal, Lower Valve Plate, Main Valve and Seat Ring. (On hydrants 1997 and newer, Main Valve can be reversed to provide new seal.) Clean, inspect and replace any damaged parts. Replace Drain Valve Facings. Inspect and lubricate Top and Bottom Seat O-rings (replace if necessary). Lubricate all threaded surfaces and reassemble. With Cap Nut tightened, bend edges of Stainless Steel Lock Washer over one flat on the Lower Valve Plate and one flat on the Cap Nut.



5. Lower Main Valve assembly and carefully thread Seat Ring into the base of the Hydrant hand tight. Raise the Main Valve leaving about 1/2" of play between the Main Valve and Seat. Lower Support Arm onto flange of Lower Barrel and tighten Thumb Screw.



6. Tighten Main Valve to 200 ft-lbs. Turn on water at the Gate Valve and remove Wrench from Stem by removing Clevis Pin.



7. Reassemble Upper Stem to Lower Stem. Place Upper Barrel in place and reassemble Safety Flange.



8. Attach the Brass Sleeve to Upper Stem and lubricate outside to protect O-ring Seals from thread damage. Bolt the Housing to Upper Barrel. Remove Brass Sleeve; reassemble Operating Nut, Anti-Friction Washer, and Hold Down Nut.* Be sure O-ring Seals are in good condition at thread shoulder on outside of Hold Down Nut and on inside where contact is made with Operating Nut. Remove Oil Filler Plug in Housing. Pour MUELLER Hydrant Lubricant into Oil Reservoir until it is level with Oil Filler Plug hole. Replace Oil Filler Plug and attach Weather Cap.



9. Unscrew one Hose Nozzle Cap slightly to bleed air. Open Hydrant fully. Tighten Hose Nozzle Cap when water starts flowing and check all gaskets for leaks. Turn Operating Nut to fully closed position and remove Hose Nozzle Cap to allow Barrel to drain. Replace Hose Nozzle Cap.

10. Turn Operating Nut in the closing direction to assure Main Valve is closed tightly, then turn in opening direction 1/4 turn to relieve tension on operating mechanism.

***Tighten Hold Down Nut to 200-300 ft-lbs of torque. If torque wrench is not available, use a 3 lb. hammer to strike the end of the A-311 wrench firmly two times to assure the nut is properly tightened.**

MUELLER® MODERN CENTURION® FIRE HYDRANT

Removing Main Valve From Top of Upper Barrel

CAUTION: Always fill the oil reservoir with the Bonnet installed, the hydrant in its normal upright position, and the main valve fully closed. If the hydrant is filled with lubricant under any other circumstances, excess lubricant can overflow the reservoir and create a pressure lock. This could result in damage to the seals or Bonnet, or prevent proper hydrant operation.



1. Remove Weather Cap, Hold Down Nut, Operating Nut and Anti-Friction Washer. Lubricate Brass Sleeve and slide over threaded stem end to prevent O-ring damage. Unbolt and remove Housing. Remove Brass Sleeve.



2. Slide slotted end of Wrench over top of Stem and engage the slot with Pin welded to Upper Stem. Tighten "T" handle of Wrench firmly. Lower support arm onto top of Upper Barrel and tighten Thumb Screw to hold the Main Valve in the closed position. Shut off water at the Gate Valve. Remove Main Valve assembly by turning Seat Wrench counter-clockwise.



3. Lift out Wrench, Upper and Lower Stem, Main Valve Assembly and Seat Ring from Hydrant Barrel as a unit.



4. Straighten Stainless Steel Lock Washer, unscrew Cap Nut and remove Washer, Stem Seal, Lower Valve Plate, Main Valve and Seat Ring. Clean, inspect and replace any damaged parts. (On hydrants 1997 and newer, Main Valve can be reversed to provide new seal.) Replace Drain Valve Facings. Inspect and lubricate Top and Bottom Seat O-rings (replace if necessary). Lubricate all threaded surfaces and reassemble.

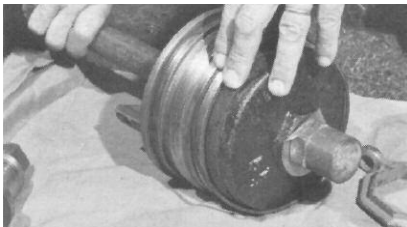

5. With Cap Nut tightened to 100 ft-lbs on 5 1/4" Hydrant or 50 ft-lbs on 4 1/2" Hydrant, bend edges of Stainless Steel Lock Washer over one flat on the Lower Valve Plate and one flat on the Cap Nut.



6. Lower Main Valve into the Barrel, turn Seat Wrench clockwise, and carefully thread Main Valve and Seat Ring into the base of the Hydrant hand tight. Raise the Main Valve leaving about 1/2" of play between the Main Valve and Seat. Lower Support Arm and tighten Thumb Screw.

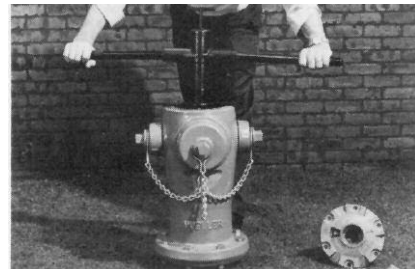

7. Turn Seat Wrench clockwise to tighten Main Valve to 200 ft-lbs. Turn on water at the Gate Valve and remove Seat Wrench by loosening "T" Handle.



8. Attach the Brass Sleeve to Upper Stem and lubricate outside to protect O-ring Seals from thread damage. Place Housing onto Upper Barrel and tighten Bolts. Remove Brass Sleeve. Reassemble Operating Nut, Anti-Friction Washer, and Hold Down Nut. * Be sure O-ring Seals are in good condition at thread shoulder on outside of Hold Down Nut and on inside where contact is made with Operating Nut. Remove Oil Filler Plug in Housing. Pour MUELLER Hydrant Lubricant into Oil Reservoir until it is level with Oil Filler Plug hole. Replace Oil Filler Plug. Screw on Weather Cap.



9. Unscrew one Hose Nozzle Cap slightly to bleed air. Open Hydrant fully. Tighten Hose Nozzle Cap when water starts flowing and check all Gaskets for leaks. Turn Operating Nut to fully closed position and remove Hose Nozzle Cap to allow Barrel to drain. Replace Hose Nozzle Cap.

10. Turn Operating Nut in the closing direction to assure Main Valve is closed tightly, then turn in opening direction 1/4 turn to relieve tension on operating mechanism.

***Tighten Hold Down Nut to 200-300 ft-lbs of torque. If torque wrench is not available, use a 3 lb. hammer to strike the end of the A-311 wrench firmly two times to assure the nut is properly tightened.**

MUELLER® MODERN CENTURION® FIRE HYDRANT

Facing of Hose Nozzles



1. Loosen Nuts on Safety Flange Bolts.



3. Rotate upper barrel section as desired.



5. Tighten Safety Flange Bolts.



2. Turn Operating Nut slightly in the opening direction to relieve compression between barrel sections.



4. Tighten Operating Nut, turning in closing direction.

6. Turn Operating Nut in the closing direction to assure Main Valve is closed tightly, then turn in opening direction 1/4 turn to relieve tension on operating mechanism.

MUELLER® MODERN CENTURION® FIRE HYDRANT

Inserting Extension Section

CAUTION: Always fill the oil reservoir with the Bonnet installed, the hydrant in its normal upright position, and the main valve fully closed. If the hydrant is filled with lubricant under any other circumstances, excess lubricant can overflow the reservoir and create a pressure lock. This could result in damage to the seals or Bonnet, or prevent proper hydrant operation.



1. Remove the Weather Cap, Hold Down Nut, Anti-Friction Washer and Operating Nut from the Hydrant. Lubricate outside of Brass Sleeve and slide over threaded stem to prevent O-ring damage. Unbolt and remove the Housing. Remove Brass Sleeve.



2. Unbolt and remove Safety Flange.



3. Remove the Upper Barrel and remove Stem and Safety Stem Coupling by removing the lower Stainless Steel Cotter Pin and Clevis Pin.



4. Place Extension Stem and Extension Coupling on Lower Stem and retain it with Stainless Steel Clevis Pin and Cotter Pin.



5. Attach Extension Barrel to Lower Barrel with solid Flange halves (without groove) and Bolts, being sure Flange Gasket is in place.



6. Assemble Upper Stem and Safety Stem Coupling onto Extension Stem and retain it with Stainless Steel Clevis Pin and Cotter Pin. **MAKE SURE SAFETY STEM COUPLING IS INSTALLED WITH NOTCHES TOWARDS THE LOWER STEM. WORDS "THIS END UP" TOWARDS THE UPPER STEM.**



7. Attach Upper Barrel to Extension Barrel with Safety Flange halves (with bevel on outer edge downward) and Bolts, being sure Safety Flange Gasket is in place.



8. Attach Brass Sleeve to Upper Stem and lubricate outside to protect O-ring seals from thread damage. Bolt Housing onto Upper Barrel and remove the Brass Sleeve. Reassemble Operating Nut, Anti-Friction Washer and Hold Down Nut* Be Sure O-ring seals are in good condition at thread shoulder on outside of Hold Down Nut and on inside where contact is made with Operating Nut. Remove Oil Filler Plug and pour MUELLER Hydrant Lubricant into Oil Reservoir until it is level with Oil Filler Plug hole. Replace Oil Filler Plug and Weather Cap.

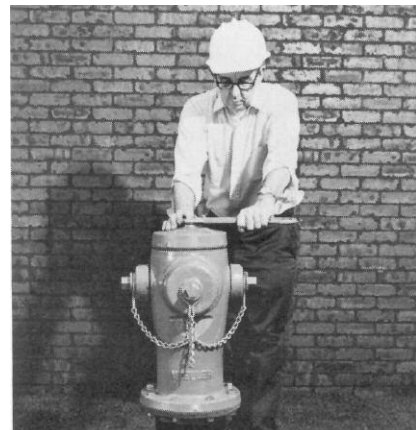

9. Unscrew one Hose Nozzle Cap slightly to bleed air. Open Hydrant fully. Tighten the Hose Nozzle Cap when water starts flowing and check all gaskets for leaks. Turn Operating Nut to fully CLOSED position and remove Hose Nozzle Cap to allow Barrel to drain. Replace Hose Nozzle Cap.

10. Turn Operating Nut in the closing direction to assure Main Valve is closed tightly, then turn in opening direction 1/4 turn to relieve tension on operating mechanism.

***Tighten Hold Down Nut to 200-300 ft-lbs of torque. If torque wrench is not available, use a 3 lb. hammer to strike the end of the A-311 wrench firmly two times to assure the nut is properly tightened.**

MUELLER® MODERN CENTURION® FIRE HYDRANT

Replacing Safety Flange and Safety Stem Coupling

CAUTION: Always fill the oil reservoir with the Bonnet installed, the hydrant in its normal upright position, and the main valve fully closed. If the hydrant is filled with lubricant under any other circumstances, excess lubricant can overflow the reservoir and create a pressure lock. This could result in damage to the seals or Bonnet, or prevent proper hydrant operation.



1. Mueller Hydrant with Upper Barrel knocked over by vehicle. **Note:** broken pieces of Safety Flange lying on ground.

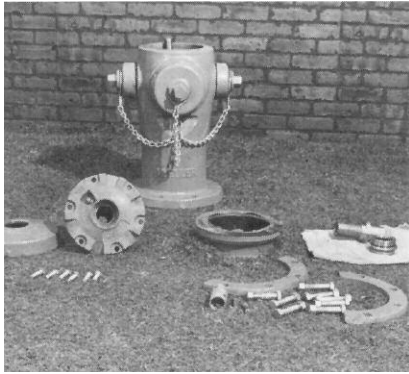

2. Remove Stainless Steel Cotter Pin from Stainless Steel Clevis Pin. Remove the Clevis Pin and damaged Safety Stem Coupling from Upper Stem. Unbolt and remove broken Safety Flange from Upper Barrel. Remove Weather Cap, Hold Down Nut, Anti-Friction Washer and Operating Nut from Upper Barrel. Lubricate Brass Sleeve and slide over threaded Stem end to prevent O-ring damage. Unbolt and remove Housing. Remove Upper Stem from Housing.



3. Remove Stainless Steel Cotter Pin from Stainless Steel Clevis Pin in Lower Stem and throw these pieces away.



4. Assemble new Safety Stem Coupling to Upper Stem with new Stainless Steel Clevis Pin and Cotter Pin. Safety Stem Coupling should be installed with notches towards the Lower Stem. **NOTE:** "THIS END UP" stamped on Coupling.

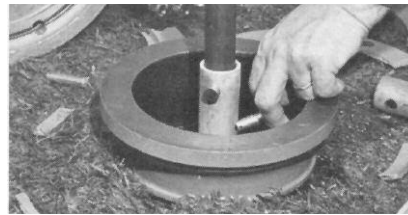

5. Assemble Upper Stem and new Safety Stem Coupling onto Lower Stem and retain with new Stainless Steel Clevis Pin and new Cotter Pin furnished with Safety Stem Coupling.



6. Place Flange Gasket on exposed Flange of Lower Barrel. Place Upper Barrel carefully in position on Lower Barrel. Be sure that it is concentric with Lower Barrel and that Gasket is centered. Bolt into place the two halves of Safety Flange (with bevel on outer edge downward) and with Safety Flange snugly fitting around Lower Barrel.



7. Attach the Brass Sleeve to Upper Stem and lubricate outside to protect O-rings from thread damage. Place Housing onto Upper Barrel and tighten Bolts. Remove Brass Sleeve, reassemble Operating Nut, Anti-Friction Washer and Hold Down Nut.* Be sure O-ring Seals are in good condition at thread shoulder on outside of Hold Down Nut and on inside where contact is made with Operating Nut.



8. Remove the Oil Filler Plug in Housing. Pour MUELLER Hydrant Lubricating Oil into oil reservoir until it is level with Oil Filler Plug hole. Replace Oil Filler Plug and Weather Cap.

9. Unscrew one Hose Nozzle Cap slightly to bleed air. Open Hydrant fully. Tighten the Hose Nozzle Cap when water starts flowing and check all gaskets for leaks. Turn Operating Nut to fully closed position and remove Hose Nozzle Cap to allow Barrel to drain. Replace Hose Nozzle Cap.

10. Turn Operating Nut in the closing direction to assure Main Valve is closed tightly, then turn in opening direction 1/4 turn to relieve tension on operating mechanism.

***Tighten Hold Down Nut to 200-300 ft-lbs of torque. If torque wrench is not available, use a 3 lb. hammer to strike the end of the A-311 wrench firmly two times to assure the nut is properly tightened.**

Mueller Co.