

Installation Instructions

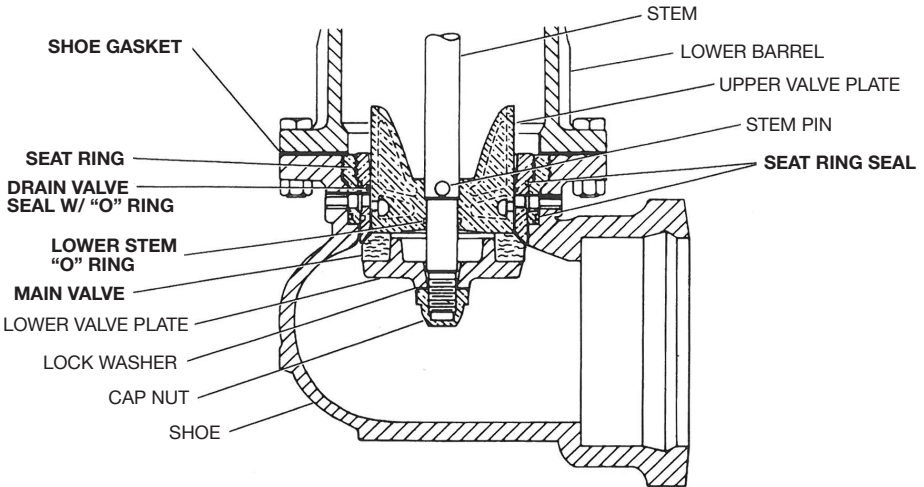

Bold items are included in kit.

CAUTION: In order to properly identify the various "O" rings and gaskets included in this kit, carefully observe the locations and relative sizes of "O" rings and gaskets as you remove parts from the hydrant. As old "O" rings and gaskets are removed, match them up with the new ones by comparing sizes.

1. With Main Valve Assembly removed from hydrant, straighten edge of Lock Washer and remove Cap Nut.
2. Remove Lock Washer and flatten. Retain for later use.
3. Remove Lower Valve Plate and Main Valve.
4. Remove Seat Ring.
5. Remove Upper Valve Plate from Stem by driving out Stem Pin. (Retain pin for reassembly.)
6. Clean the faces of the Upper Valve Plate wings.
7. Replace Lower Stem "O" Ring on inside of Upper Valve Plate. Repin plate to Stem.
8. Install new Seat Ring Seals (2) on new Seat Ring.
9. Push an "O" Ring into the Drain Valve Seals. Insert these assemblies into the grooves in the Seat Ring with the Drain Valve Seal faces showing ("O" Rings concealed).
10. Lightly lubricate wings on Upper Valve Plate and slide new Seat Ring into place, taking care that the Drain Valve Seals remain in their grooves.
11. Install new Main Valve.
12. Install Lower Valve Plate, Lock Washer and Cap Nut. Tighten Cap Nut firmly.
13. Bend edges of Lock Washer over one flat of Cap Nut and one flat of Lower Valve Plate.
14. If Shoe Gasket is to be replaced: remove Lower Barrel and old Shoe Gasket, clean flange faces on Lower Barrel and Shoe, replace gasket and Lower Barrel. (Check gasket for leaks before reburying hydrant and after hydrant is fully reassembled.)
15. Lubricate threads and seals on Seat Ring and reinstall Main Valve Assembly.

Phone: (800) 423-1323

By deviating from the above listed instructions, you will void any product warranty and release Mueller Co. and its affiliated entities from any and all liability associated with the installation or use of this product. For details on the product's warranty, terms, and conditions, please visit www.muellercompany.com.

© 2016 Mueller Co., LLC. All rights reserved.

Form 11094 08/16