

Installation Instructions for Tamper-Proof Operating Mechanism

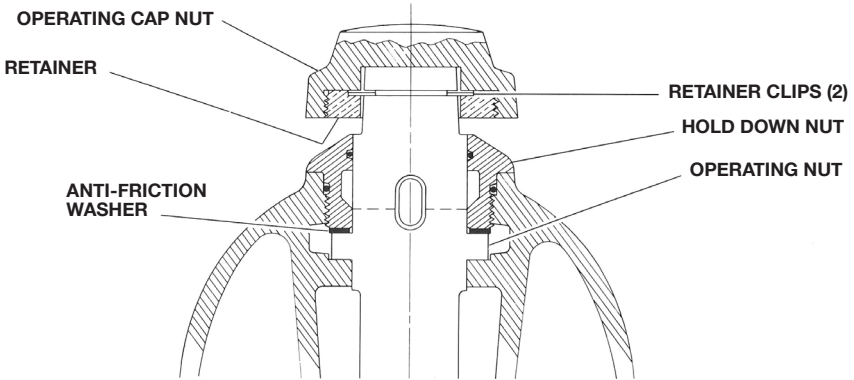

1. Remove Weather Cap from hydrant.
2. Remove Hold Down Nut.
3. Remove Operating Nut along with its Friction Washer.
4. Install new Operating Nut by threading it onto the Stem until it is snugly in place.
5. Install new Anti-Friction Washer.
6. Install new Hold Down Nut using special tool (Catalog No. A391). Tighten to 250 ft. lbs.
7. Place Retainer (with holes down) over end of Operating Nut and engage holes with special wrench (Catalog No. A384). Use wrench to support the Retainer during steps 8 and 9.
8. Insert two (2) Retainer Clips as shown in photo.

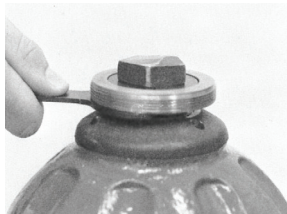
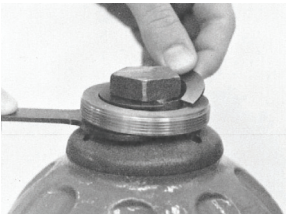

(Installation hint – place Clips in groove of Operating Nut, then raise Retainer to capture Clips in raceway.)



9. Using Wrench (Catalog No. A384) to support Retainer, assemble Operating Nut Cap and tighten counter clockwise to 150 in. lbs.

Installation Instructions for Tamper-Proof Operating Mechanism (continued)

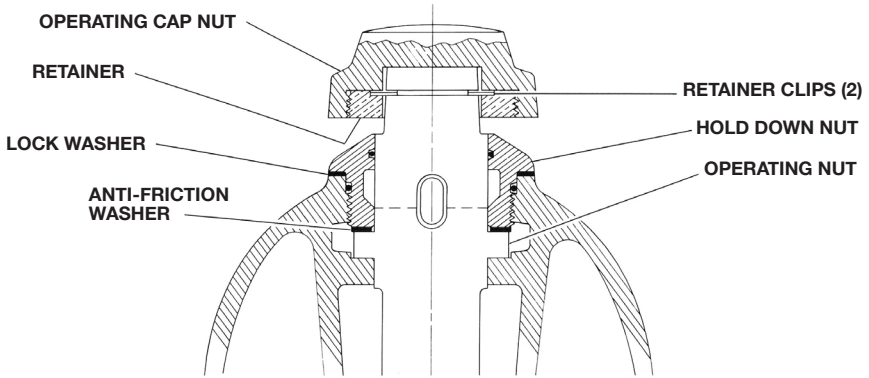

1. Remove Weather Cap from hydrant.
2. Remove Hold Down Nut.
3. Remove "Shakeproof" Lock Washer from either Hold Down Nut or Bonnet.
4. Remove Operating Nut.
5. Install new Operating Nut by threading it onto the Stem until it is snugly in place.
6. Install Anti-Friction Washer (see parts illustration for placement).
7. Place "Shakeproof" Lock Washer on new Hold Down Nut.
8. Install new Hold Down Nut using special tool (Catalog No. A391). Tighten to 250 ft. lbs.
9. Place Retainer (with holes down) over end of Operating Nut and engage holes in bottom of retainer with special wrench (Catalog No. A384). Use wrench to support the Retainer during steps 10 and 11.
10. Insert two (2) Retainer Clips as shown in photo.

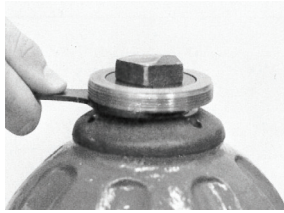
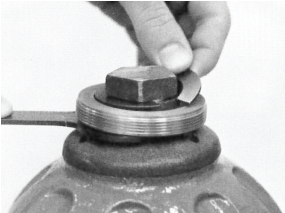

(Installation hint – place Clips in groove of Operating Nut, then raise Retainer to capture Clips in raceway.)



11. Using Wrench (Catalog No. A384) to support Retainer, assemble Operating Nut Cap and tighten counter clockwise to 150 in. lbs.

Phone: (800) 423-1323

By deviating from the above listed instructions, you will void any product warranty and release Mueller Co. and its affiliated entities from any and all liability associated with the installation or use of this product. For details on the product's warranty, terms, and conditions, please visit www.muellercompany.com.

© 2016 Mueller Co., LLC. All rights reserved.

Form 11248 08/16