

MUELLER CANADA

C-20806 C-20807 Adjustable Vertical Indicator Posts

▲ WARNING:

1. Read and follow instructions carefully. Proper training and periodic review regarding the use of this equipment is essential to prevent possible serious injury and/or property damage. The instructions contained herein were developed for using this equipment on fittings of Mueller manufacturer only, and may not be applicable for any other use.
2. DO NOT exceed the pressure ratings of any components or equipment. Exceeding the rated pressure may result in serious injury and/or property damage.
3. Safety goggles and other appropriate protective gear should be used. Failure to do so could result in serious injury.

TABLE OF CONTENTS	PAGE
General Information	2
Technical Data	3
Dimensions	4
Installation	5-6
Parts	7
Maintenance	8

Mueller Canada

Reliable Connections®

Customer Service Center
Barrie, ON
705-719-9965

www.muellercanada.com
more-info@muellercanada.com

C-20806/C-20807 Adjustable Vertical Indicator Posts

General Information

OVERVIEW

Vertical Indicator Posts are designed to operate non-rising stem (inside screw) gate valves, which are used to control an underground water supply to automatic sprinkler, water spray deluge, foam-water deluge, or standpipe fire protection systems. They permit operation of underground valves while providing an above ground visual indication as to whether the valves are open or shut, in addition to a means for locking the valves in a particular position. Indicator posts provide for valve operation from outside of the protected property and, therefore, the opportunity for more prompt valve operation in an emergency situation.

Model C-20806/C-20807 Indicator Posts feature a telescoping Stem that can be adjusted to its final position without field cutting of the Stem. The telescoping Stem also permits: easier setting of the "OPEN" and "SHUT" Target Plates (before the Post is extended to its final position); easier adjustment of the post length during the initial installation; and, ready re-adjustment of the post length, if there is a modification in the location of the final grade.

C-20806 Indicator Posts will accommodate 4" – 14" post indicator valves (PIV) requiring 14 to 43 turns to open and that are listed or approved for fire protection system service. The C-20807 Post will accommodate 16" – 24" post indicator valves requiring 49 to 75 turns to open.

Indicator Posts are provided "Standard Order" for use with left hand opening valves; however, they may be "Special Ordered" for use with right hand opening valves or converted in the field for use with a right hand opening valve by changing the left hand opening Post Head to a right hand opening Post Head.

Indicator Posts accept direct attachment of a 1/2" NPT mounting electric supervisory switching device which can be used by proprietary and central stations to monitor the open position of the Indicator Post. Detailed information on attaching a UL/FM approved Supervisory Control Valve Switch (supplied by customer) is given in the Technical Data section.

Approvals and Standards

Model C-20806/C-20807 Indicator Posts are listed by Underwriters Laboratories Inc. (UL) and Underwriters Laboratories Inc. for use in Canada (C-UL). Model C-20806 Indicator Posts are approved by Factory Mutual Research Corporation.

⚠ WARNING: The Model C-20806/C-20807 Indicator Posts described herein must be installed and maintained in compliance with this document, as well as with the applicable standards of the National Fire Protection Association, in addition to the standards of any other authorities having jurisdiction. Failure to do so may impair the integrity of these devices.

The owner is responsible for maintaining their fire protection system and devices in proper operating condition. The installing contractor or manufacturer should be contacted relative to any questions.

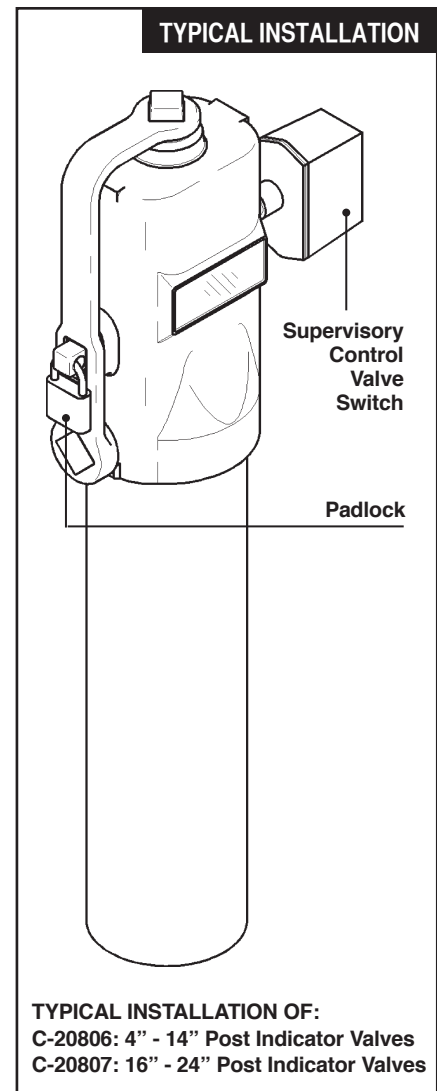

TYPICAL INSTALLATION OF:
C-20806: 4" - 14" Post Indicator Valves
C-20807: 16" - 24" Post Indicator Valves

C-20806/C-20807 Adjustable Vertical Indicator Posts

Technical Data

INDICATOR POSTS

The C-20806/C-20807 Indicator Post bolts directly onto the stuffing box flange of 4" – 24" post indicator valves (PIV) employing 2" operating nuts. The Bell attaches to a PIV mounting flange having four bolt holes spaced at 90° on a 10¹/₂" diameter bolt circle. The Bell has ³/₄" clearance holes for the mounting bolts.

The C-20806 Indicator Post has a Threaded Sleeve which can readily accommodate field positioning of the "OPEN" and "SHUT" Targets for 4" – 14" PIVs requiring 14 to 43 turns to open. The C-20807 has a Threaded Sleeve for 16" – 24" PIVs requiring 49 to 75 turns to open.

The C-20806/C-20807 Indicator Post is available in nine different "Order Lengths." Each "Order Length" provides for adjustment of dimension "D". The Post Head can be adjusted relative to the Lower Barrel by using the two Set Screws located at the base of the Upper Barrel. The Stem requires no field cutting within the indicated adjustment range of each "Order Length."

Nominal trench depths can be accommodated by each "Order Length," for the 4" – 24" Mueller® Resilient Wedge PIVs based on the typical diameter of underground pipe. For PIVs with different 'B' dimensions, the minimum and maximum trench depths which will be accommodated by each "Order Length" can also be calculated (see tables on page 4).

"Standard Order" Posts are factory set with the "OPEN" and "SHUT" Targets positioned for use with left hand (**counter-clockwise**) opening valves. An arrow on the Post Head indicates the left hand direction of opening. The position of the Targets may be reversed in the field, in order to accommodate a right hand opening valve, provided that the Post Head is changed to one indicating right hand opening.

The Post Head, Bell, and Coupling are ASTM A126 Class B gray iron. The Cap is polypropylene; Operating Nut and C-20806 Wrench are ASTM A536 ductile iron. The Windows are made from polycarbonate. The Lower Barrel is ASTM A746 ductile iron. The Upper Barrel, Upper Stem,

Lower Stem, and C-20807 Wrench are carbon steel. The Targets for both posts are Nylon. The C-20806 Threaded Sleeve is Nylon; the C-20807 Threaded Sleeve is Aluminum. The Post Head, Upper Barrel, and Wrench are painted red.

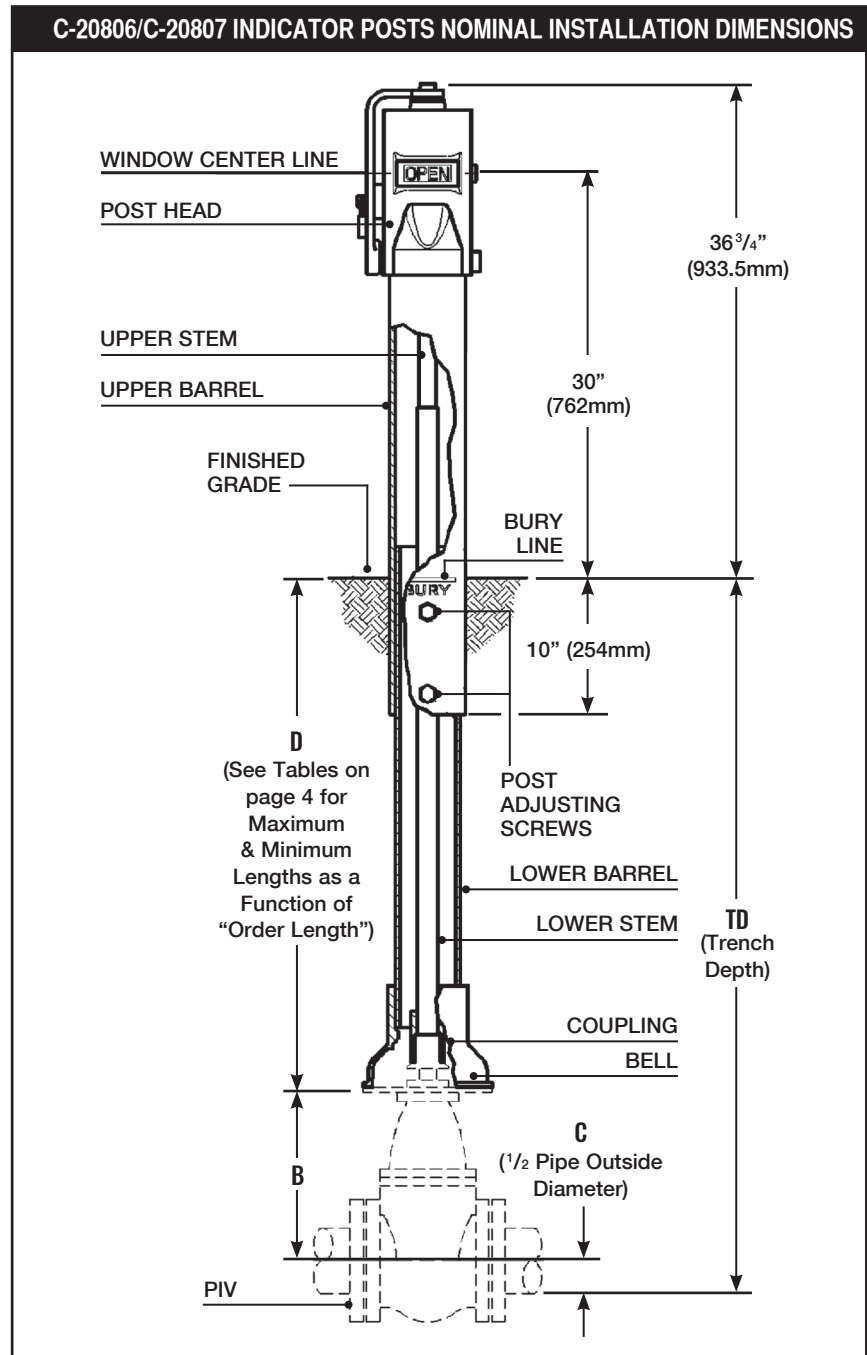

C-20806/C-20807 Adjustable Vertical Indicator Posts

Dimensions

ORDER LENGTH AND TRENCH DEPTH

Order Length Determination

To determine which "Order Length" is necessary (i.e., "A", "B", "C", "D", "E", "F", "G", "H" or "I") for a given trench depth, first calculate dimension 'D' as follows, then select the appropriate "Order Length" from Table 2 that will best accommodate the minimum required length 'D'.

$$'D' (\text{req'd}) = 'TD' - 'B' - 'C'$$

Refer to tables below for nominal trench depths when using Mueller Valves.

TABLE 1. Dimension B & C*

Valve Size	B	C	Turns to Open
4"	10.95"	2.40"	14
6"	14.91"	3.45"	20 ^{1/2}
8"	18.02"	4.53"	26 ^{1/2}
10"	21.62"	5.55"	33
12"	24.52"	6.60"	38 ^{1/2}
14"	29.13"	7.65"	43 ^{1/2}
16"	32.35"	8.70"	49
18"	38.35"	9.75"	57
20"	41.48"	10.80"	63
24"	47.94"	12.90"	75

*C – 1/2 of Pipe Outside diameter (typical for underground pipe)

TABLE 2. Dimension D Adjustment Range

Order Length	Minimum	Maximum
A	22.25"	44.25"
B	41.00"	65.25"
C	62.00"	86.25"
D	83.00"	107.25"
E	104.00"	125.25"
F	125.00"	149.25"
G	151.00"	175.25"
H	171.00"	195.25"
I	191.00"	215.25"

Minimum and Maximum Trench Depth Determination

The minimum and maximum trench depths which will be accommodated by a specific "Order Length" can be calculated as follows by using the minimum and maximum 'D' dimensions shown above.

$$'TD'(\text{min.}) = 'D' (\text{min.}) + 'B' + 'C'$$

$$'TD'(\text{max.}) = 'D' (\text{max.}) + 'B' + 'C'$$

MUELLER C-20806 NOMINAL TRENCH DEPTHS

Valve Size	ORDER LENGTH																	
	A		B		C		D		E		F		G		H		I	
	Min.	Max.	Min.	Max.	Min.	Max.	Min.	Max.	Min.	Max.	Min.	Max.	Min.	Max.	Min.	Max.	Min.	Max.
4"	3'-0"	4'-10"	4'-6"	6'-7"	6'-3"	8'-4"	8'-0"	10'-1"	9'-9"	11'-7"	11'-6"	13'-7"	13'-8"	15'-9"	15'-4"	17'-5"	17'-0"	19'-1"
6"	3'-5"	5'-3"	4'-11"	7'-0"	6'-8"	8'-9"	8'-5"	10'-6"	10'-2"	12'-0"	11'-11"	14'-0"	14'-1"	16'-2"	15'-9"	17'-10"	17'-5"	19'-6"
8"	3'-9"	5'-7"	5'-4"	7'-4"	7'-1"	9'-1"	8'-10"	10'-10"	10'-7"	12'-4"	12'-4"	14'-4"	14'-6"	16'-6"	16'-4"	18'-2"	17'-10"	19'-10"
10"	4'-1"	5'-11"	5'-8"	7'-8"	7'-5"	9'-5"	9'-2"	11'-2"	10'-11"	12'-8"	12'-8"	14'-8"	14'-10"	16'-10"	16'-8"	18'-6"	18'-2"	20'-2"
12"	4'-5"	6'-3"	6'-0"	8'-0"	7'-9"	9'-9"	9'-6"	11'-6"	11'-3"	13'-0"	13'-0"	15'-0"	15'-2"	17'-2"	17'-0"	18'-10"	18'-6"	20'-6"
14"	4'-11"	6'-9"	6'-6"	8'-6"	8'-3"	10'-3"	10'-0"	12'-0"	11'-9"	13'-6"	13'-6"	15'-6"	15'-8"	17'-8"	17'-4"	19'-4"	19'-0"	21'-0"

MUELLER C-20807 NOMINAL TRENCH DEPTHS

Valve Size	ORDER LENGTH																	
	A		B		C		D		E		F		G		H		I	
	Min.	Max.	Min.	Max.	Min.	Max.	Min.	Max.	Min.	Max.	Min.	Max.	Min.	Max.	Min.	Max.	Min.	Max.
16"	5'-3"	7'-1"	6'-10"	8'-10"	8'-7"	10'-7"	10'-2"	11'-11"	12'-1"	13'-10"	13'-10"	15'-10"	16'-0"	18'-0"	17'-8"	19'-8"	19'-4"	21'-4"
18"	5'-10"	7'-8"	7'-5"	9'-5"	9'-2"	11'-2"	10'-11"	12'-6"	12'-8"	14'-5"	14'-5"	16'-5"	16'-7"	18'-7"	18'-3"	20'-3"	19'-11"	21'-11"
20"	6'-3"	8'-1"	7'-9"	9'-10"	9'-6"	11'-7"	11'-3"	12'-11"	13'-0"	14'-10"	14'-9"	16'-10"	16'-11"	19'-0"	18'-7"	20'-8"	20'-3"	22'-4"
24"	6'-11"	8'-9"	8'-6"	10'-6"	10'-3"	12'-3"	12'-0"	13'-7"	13'-9"	15'-6"	15'-6"	17'-6"	17'-8"	19'-8"	19'-4"	21'-4"	21'-0"	23'-0"

*For non-Mueller valves, see the instruction on page 5.

C-20806/C-20807 Adjustable Vertical Indicator Posts

Installation

INSTALLATION INSTRUCTIONS

Post Targets must be positioned for use with the appropriate number of turns to open the post indicator valve. Improper positioning of the Targets can result in an erroneous indication of the open or shut position of the valve. The C-20806 Indicator Post will accommodate positioning of the Targets to operate PIVs requiring 14 to 43 turns to open; the C-20807 Indicator Post will accommodate positioning the Targets to operate PIVs requiring 49 to 75 turns to open.

NOTE: The Targets for the C-20806 Indicator Post have been factory set for use with a 6" Mueller® PIV and the Targets for the C-20807 Indicator Post have been factory set for a 24" Mueller PIV. Consequently, Steps 6 – 10 need not be performed when installing the C-20806 Post with a 6" Mueller PIV (or with a PIV that requires 20½ turns to open) or the C-20807 Post with a 24" Mueller PIV (or with a PIV that requires 75 turns to open).

Installing the Post

1. Completely close the PIV.
2. Place approximately 5" high blocks onto the stuffing box flange of the installed valve. Set the Indicator Post onto the blocks and generally centered over the PIV operating nut.
3. Slide out the Shipping Disk, and allow the Coupling to drop down over the PIV operating nut. Attach the Coupling to the operating nut with the Cotter Pin.
4. Remove the blocks and lower the Indicator Post onto the PIV stuffing box flange. Bolt the Bell and stuffing box flange together using the four Cap Screws and Nuts. Also at this time make certain that the three Cap Screws securing the Bell to the Lower Barrel are uniformly tightened.

NOTE: If the pipe is sloped, it may be necessary to shim some of the Cap Screws with steel washers, so that the Post will be plumb and the Stem will run true with the center of the Post Head. Coupling clearances can accommodate a maximum pipe slope of 5 degrees.

It is recommended that a spirit level be used to set the vertical alignment of the Indicator Post.

5. Order Lengths "C" – "I," partially backfill the trench to a level 4 feet below the final grade. Backfilling at this point will help maintain vertical alignment of the Indicator Post while completing the installation.

6. Loosen the Set Screw, and lift the Post Head/Upper Stem Assembly just high enough to insert a Phillips head screwdriver through Hole "A" in the Upper Stem. The Phillips head screwdriver will temporarily hold the Post Head above the upper Barrel.
7. Remove the Wrench, pry off the Cap, remove the Retaining Ring, then lift the Post Head clear of the Upper Stem Assembly.
8. Position the Targets (see below).
9. Replace the Post Head, Retaining Ring, and Cap.
10. Remove the Phillips head screwdriver, lower the Post Head, and tighten the Set Screw.

POSITIONING OF TARGETS

FOR LEFT HAND OPENING VALVES

SHUT TARGET:
Top surface of threaded flange aligned with CT (center top) mark OR bottom surface aligned with CB (center bottom) mark (see note 1).

OPEN TARGET:
Top surface of threaded flange aligned with Mueller Valve size mark (10" Valve shown) OR set to Dimension "X" (see note 2).

FOR RIGHT HAND OPENING VALVES

SHUT TARGET:
Top surface of threaded flange aligned with CT (center top) mark OR bottom surface aligned with CB (center bottom) mark (see note 1).

OPEN TARGET:
Top surface of threaded flange aligned with Mueller Valve size mark (10" Valve shown) OR set to Dimension "X" (see note 2).

NOTES:

C-20806 INDICATOR POST

1. Set shut target first.
2. For 16" Mueller valves (prior to 2012) set to dimension 'x' (3.5")
3. For valves manufactured by other than Mueller Co., set to dimension 'X' calculated as follows:

$$'X' \text{ in inches} = \frac{\text{NO. OF TURNS TO OPEN VALVE}}{14}$$

C-20807 INDICATOR POST

1. Set shut target first.
2. For valves manufactured by other than Mueller Co., set to dimension 'X' calculated as follows:

$$'X' \text{ in inches} = \frac{\text{NO. OF TURNS TO OPEN VALVE}}{22}$$

C-20806/C-20807 Adjustable Vertical Indicator Posts

Installation

11. Using the Wrench, open and close the valve and check to see that the “SHUT” and “OPEN” Targets are clearly in view in the Windows, at their respective positions, and that there is no feeling of binding of the Upper or Lower Stem Assemblies. It is recommended that the turns to open/close be counted and compared to the valve manufacturer’s specification, in order to verify full valve opening.

NOTES: If there is any indication of binding of the internal operating parts, the vertical alignment of the Indicator Post must be corrected. If the Target Plates are not properly in view, completely close the PIV, then repeat Steps 6 – 11.

12. Loosen the two Cap Screws at the base of the Upper Barrel, then slide the Post Head up until the Bury Line of the Post Head coincides with the planned finish grade. Tighten the two Set Screws at the base of the Post Head with a torque of 40 to 60 ft-lbs. When properly installed, the center line of the Target Windows will be 30” above the finish grade.

13. Backfill to final grade and repeat Step 11.

14. Tighten the switch mounting hole plug if the Supervisory Control Valve Switch is not to be immediately attached.

15. Install the Supervisory Control Valve Switch (supplied by customer).

- Remove the Cover from the assembly, then loosen the Trip Rod Locking Screw. Adjust the position of the Trip Rod so that it extends about $1\frac{3}{8}$ ” beyond the Nipple, then securely tighten the Trip Rod Locking Screw.
- Rotate the Post Operating Nut until the PIV is fully open. Note the position of one of the “OPEN” Targets in its Window.
- Rotate the Operating Stem until the “OPEN” Targets are out of the Post Windows. Note the direction in which the “OPEN” Target will move when it is returned to the Post Window.

d) Remove the Nipple from the PCVS assembly, then with the Locknut screwed over the Nipple threads, hand tighten the Nipple into the $\frac{1}{2}$ ” NPT hole provided in the Post Head, then tighten the Locknut against the Post Head to secure the Nipple firmly in place.

e) Refer to “Positioning of Targets” (pg. 5) as appropriate, and note the direction in which the Trip Rod must move when the “OPEN” Target is returned to the Post Window. Slide the assembly as far as possible onto the Nipple while maintaining proper orientation of the assembly, then tighten the Set Screw that holds the assembly onto the Nipple.

f) Attach leads from an electrical continuity meter to the appropriate terminals.

g) Return the valve to its fully open position. Verify that the “OPEN” Target returns to the position noted in Step b. Also, verify that the Switch contacts change position within two turns of the valve being fully open.

h) Begin to return the valve to its closed position. Verify that the Switch contacts change back to their original position within two turns from full open.

NOTE: If the Upper Stem Assembly binds before the “OPEN” Target reaches its full open position, or the switch contacts do not change position as described in Steps g and h, then the Targets must be readjusted.

If the Targets require readjustment, close the PIV, remove the Switch assembly, and repeat Steps 6 – 11; however, when positioning the Targets, rotate both Targets at the same time as necessary so that the “OPEN” target will trip the Actuator Rod of the Switch. Repositioning of the “OPEN” and “SHUT” Targets relative to each other should not be necessary. Repeat Steps b – h.

i) Remove the electrical continuity test leads. The external field wiring connections can now be made to the Switch.

NOTE: Use of a weathertight conduit connector with a gasket seal is recommended.

ATTACHMENT OF SUPERVISORY CONTROL VALVE SWITCH

Left-Hand Opening Valves

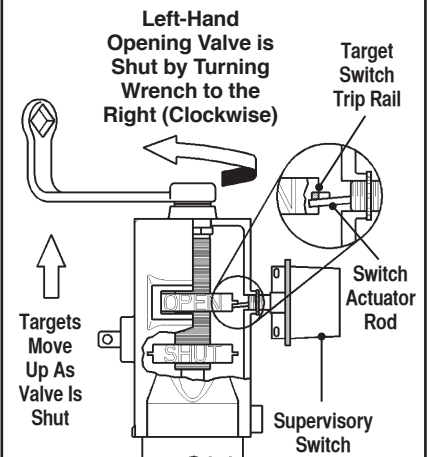

Right-Hand Opening Valves

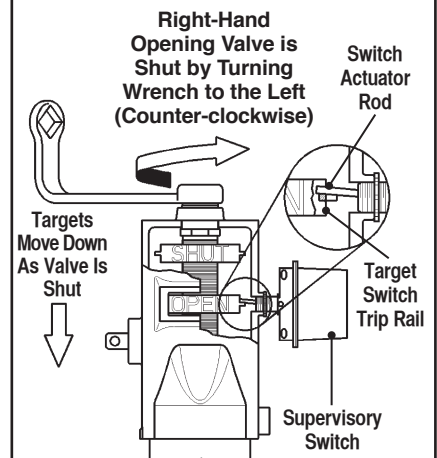

C-20806/C-20807 Adjustable Vertical Indicator Posts

Parts

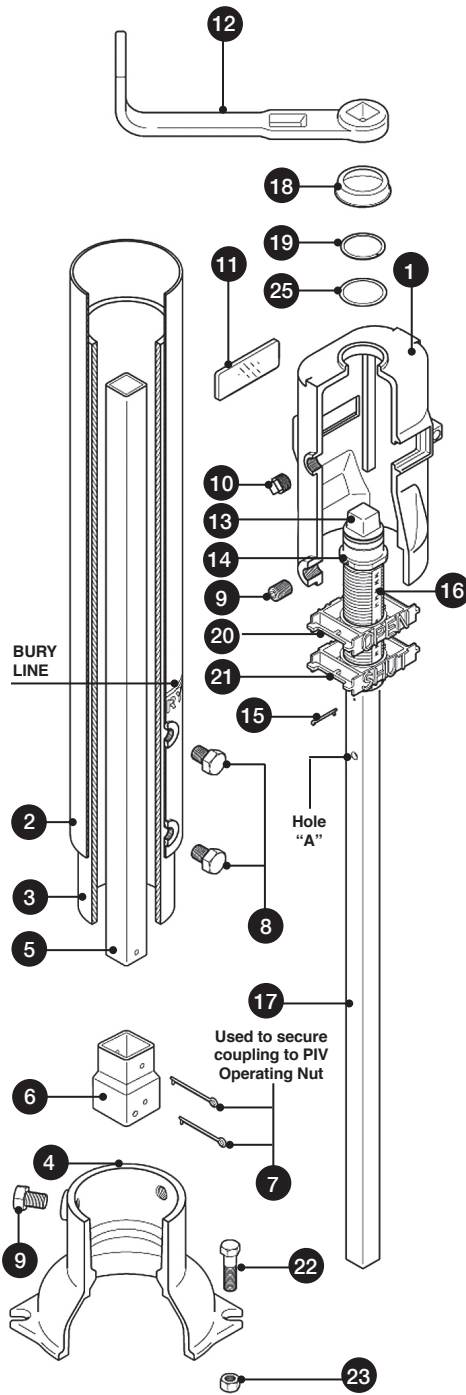

ID	PART NAME
1	Post Head
2	Upper Barrel
3	Lower Barrel
4	Bell
5	Lower Stem
6	Coupling
7	Cotter Pin, 1/4" x 3/4" (2 req'd)
8	Hex Head Cap Screw, 3/4-10UNC x 1" (5 req'd)
9	Hex Socket Set Screw, 3/4-10UNC x 1"
10	Pipe Plug, 1/2" NPT
11	Window (2 req'd)
12	Wrench
13	Operating Nut
14	Spring Pin, 1/8" x 2 1/4"
15	Cotter Pin, 1/4" x 2 1/2"
16	Threaded Sleeve
17	Upper Stem
18	Weather Cap
19	Retaining Ring
20	"OPEN" Target
21	"SHUT" Target
22	Hex Head Cap Screw, 5/8-11UNC x 2 1/4" (4 req'd)
23	Hex Nut, 5/8-11UNC (4 req'd)

NOTE: For models with handwheels, contact customer service for replacement parts.

When ordering Replacement Parts, specify Description and Part No.

REPLACEMENT PARTS

Description & Part No.

1. O.L. Post Head (C-20806)	148692
O.R. Post Head (C-20806)....	148649
O.L. Post Head (C-20807)	241029
O.R. Post Head (C-20807)....	241030
2. Upper Barrel.....	147307
3. Lower Barrel	
"A".....	147308
"B".....	147309
"C".....	147310
"D".....	147311
"E".....	147312
"F".....	147451
4. Bell	148689
5. Lower Stem Assembly	
"A".....	287201
"B".....	287202
"C".....	287203
"D".....	287204
"E".....	287205
"F".....	287206
6. Coupling Insert	290156
7. Long Cotter Pin	198430
8. Hex Head Cap Screw,	
3/4 - 10UNC x 1".....	190560
9. Hex Socket Set Screw,	
3/4 - 10 UNC x 1".....	290634
10. Pipe Plug 1/2" NPT.....	198582
11. Window.....	148790
12. Wrench	
(C-20806).....	148690-1
(C-20807).....	241013
13. Upper Stem Assembly	
(C-20806).....	287079
(C-20807).....	287645
Square Op Nut	
Right.....	149691-1
Left.....	148691-1
14. Spring Pin	190330
15. Short Cotter Pin	198429
16. Threaded Sleeve	
(C-20806).....	148634
(C-20807).....	241011
17. Upper Stem.....	148633
18. Weather Cap.....	290143
19. Retaining Ring	290157
20. OPEN Target	
(C-20806).....	290144
(C-20807).....	290552
21. SHUT Target	
(C-20806).....	290145
(C-20807).....	290553
22. Hex Bolt.....	195040
23. Hex Nut	195048

C-20806/C-20807 Adjustable Vertical Indicator Posts

Maintenance

CARE AND MAINTENANCE

Model C-20806/C-20807 Indicator Posts do not require any regular schedule maintenance.

It is recommended that Indicator Posts used to operate fire protection system water control valves be locked in the fully-open position using the Post Wrench. The locks must be sturdy and resistant to breakage except by heavy bolt cutters.

It is also recommended that once a month a visual inspection procedure be followed, with the following items checked:

1. The Post Head, Upper Barrel, and Windows have not been damaged.
2. The Targets indicate that the valve is open.

3. The Wrench is in place on the Indicator Post, and it is properly locked in the "OPEN" position.

In addition, on a quarterly basis, the Indicator Post should be closed two turns and then reopened tight to verify that the PIV is in the full open position and properly engages with the Post and, that the Supervisory Switch contacts (if applicable) properly change position.

Any damaged parts must be immediately replaced. The Indicator Post should also be physically tried to be sure that the valve is in the fully-open position, if there are any damaged parts, sign of tampering, or the position of the valve is questionable.

NOTE: Before closing a fire protection system main valve for maintenance work on either the Indicator Post or fire protection systems which it controls, permission to shut down the affected fire protection systems must first be obtained from the proper authorities and all personnel who may be affected by this decision must be notified.

It is recommended that fire protection systems be inspected by a qualified Inspection Service.



Water (U.S.)
1.800.423.1323

www.muellercompany.com
moreinfo@muellercompany.com

Water (Canada)
1.705.719.9965

www.muellercanada.com
more-info@muellercanada.com

International
1.423.490.9555

www.mueller-international.com
international@muellercompany.com

Copyright © 2017 Mueller Canada, Ltd. All Rights Reserved.

The trademarks, logos and service marks displayed in this document herein are the property of Mueller Canada, Ltd., its affiliates or other third parties. Products marked with a section symbol (§) are subject to patents or patent applications. For details, visit www.mwppat.com. These products are intended for use in potable water applications. Please contact your Mueller Sales or Customer Service Representative concerning any other application(s).

Form 12111C - 08/17