

H - No. and Size of Holes and Slots Equally Spaced on
 Ø J - Bolt Circle 2 MJ Ends

SECTION A-A - TYPICAL

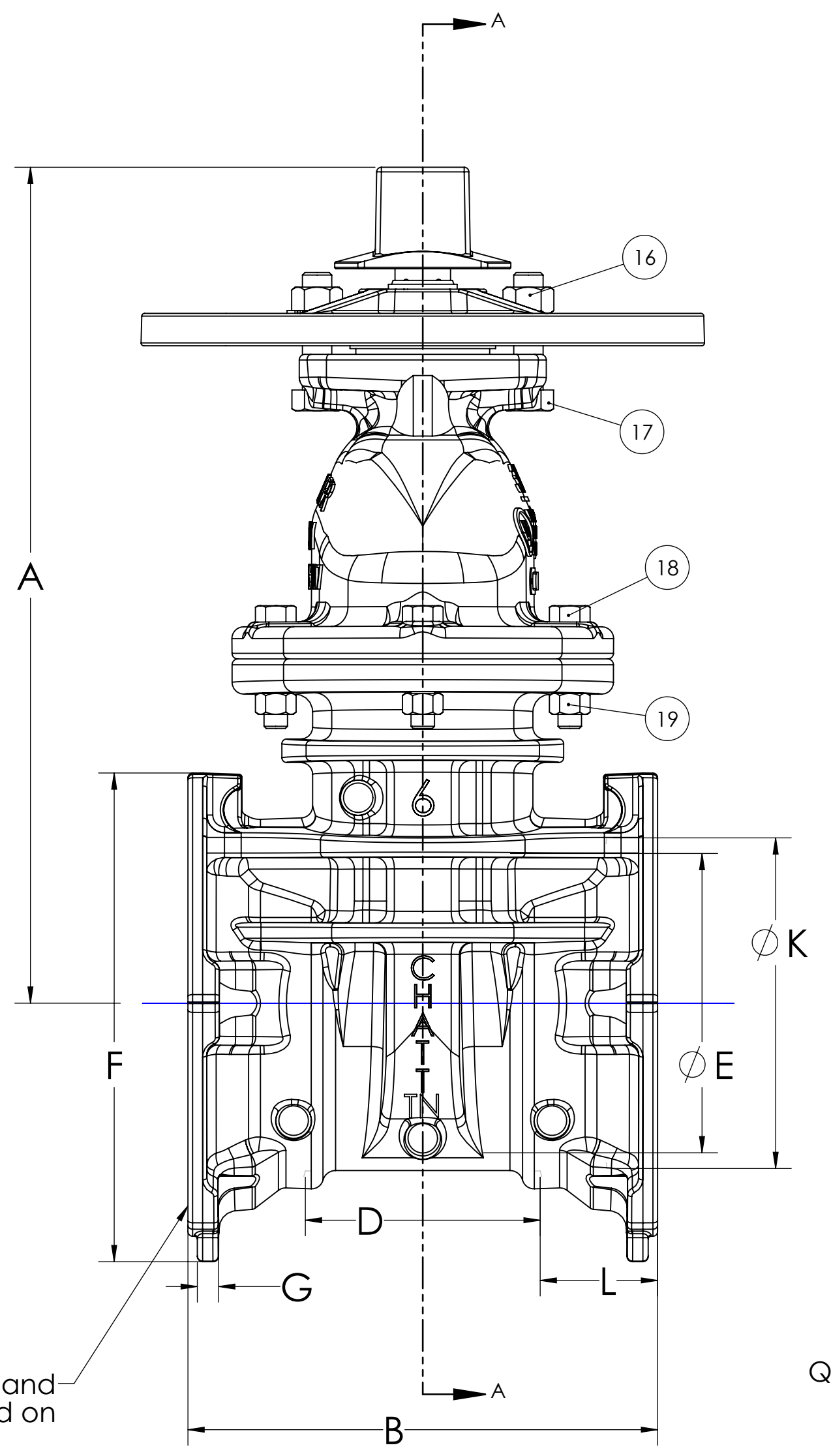

MECH JOINT ENDS - MJ x MJ

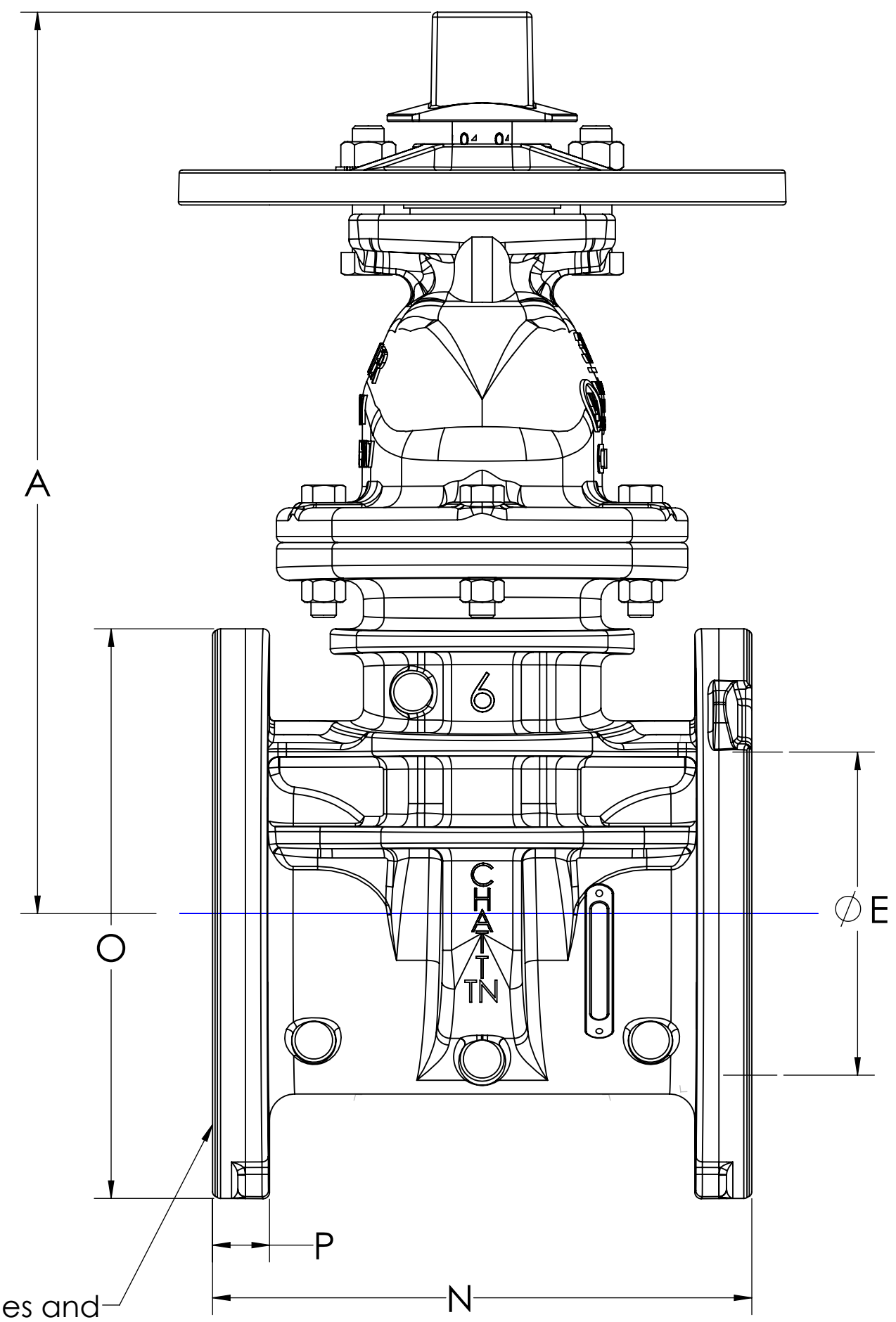

FLANGE ENDS - FL x FL

ITEM NO.	DESCRIPTION	B. QTY.	MATERIAL	ASTM	NOTES
1	Cap Screw	1	316 Stainless Steel	F593	Group 2 - CW
2	Wrench Nut	1	Ductile Iron	A536	
3	PIV Stuffing Box	1	Ductile Iron	A536	
4	Wiper Ring (dirt seal)	1	Thermoplastic Polyurethane	D412/ D624 D2240/ D792	HY-52D
5	Anti-friction Washer	2	Acetal		
6	Stuffing Box O-Ring	1	Nitrile Rubber		R34
7	Bonnet	1	Ductile Iron	A536	
8	Stem O-ring	3	Nitrile Rubber		R34
9	Stem	1	Bronze	‡	See Note
10	Bonnet O-ring	1	Nitrile Rubber		R34
11	Body MJ Ends	1	Ductile Iron	A536	
12	Stem Nut	1	Bronze	B584	C89833 / NSF 372
13	Encapsulated Disc	1	◆	D2000	See Note
14	Disc Casting	1	Ductile Iron	A536	
15	Guide Cap	2	Acetal		
16	Stuffing box nuts	2	316 Stainless Steel	F594	Group 2 - CW
17	Stuffing box bolts	2	316 Stainless Steel	F593	Group 2 - SH
18	Bonnet bolts	"M"	316 Stainless Steel	F593	Group 2 - SH
19	Bonnet nuts	"M"	316 Stainless Steel	F594	Group 2 - CW
20	Body FL Ends		Ductile Iron	A536	

◆ Rubber Encapsulated Ductile Iron Disc
 Ductile Iron - ASTM A536
 Rubber Options
 1. SBR - ASTM D2000
 2. EPDM - ASTM D2000

‡ Bronze Stem Options:
 1. Manganese - ASTM B138
 • Alloy C67600
 2. Everdur - ASTM B98
 • Alloy C66100

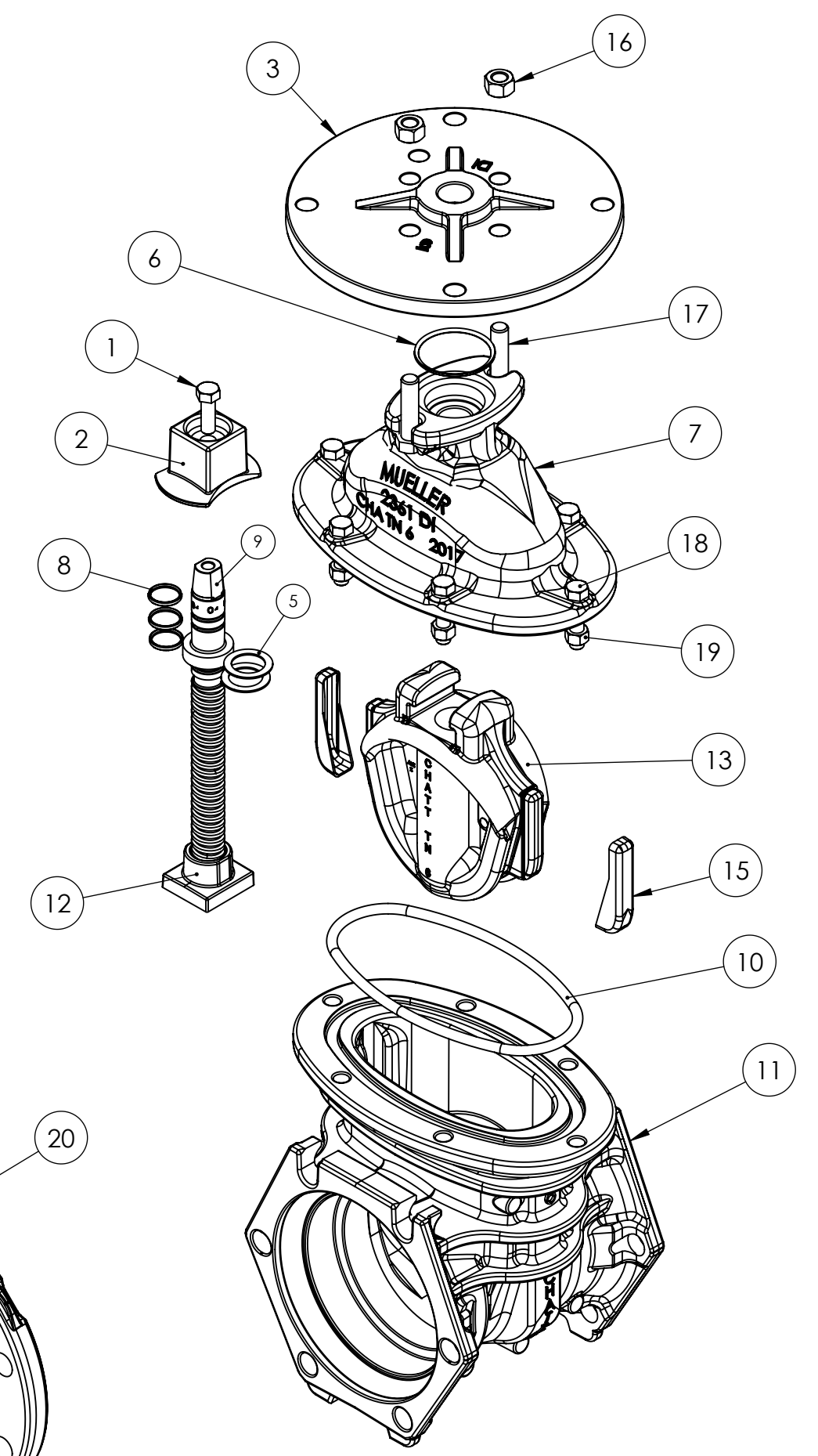

APPROVED
 By Matthew Sliger at 8:47 am, Jun 23, 2017

Valve Size	A	B	C	D	Ø E (Thru Ø)	F	G	H	Ø J (Bolt Circle Ø)	Ø K	L	M	Turns to Open	Weight MJ x MJ	N	O	P	Q	Ø R (Bolt Circle Ø)	Weight FL x FL
4	14.19	9.5	10.79	4.50	4.30	8.40	0.50	4-0.88	7.50	4.90	2.50	4	14	90	9.00	9.00	1.00	8-0.75	7.50	100
6	18.00	10	13.5	5.00	6.30	10.41	0.45	6-0.88	9.50	7.00	2.50	6	20.5	139	10.50	11.25	1.13	8-0.88	9.50	160
8	21.50	10.5	16.36	5.50	8.30	12.68	0.50	6-0.88	11.75	9.15	2.50	6	26.5	196	11.50	13.50	1.15	8-0.88	11.75	223
10	25.50	11.5	20	6.50	10.30	15.24	0.62	8-0.88	14.00	11.20	2.50	8	33	285	13.00	16.00	1.29	12-1.00	14.25	325
12	28.62	12	21	7.00	12.30	18.024	0.62	8-0.88	16.25	13.30	2.50	8	38.5	360	14.00	19.00	1.33	12-1.00	17.00	435

MUELLER CONFIDENTIAL
 TITLE TO AND OWNERSHIP OF THIS ENGINEERING DATA REMAINS IN MUELLER CO. NO USE IS TO BE MADE OF THIS DATA EXCEPT AS SPECIFICALLY AUTHORIZED BY MUELLER CO. ASSENT ON THE PART OF THE RECEIPTS TO THESE CONDITIONS IS PRESUMED.

UNLESS OTHERWISE SPECIFIED: DIMENSIONS ARE IN INCHES TOLERANCES:
 ANGULAR: ±
 TWO DECIMAL: ±
 THREE DECIMAL: ±



MATERIAL SEE TABLE
 FINISH

NAME	DATE
JMH	5/22/2017
AO	
MS	
Q.A.	

DESCR.		SIZE		WEIGHT (lbs): SEE TABLE	
2361 RWGV 350W w/ PIV SBX		D		7414	
DWG. NO.		REV		SCALE:	
7414		0		DO NOT SCALE DRAWING	
SHEET 1 OF 1					