

1-1/2" LOW LEAD METER SETTER			
ITEM	PART NO.	DESCRIPTION	QTY.
1	500B2428601N	1-1/2" LOW LEAD ANGLE BALL VALVE	1
2	500H14244N	1-1/2" LOW LEAD ANGLE CHECK VALVE	1
3	682070E	1-1/2" LOW LEAD RISER SUB ASSEMBLY	1
4	790187E	LOW LEAD TEE 1-1/2" x 1-1/2" x 1" IP	1
5	283236E	1" LOW LEAD BYPASS SUB-ASSEMBLY	1
6	330B25170N	1" LOW LEAD INLINE BALL METER VALVE	1
7	509704E	LOW LEAD TEE 1-1/2" x 1" IP	1
8	282618E	1-1/2" LOW LEAD RISER SUB ASSEMBLY	1

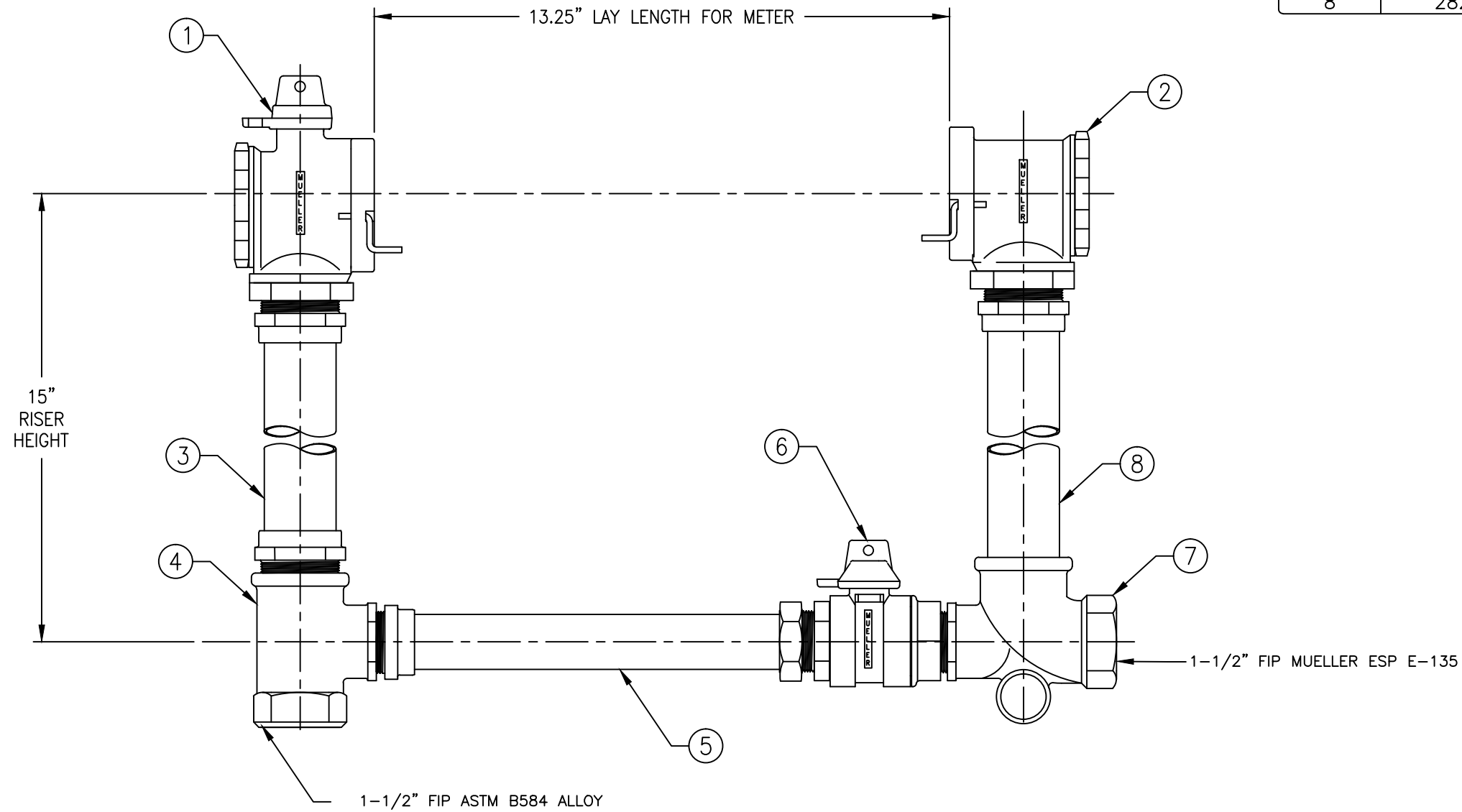

103B2429--2--N

(MILLIMETER) INCH INITIAL RELEASE DRFT'R JCJ 9-8-11 CHK'R APP E.O. NUMBER		TOLERANCES - MACHINING UNLESS OTHERWISE NOTED BREAK EDGES FINISH SURFACES MACH. .006/.016 125 FRACTIONS DECIMALS ANGLES ±1/64 2 PL ±.025 ±1" 3 PL ±.005		THIRD ANGLE PROJECTION PURCH. FINISH REF. NO. SCALE NONE STK. NO.	
		MAT'L. DESCR. 1 1/2" x 18" LOW LEAD COPPER METER YOKES		REVISION NUMBER 103B2429--2--N SHEET 1 OF 1	

ECO: 1571382

REV.	DESCRIPTION	REF.	DRFT'R	CHK'R	APP	DATE