

ITEM NO	PART NUMBER	QTY	DESCRIPTION
1	047139	1	1" X 1-1/2" CLOSED NIPPLE
2	682864	2	
3	330B25170N	1	1" INLINE BALL VALVE (110 X FIP)
4	549750E	2	TEE (2" FIP X 2" SOLDER X 1" FIP)
5	550B2428601N	2	2" FULL PORT BALL VALVE
6	680378E	2	RISER SUB ASSEMBLY
7	682158E	1	BY PASS SUB ASSEMBLY

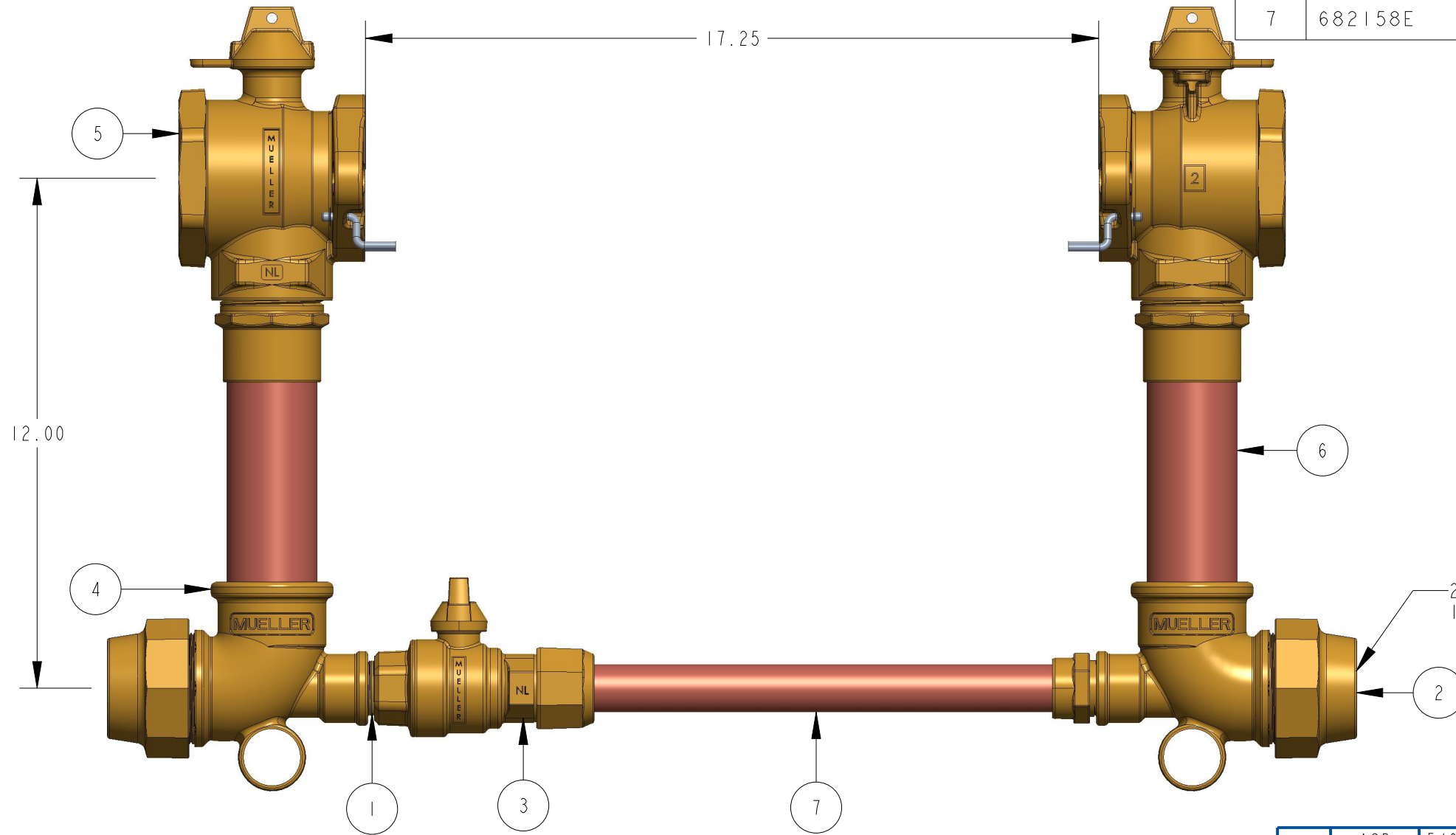

2" GRIP JOINT  
INLET AND OUTLET

OPTION CODE 01:

\*INCLUDES BOTTOM BYPASS LOCKING VALVE

DR. BY	AOD	5/04/22	UNLESS OTHERWISE NOTED		THIRD ANGLE PROJECTION	C.B. NO.
CHKR			BREAK CAST CORNER(S)---			
ENGR			BREAK MACH CORNER(S)---			PURCH.
MGR			TOLERANCES		REF. NO.	PATT. NO.
MFG			UNLESS OTHERWISE NOTED		STK. NO.	
TOOL			LINEAR	ANGULAR	SCALE NONE	
FDRY			±	±		

MAT'L:



DESCR. 2" COPPER METER SETTER  
12" RISER HEIGHT  
LOW LEAD BRASS

NUMBER  
105G2423----01N

105G2423----01N