

ITEM NO	PART NUMBER	QTY	DESCRIPTION
1	509548	2	METER YOKE COUPLING TEE
2	550575	1	1" TOP BY-PASS TUBING
3	550576	1	1" TOP BY-PASS TUBING
4	550579	2	TUBE 2" X 5.438"
5	681558	1	TIE BAR SUB ASSEMBLY
6	074955E	2	1" SPUD
7	330B25146N	1	1" INLINE BALL VALVE W/ 110 COMP. BOTH ENDS
8	330H15428N	1	1" MIP X 1" CTS COMPRESSION TAILPIECE
9	546234E (B)	2	2" PLUGGED TEE (FNPT X SOLDER X 1"FNPT)
10	550B242860IN	2	2" FULL PORT BALL VALVE

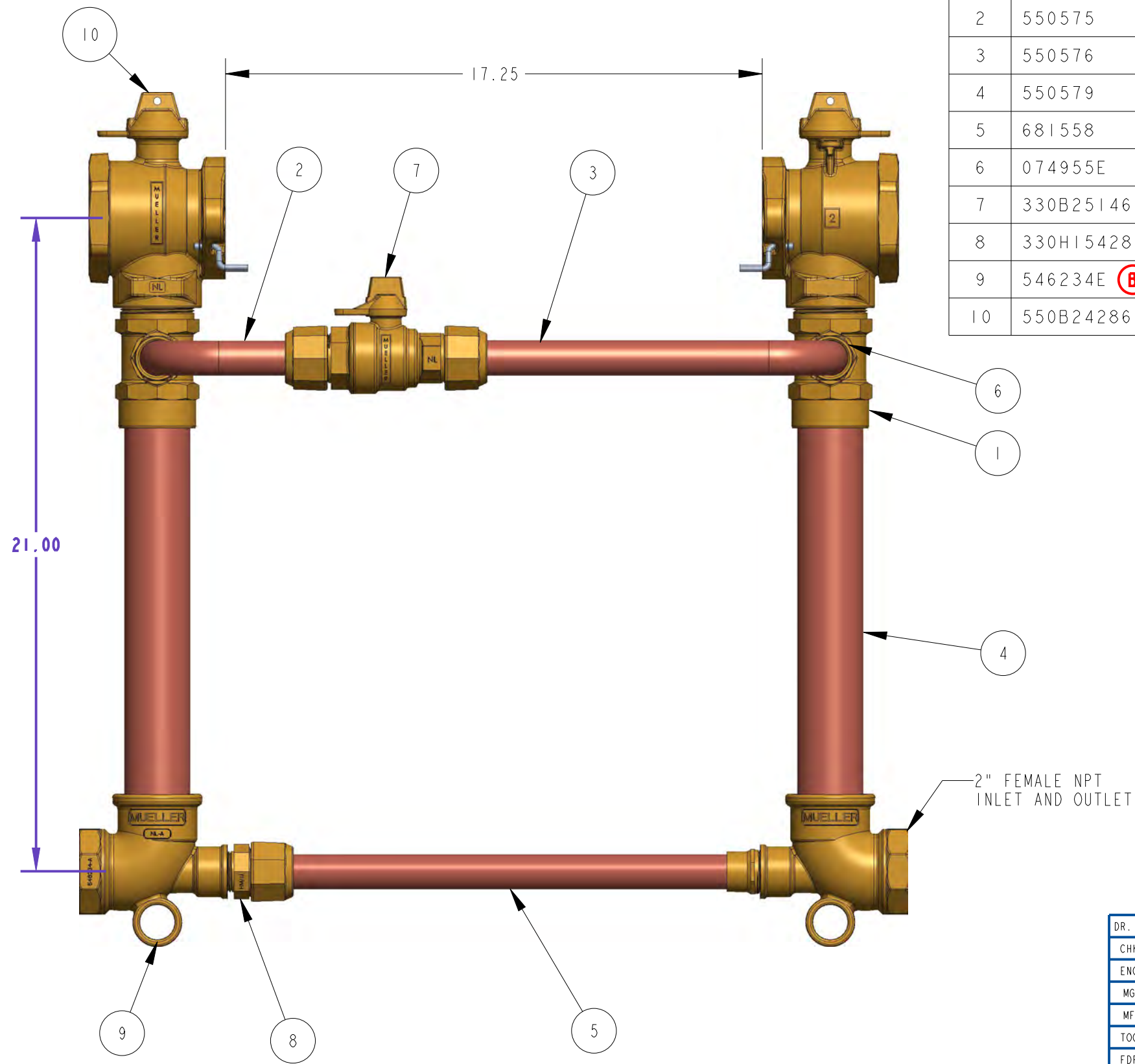

OPTION CODE 107:
 *HIGH BYPASS
 *BALL VALVE SHIFTED TO THE LEFT
 *TEES INSTEAD OF BRAZING JOINT

107B2423----107N

(B)
 546234E WAS
 530146E
 JBK 1/24/23

DR. BY	SLV	2/17/20	UNLESS OTHERWISE NOTED		THIRD ANGLE PROJECTION	C.B. NO.
CHKR			BREAK CAST CORNER(S)---			
ENGR			BREAK MACH CORNER(S)---		PURCH.	PATT. NO.
MGR			TOLERANCES		FINISH	
MFG			UNLESS OTHERWISE NOTED		REF. NO.	SCALE
TOOL			LINEAR	ANGULAR	STK. NO.	NONE
FDRY			±	±		
MAT'L:						
MUELLER			DESCR.	2" COPPER METER SETTER 21" RISER HEIGHT LOW LEAD BRASS	NUMBER	107B2423----107N