

ITEM NO	PART NUMBER	QTY	DESCRIPTION
1	530146	2	TEE (2" FIP X 2" SOLDER X 1" FIP)
2	681558	1	TIE BAR SUB ASSEMBLY
3	330H15428N	1	1" MIP X 1" CTS COMPRESSION TAILPIECE
4	550B2428601N	2	2" FULL PORT BALL VALVE
5	680382E	2	RISER SUB ASSEMBLY

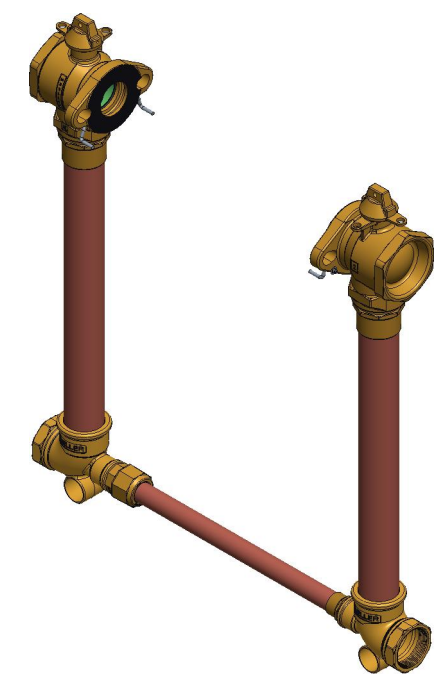
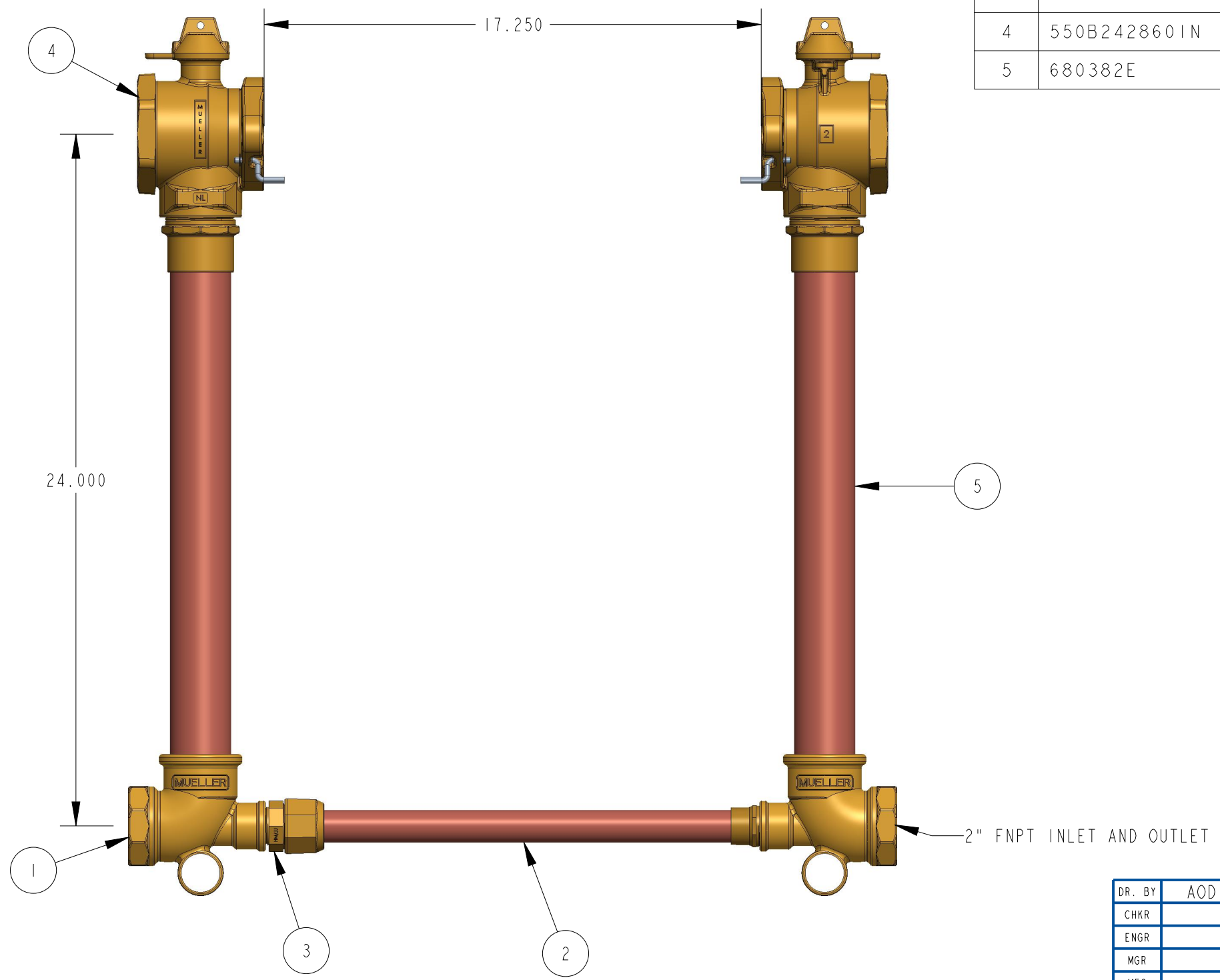

OPTION CODE:
 *BALL VALVE INLET AND OUTLET

108B2422-----00N

DR. BY	AOD	5/5/21	UNLESS OTHERWISE NOTED	THIRD ANGLE PROJECTION	C.B. NO.
CHKR			BREAK CAST CORNER(S)---		
ENGR			BREAK MACH CORNER(S)---	PURCH.	FINISH
MGR			TOLERANCES	REF. NO.	SCALE
MFG			UNLESS OTHERWISE NOTED	STK. NO.	NONE
TOOL			LINEAR		
FDRY			±		
MAT'L:					
			DESCR. 2" COPPER METER SETTER 24" RISER HEIGHT LOW LEAD BRASS	NUMBER 108B2422-----00N	