

ITEM NO	PART NUMBER	QTY	DESCRIPTION
1	507851	2	2" CTS COMPRESSION
2	509702	1	ADAPTER W/ WEB
3	534885	1	COPPER TUBE 1" X 12.50"
4	330H15428N	1	1" MIP X 1" CTS COMPRESSION TAILPIECE
5	549756E	2	TEE (2" CTS COMP X 2" SOLDER X 1" FIP)
6	550B2428601N	2	2" FULL PORT BALL VALVE
7	680383E	2	RISER SUB ASSEMBLY

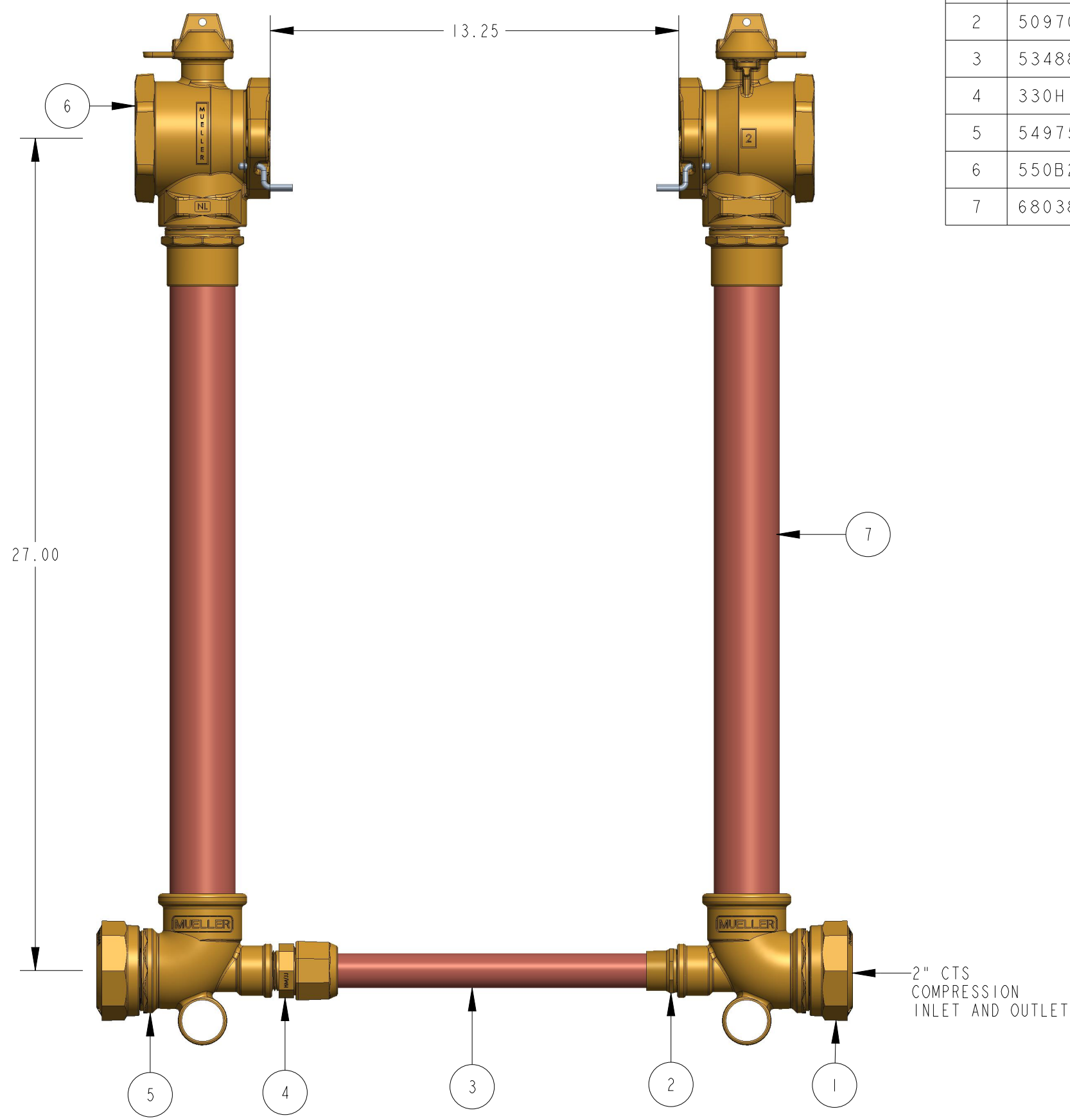

OPTION CODE 05:
 *BALL VALVE ON INLET AND OUTLET
 *13-1/4" LAY LENGTH

DR. BY	AOD	10/26/21	UNLESS OTHERWISE NOTED	THIRD ANGLE PROJECTION	C.B. NO.
CHKR			BREAK CAST CORNER(S)---		
ENGR			BREAK MACH CORNER(S)---	PURCH.	FINISH
MGR			TOLERANCES	REF. NO.	PATT. NO.
MFG			UNLESS OTHERWISE NOTED	SCALE	NONE
TOOL			LINEAR	ANGULAR	STK. NO.
FDRY			±	±	

MAT'L:

MUELLER DESCR. 2" COPPER METER SETTER 27" RISER HEIGHT LOW LEAD BRASS NUMBER 109C2422----05N

109C2422----05N