

**MUELLER**

# LINESEAL<sup>®</sup> BUTTERFLY VALVES

150B, 250B, & 350B Class; Sizes 3" - 48"





# PERFORMANCE IS KEY

Designed specifically for the waterworks industry, Lineal butterfly valves offer the ruggedness and reliability required for buried service and performance. Lower head loss means getting the most from your pumping station dollar. Lower torques mean less costly actuation packages, and the maintenance-free design helps keep your budget under control.

## LINESEAL BUTTERFLY VALVES SIZES 3" - 48"

### LINESEAL 3" - 20" VALVES

Our 3" - 20" valves\* feature a molded-in elastomeric seat which is bonded to the valve body. The bond is tested to ASTM D-429, Method B (minimum 100 lb. pull on 1" strip at 90° angle) to ensure the integrity of the bond. The special configuration of the elastomeric seat resists cold flow and the likelihood of compression set, even when the valve is left in the closed position for extended periods.

The streamlined disc profile reduces turbulence and head loss. 8" - 20" valves are furnished with 316 stainless steel disc edge applied by a non-transferred plasma arc process which provides superior bonding. 3" - 6" valves are furnished with ASTM grade CF8M stainless steel disc.

### LINESEAL 24" AND LARGER VALVES

Our 24" and larger valves\* feature the patented E-LOK® 360° seating system\*\*. The body-mounted elastomeric seat has ridges, which provide multiple sealing lines and permit higher levels of radial compression. As a result, stress in the seat material is reduced, allowing lower seating torques and better sealing action. The seat is mechanically retained in a machined groove by a unique cast epoxy design. Uniform pressure around the entire periphery provides a bubble-tight seal. This design also allows seat adjustment or replacement without removing the valve from the line.

Valves 30" and larger feature a flow-through disc design to provide a greater free-flow area and maintain the higher Cv performance of these larger Mueller valves (e.g. the 24" valve has an offset, slightly concave, solid disc which provides higher Cv performance).

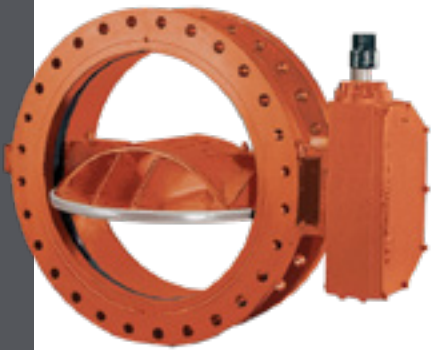
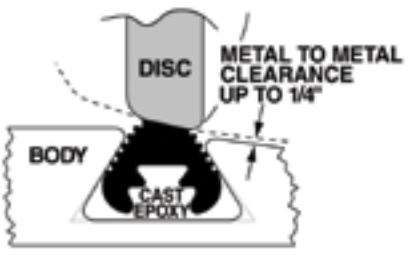

\* Lineal XP and Lineal 350 (size 6" - 20") valves are similar in design to the 24" and larger sizes  
\*\* All sizes of Lineal 350 feature E-LOK seating system

# LINESEAL BUTTERFLY VALVES

Sizes 3" - 48"

## ALL VALVES COMPLY WITH AWWA C504

All Mueller® Lineseal butterfly valves comply with AWWA C504 and are designed for a long service life with little attention or need for maintenance. Stainless steel shafts are corrosion resistant. Chevron V-type packings are used to last the life of the valve without adjustment. These and other features described on the following pages make the Mueller Lineseal the most preferred butterfly valve in the industry.

### PRODUCT LINE OFFERING

	LINESEAL III®	LINESEAL XP11® & LINESEAL XP™	LINESEAL 350®
<b>Class</b>	150B	250B	350B
<b>Sizes</b>	3" - 48"	3" - 48"	6" - 48"
<b>Maximum Working Pressure</b>	150 psig	250 psig	350 psig
<b>Maximum Flow Velocity</b>	16 fps	16 fps	16 fps

### END CONFIGURATIONS AVAILABLE

#### LINESEAL III

CLASS	SIZE	CONFIGURATION
150B	3" - 48"	FL x FL
150B	4" - 48"	MJ x MJ
150B	6" - 36"	FL x MJ
150B	12" & 16"	Slip-on x Slip-on
150B	12" & 16"	Slip-on x FL

#### LINESEAL XP11

CLASS	SIZE	CONFIGURATION
250B	3" - 48"	FL x FL (ANSI Class 125)
250B	4" - 48"	MJ x MJ
250B	6" - 36"	FL (ANSI Class 125) x MJ

#### LINESEAL XP

CLASS	SIZE	CONFIGURATION
250B	3" - 48"	FL x FL (ANSI Class 250)
250B	6" - 48"	MJ x MJ

# 3" - 20" LINESEAL VALVES\*

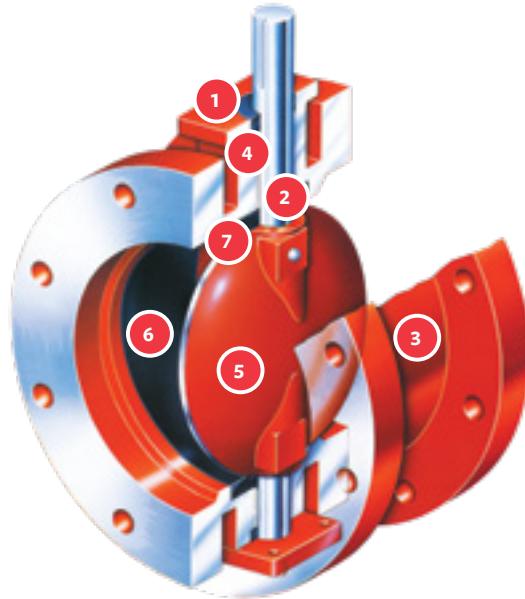

## 1 Chevron V-Type Packing

Self-adjusting, long lasting and should never need replacement because quarter-turn valve operation causes little to no wear. Packing bears on turned, ground and polished stainless steel, reducing wear.

## 2 Corrosion-Resistant Shaft

Constructed of stainless steel (Line Seal III is type 304, Line Seal XP II, Line Seal XP, and Line Seal 350 valves are ASTM A-564 type 630 cond. H-1150). Shaft is one-piece, through-shaft construction sized to meet or exceed requirements of AWWA C504.

## 3 Heavy-Duty Body

Rugged cast iron construction for Line Seal III valves or ductile iron for Line Seal XP II, Line Seal XP, and Line Seal 350 valves. End connections include choice of flanges fully faced and drilled per ANSI B16.1 Class 125 or Class 250, or integrally cast mechanical joint ends. For Line Seal III valves, slip-on ends (for ductile iron and PVC C900 pipe) are also available.

## 4 Self-Lubricating Bearings

Liberally sized, chemically inert nylon bearings are self-lubricating and designed to last the life of the valve.

## 5 Streamlined Disc

Lens-shaped disc is designed to minimize pressure drop and turbulence. Full open valve creates no more friction loss than a 45° elbow. Disc is secured to the shaft by stainless steel pins sized to transmit required torques and withstand stresses imposed under severe operating conditions. Line Seal III disc is cast iron, ASTM A-126 Class B with 316 stainless steel disc edge. Line Seal XP II & Line Seal XP discs are ductile iron ASTM A-536 (65-45-12) with 316 stainless steel disc edge (discs for 3" - 6" Line Seal valves are cast stainless steel, ASTM A-351 CF8M).

## 6 Elastomeric Body Seat

Buna-N seat is bonded to the body\*. The seat cannot be torn from the body under normal pipeline conditions. The precision molding process also ensures that the disc/seat interference cannot cause excessive wear or abrasion during operation.

## 7 Tamper-Proof Disc Centering

Precision molded flats in the bonded seat at the body trunnion mate with machined flats on the disc in the body\*. Positive disc alignment, without play, assures long seat life.

# 24" - 48" LINESEAL VALVES\*

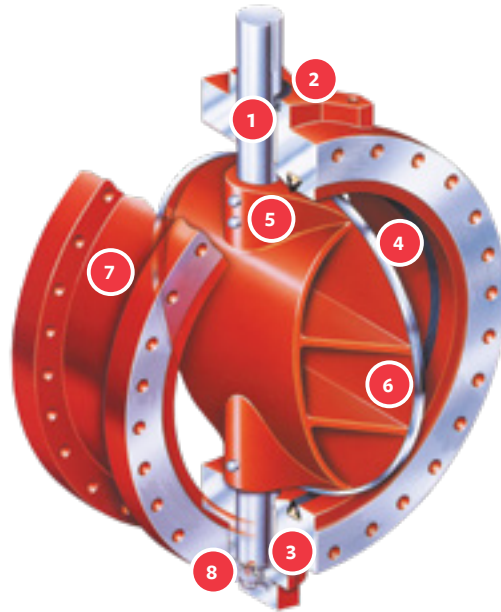

## 1 Corrosion-Resistant Shaft

Constructed of stainless steel (Line seal III is type 304, Line seal XP, Line seal XP, and Line seal 350 valves are ASTM A-564 type 630 cond. H-1150). Two-piece, stub-type shafts are sized per AWWA Standard C504.

## 2 Chevron V-Type Packing

Self-adjusting packing in top trunnion of valve body where shaft protrudes.

## 3 Self-Lubricating Bearings

Sleeve-type bearings are used in both trunnions of the valve body. Teflon lined with special non-metallic backing. Provide electrical insulation between disc and shaft to prevent galvanic corrosion. Low coefficient of friction reduces operating torque requirements.

## 4 Elastomeric Seat

Specially compounded Buna-N seat seals a full 360° against a stainless steel spherical disc edge. Unique grooved-seat design, coupled with the wide spherically shaped seating edge of the disc, allows greater disc closure tolerance (up to 1° off center in closed position without leakage). Seat is mechanically retained in body without metal hardware by a cast epoxy compound that ensures the seat conforms to the precise radius of the disc with uniform contact pressure. It is fully field adjustable and replaceable.

## 5 Strong Shaft Connections

Discs and shafts are connected by tapered stainless steel pins designed to transmit required torques and withstand stresses imposed under severe operating conditions.

## 6 Flow-Through Disc

Provides less pressure drop in full-open position than conventional disc shapes (on 24" size the arch side of the disc is closed and the flat side is open, forming a slightly concave surface\*\*). Disc structure has no internal cores that can shift during casting, no hollow chambers that can collect water, freeze and fracture the disc. Disc edge has stainless steel spherically shaped seating surface. Ductile iron ASTM A-536 (65-45-12) used for Line seal III, Line seal XP, Line seal XP, and Line seal 350 valves.

## 7 Heavy-Duty Body

Rugged cast iron ASTM-126 Class B construction for Line seal III valves, or ductile iron ASTM A-536 (65-45-12) for Line seal XP, Line seal XP, and Line seal 350 valves. End connections include choice of flanges fully faced and drilled per ANSI B16.1 Class 125 or Class 250, or integrally cast mechanical joint ends. For Line seal III valves, slip-on ends (for ductile iron and PVC C900 pipe) are also available.

## 8 Preset Thrust Bearing Assembly

Two-way bearing is preset at factory. On valves 30" and larger, assembly consists of stainless steel stud fastened to the bottom of the valve shaft. Stud extends beyond the bottom cover. Thrust collar is threaded to the collar and pinned. On 24" size, thrust collar is pinned to shaft and adjustment provided by bronze spacers. Thrust collar cavity is packed with grease and fully gasketed to prevent leakage.

\*Contact your Mueller sales representative for valve sizes larger than 48". E-LOK seat design also applies to 6" - 20" Line seal XP valves and all sizes of Line seal 350 valves

\*\*Also 6" - 20" Line seal XP valves

# BURIED SERVICE ACTUATORS

Built Extra Strong and Water Tight for Years of Trouble-Free Service

- 1 Housing**  
Provides structural support plus protection for internal operating mechanism. Mounts to valve trunnion with four bolts. Gasket between housing and cover prevents infiltration of dirt and moisture.
- 2 Screw Rod**  
Precision machined, high strength steel. Transmits input torque to drive mechanism.
- 3 Stop Limiting Collars**  
Built-in, threaded into position, and pinned. Meets or exceeds AWWA C504 Standard for input torque requirements to eliminate the possibility of damage to actuator housing, mechanism, or disc-shaft assembly.
- 4 Lever**  
Rugged casting built to transmit torque from slider nut to valve shaft. On link-lever design, takes up higher portion of nut movement at the “closing” end of the screw, providing a mechanical advantage at the point of highest valve torque.
- 5 Key**  
Actuator is keyed to valve shaft for positive connection.
- 6 Slide Nut**  
Precision machined to mate precisely with screw rod and lever. Capable of withstanding 450 ft. lb. input torque against stop collar.
- 7 Dual Link Construction**  
One link above the screw (shown) and one below (hidden), adds strength and prevents misalignment and jamming of the slider nut.

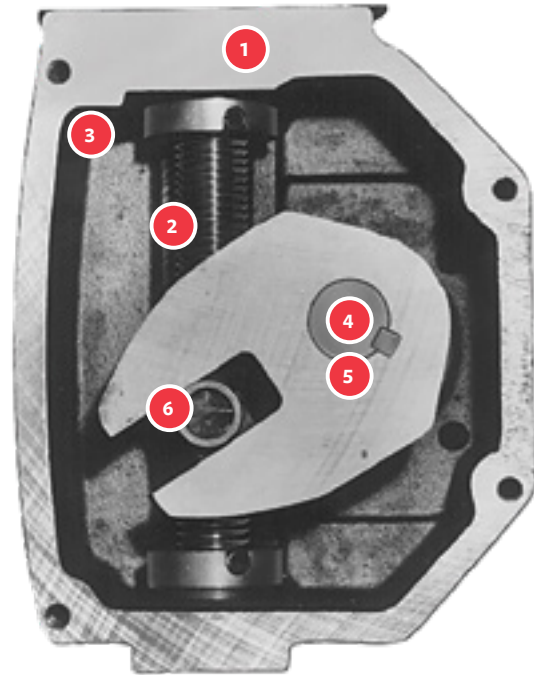

SLOTTED-LEVER ACTUATOR

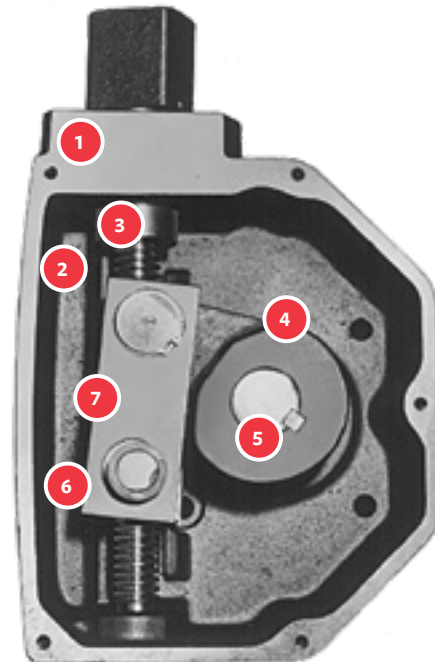

LINK-LEVER ACTUATOR

**SLOTTED-LEVER ACTUATOR**

MTD-2S

**LINK-LEVER ACTUATOR**

MTD-3S

MTD-4S

MTD-5

MTD-5S

MTD-6S

# GROUND LEVEL POSITION INDICATOR

## Diviner® Ground Level Position Indicator

A useful accessory that identifies valve position at a glance, direction, and number of turns to open or close completely. This durable indicator is designed for simple operation, strength and reliability. All working parts are constructed of non-metallic material that is virtually indestructible in this kind of service. Weatherproof, the internal gearing is protected from the elements with a clear, tough plastic cover.

The Diviner position indicator is shipped for field assembly complete with cast iron adapter (1) and cap screws, guide bushings (2), position indicator (3), flexible washer (4), and a 2" square AWWA nut (5) with set screw. The adapter fits a standard 5¼" valve box (6)\* or 5" cast iron soil pipe bell (7)\* utilizing a cast valve box cover with skirt depth of 1" or less. Extension stems (8) are available in 5' and 10' lengths and can be ordered separately at extra cost.

The device is designed for use with valves requiring 250 turns or less.

\* Furnished by others



TYPICAL APPLICATION  
IN 5" SOILPIPE

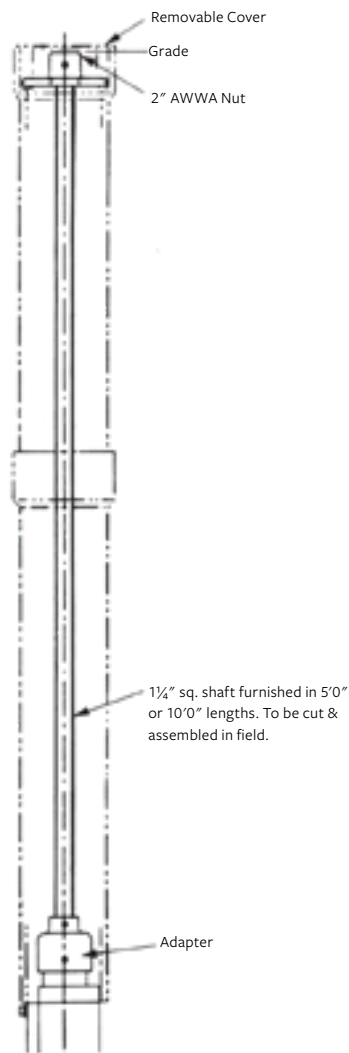
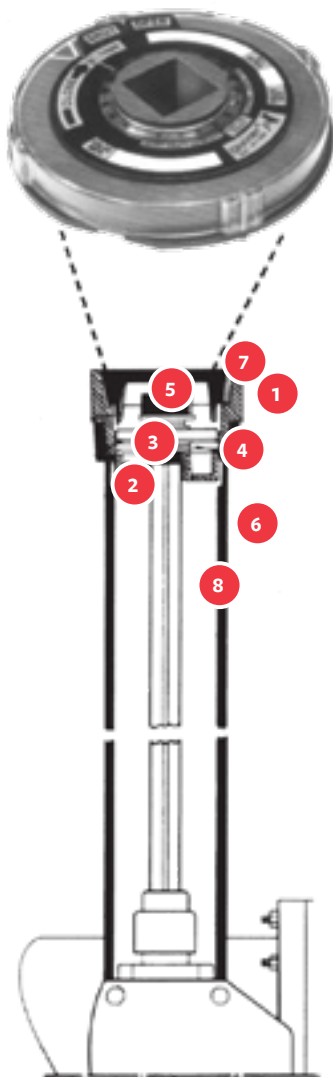

## OUR PRODUCTS

Mueller has built its reputation on producing innovative water distribution products of superior quality – a reputation that is literally “on the line” every day throughout the world. Mueller products and those of its affiliates are used throughout the water system from the source to the consumer. We are committed to continuing research and development of new products and services to meet the growing needs of the water infrastructure industry. Mueller is the largest and only full-line supplier of potable water distribution products in North America and its markets continue to expand globally.

## OUR PEOPLE

The capacity to deliver the widest array of products and stand behind those products to ensure your satisfaction is our strength. The success of Mueller is dependent upon the success of those who are involved, both inside and outside our company. Therefore, we feel our future is wholly dependent on long-term relationships with our employees, customers and suppliers. This is why we strive to be proactive and responsive to their needs, always looking for a “better way”. It’s an approach that has set us apart since 1857 and will assure our mutual achievement and prosperity in the future.

## OTHER INNOVATIVE MUELLER PRODUCTS

### SUPER CENTURION® 350™ HYDRANT



- 350 psig (2400 kPa/24 barg) working pressure, 700 psig (4800 kPa/48 barg) test pressure
- Sealed oil reservoir with automatic pressure lubrication
- Entire hydrant - epoxy coating inside and out inhibits corrosion
- Convenient, reversible main valve doubles service life
- Efficient hydraulic design provides maximum flow
- Certified to ANSI/NSF 61, ANSI/NSF 37210-year limited warranty

**For more information about Mueller or to view our full line of water products, please visit [www.muellerwp.com](http://www.muellerwp.com) or call Mueller customer service at 1.800.423.1323.**

Mueller refers to one or more of Mueller Water Products, Inc. a Delaware corporation (“MWP”), and its subsidiaries. MWP and each of its subsidiaries are legally separate and independent entities when providing products and services. MWP does not provide products or services to third parties. MWP and each of its subsidiaries are liable only for their own acts and omissions and not those of each other. MWP brands include Mueller®, Echologics®, Hydro Gate®, Hydro-Guard®, Jones®, Krausz®, Mi.Net®, Milliken®, Pratt®, Pratt Industrial®, Singer®, and U.S. Pipe Valve & Hydrant. Please see [muellerwp.com/brands](http://muellerwp.com/brands) to learn more.

© 2020 Mueller Water Products, Inc. All Rights Reserved. The trademarks, logos and service marks displayed in this document are the property of Mueller Water Products, Inc., its affiliates or other third parties. Products above marked with a section symbol (§) are subject to patents or patent applications. For details visit [www.mwppat.com](http://www.mwppat.com).