



Line Seal[®] Butterfly Valves

150B, 250B, & 350B Class; Sizes 3"-48"

Mueller Co.

Reliable Connections[™]

Mueller® Lineseal® Butterfly Valves

Sizes 3"-48"

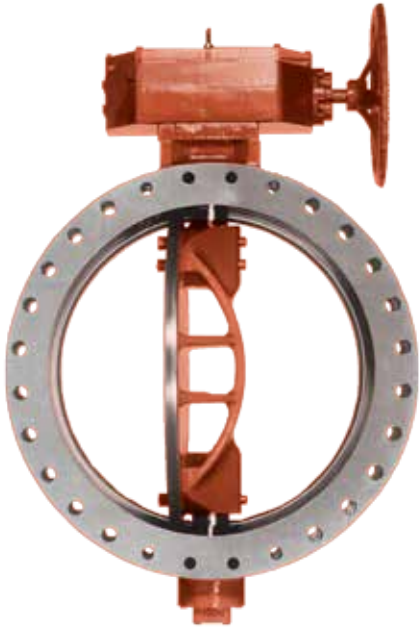
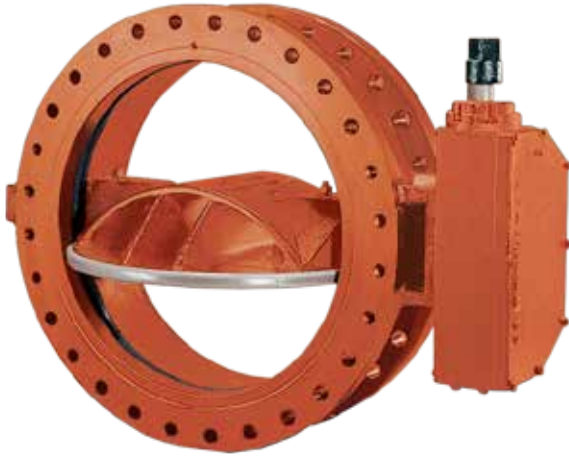

Performance is key.

Designed specifically for the waterworks industry, Lineseal butterfly valves offer the ruggedness and reliability required for buried service and performance. Lower head loss means getting the most from your pumping station dollar. Lower torques mean less costly actuation packages, and the maintenance-free design helps keep your budget under control.

Lineseal 3"-20" valves

Our 3"-30" valves* feature a molded-in elastomeric seat which is bonded to the valve body. The bond is tested to ASTM D-429, Method B (minimum 100 lb. pull on 1" strip at 90° angle) to endure the integrity of the bond. The special configuration of the elastomeric seat resists cold flow and the likelihood of compression set, even when the valve is left in the closed position for extended periods.

The streamlined disc profile reduces turbulence and head loss. The 316 stainless steel disc edge is applied by a non-transferred plasma arc process which provides superior bonding.

Lineseal 24" and larger valves

Our 24" and larger valves* feature the patented E-LOK® 360° seating system**. The body-mounted elastomeric seat has ridges, which provide multiple sealing lines and permit higher levels of radial compression. As a result, stress in the seat material is reduced, allowing lower seating torques and better sealing action. The seat is mechanically retained in a machined groove by a unique cast epoxy design. Uniform pressure around the entire periphery provides a bubble-tight seal. This design also allows seat adjustment or replacement without removing the valve from the line.

Valves 30" and larger feature a flow-through disc design to provide a greater free-flow area and maintain the higher Cv performance of these larger Mueller valves (e.g. the 24" valve has an offset, slightly concave, solid disc which provides higher Cv performance).

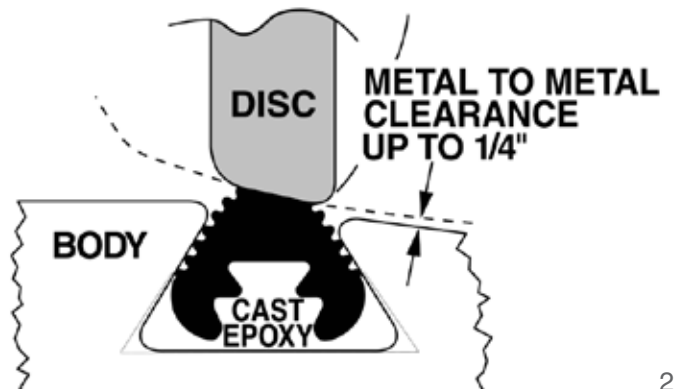

* Lineseal XP 6"-20" valves are similar in design to the 24" and larger sizes.

** All sizes of Lineseal 350 feature E-LOK seating system.

All valves comply with AWWA C504.

All Mueller® Lineseal butterfly valves comply with AWWA C504 and are designed for a long service life with little attention or need for maintenance. Stainless steel shafts are corrosion resistant. Chevron V-type packings are used to last the life of the valve without adjustment. These and other features described on the following pages make the Mueller Lineseal the most preferred butterfly valve in the industry.

Product Line Offering

	Lineseal III®	Lineseal XPII® & Lineseal XP™	Lineseal 350™
Class	150B	250B	350B
Sizes	3"-48"	3"-48"	6"-48"
Maximum working pressure	150psig	250psig	350psig
Maximum flow velocity	16 fps	16 fps	16 fps

End Configurations Available

Lineseal III		
Class	Size	Configuration
150B	3"-48"	FL x FL
150B	4"-48"	MJ x MJ
150B	6"-36"	FL x MJ
150B	12" & 16"	Slip-on x Slip-on
150B	12" & 16"	Slip-on x FL

Lineseal XPII		
Class	Size	Configuration
250B	3"-48"	FL x FL (ANSI Class 125)
250B	4"-48"	MJ x MJ
250B	6"-36"	FL (ANSI Class 125) x MJ

Lineseal XP		
Class	Size	Configuration
250B	3"-48"	FL x FL (ANSI Class 250)

Lineseal 350		
Class	Size	Configuration
350B	6"-48"	FL x FL
350B	6"-36"	MJ x MJ

3"-20" Lineseal® Valves*

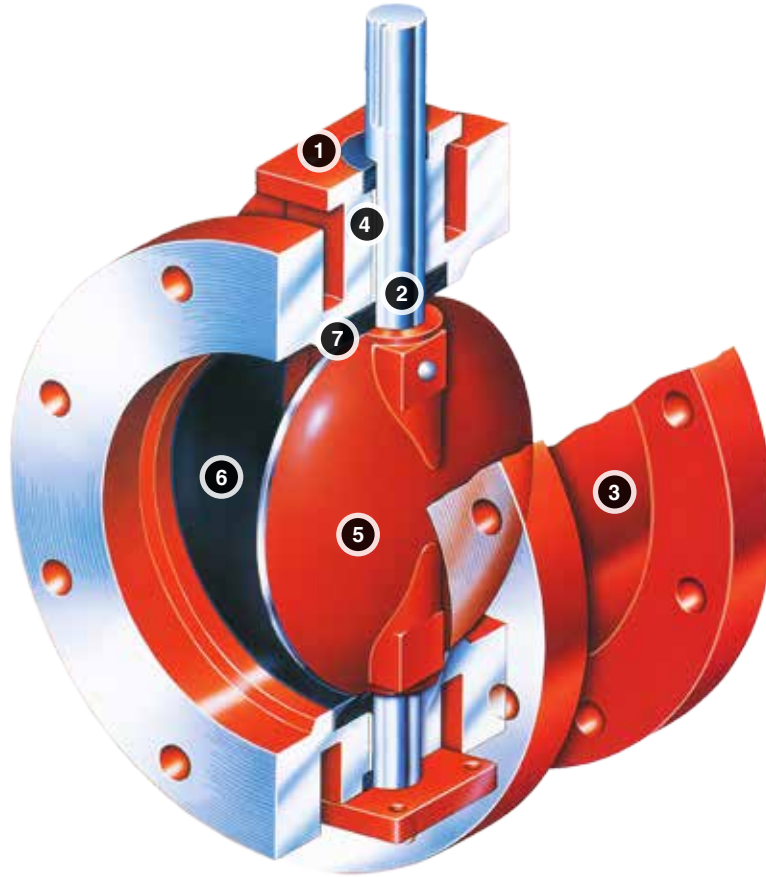

1 Chevron V-Type Packing

Self-adjusting, long lasting and should never need replacement because quarter-turn valve operation causes little to no wear. Packing bears on turned, ground and polished stainless steel, reducing wear.

2 Corrosion-Resistant Shaft

Constructed of stainless steel (Lineseal III® is type 304, Lineseal XP II®, Lineseal XP™, and Lineseal 350™ valves are ASTM A-564 type 630 cond. H-1150). Shaft is one-piece, through-shaft construction sized to meet or exceed requirements of AWWA C504.

3 Heavy-Duty Body

Rugged cast iron construction for Lineseal III valves or ductile iron for Lineseal XP II, Lineseal XP, and Lineseal 350 valves. End connections include choice of flanges fully faced and drilled per ANSI B16.1 Class 125 or Class 250, or integrally cast mechanical joint ends. For Lineseal III valves, slip-on ends (for ductile iron and PVC C900 pipe) are also available.

4 Self-Lubricating Bearings

Liberal sized, chemically inert nylon bearings are self-lubricating and designed to last the life of the valve.

5 Streamlined Disc

Lens-shaped disc is designed to minimize pressure drop and turbulence. Full open valve creates no more friction loss than a 45° elbow. Disc is secured to the shaft by stainless steel pins sized to transmit required torques and withstand stresses imposed under sever operating conditions. Lineseal III disc is cast iron, ASTM A-126 Class B with 316 stainless steel disc edge. Lineseal XP II & Lineseal XP discs are ductile iron ASTM A-536 (65-45-12) with 316 stainless steel disc edge (discs for 3" & 4" Lineseal valves are cast stainless steel, ASTM A-351 CF8M).

6 Elastomeric Body Seat

Buna N seat is bonded to the body*. The seat cannot be torn from the body under normal pipeline conditions. The precision molding process also ensures that the disc/seat interference cannot cause excessive wear or abrasion during operation.

7 Tamperproof Disc Centering

Precision molded flats in the bonded seat at the body trunnion mate with machined flats on the disc in the body*. Positive disc alignment, without play, assures long seat life.

* For Lineseal XP valves, applies to 3" & 4" sizes only. All other sizes have E-LOK® style seat.

24"-48" Lineaseal® Valves*

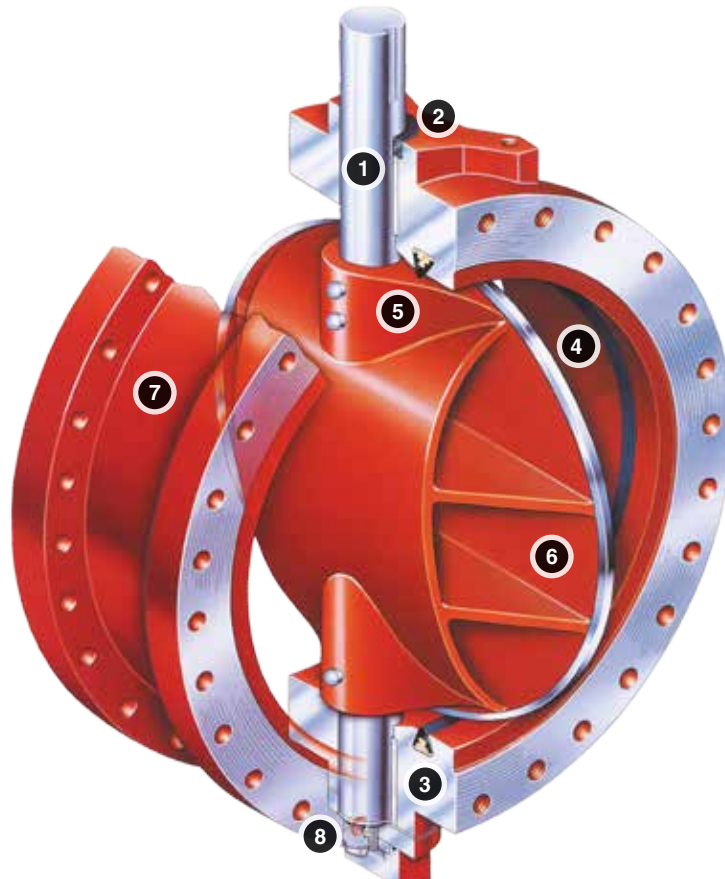

1 Corrosion-Resistant Shaft

Constructed of ASTM A-564 Type 630 H-1150 stainless steel. Two-piece, stub-type shafts are sized per AWWA Standard C504.

2 Chevron V-Type Packing

Self-adjusting packing in top trunnion of valve body where shaft protrudes.

3 Self-Lubricating Bearings

Sleeve-type bearings are used in both trunnions of the valve body. Teflon lined with special non-metallic backing. Provide electrical insulation between disc and shaft to prevent galvanic corrosion. Low coefficient of friction reduces operating torque requirements.

4 Elastomeric Seat

Specially compounded Buna N seat seals a full 360° against a stainless steel spherical disc edge. Unique grooved-seat design, coupled with the wide spherically shaped seating edge of the disc, allows greater disc closure tolerance (up to 1° off center in closed position without leakage). Seat is mechanically retained in body without metal hardware by a cast epoxy compound that ensures the seat conforms to the precise radius of the disc with uniform contact pressure. It is fully field adjustable and replaceable.

5 Strong Shaft Connections

Discs and shafts are connected by tapered stainless steel pins designed to transmit required torques and withstand stresses imposed under severe operating conditions.

6 Flow-Through Disc

Provides less pressure drop in full-open position than conventional disc shapes (on 24" size the arch side of the disc is closed and the flat side is open, forming a slightly concave surface**). Disc structure has no internal cores that can shift during casting, no hollow chambers that can collect water, freeze and fracture the disc. Disc edge has stainless steel spherically shaped seating surface. Ductile iron ASTM A-536 (65-45-12) used for Lineaseal III®, Lineaseal XP II®, Lineaseal XP™, and Lineaseal 350™ valves.

7 Heavy-Duty Body

Rugged cast iron ASTM-126 Class B construction for Lineaseal III valves, or ductile iron ASTM A-536 (65-45-12) for Lineaseal XP II, Lineaseal XP, and Lineaseal 350 valves. End connections include choice of flanges fully faced and drilled per ANSI B16.1 Class 125 or Class 250, or integrally cast mechanical joint ends. For Lineaseal III valves, slip-on ends (for ductile iron and PVC C900 pipe) are also available.

8 Preset Thrust Bearing Assembly

Two-way bearing is preset at factory. On valves 30" and larger, assembly consists of stainless steel stud fastened to the bottom of the valve shaft. Stud extends beyond the bottom cover. Thrust collar is threaded to the collar and pinned. On 24" size, thrust collar is pinned to shaft and adjustment provided by bronze spacers. Thrust collar cavity is packed with grease and fully gasketed to prevent leakage.

* Contact your Mueller sales representative for valve sizes larger than 48".
E-LOK seat design also applies to 6"-20" Lineaseal XP valves and all sizes of Lineaseal 350 valves.

** Also 6"-20" Lineaseal XP valves.

Buried Service Actuators

Built extra strong and water tight for years of trouble-free service.

1 Housing

Provides structural support plus protection for internal operating mechanism. Mounts to valve trunnion with four bolts. Gasket between housing and cover prevents infiltration of dirt and moisture.

2 Screw Rod

Precision machined, high strength steel. Transmits input torque to drive mechanism.

3 Stop Limiting Collars

Built-in, threaded into position, and pinned. Meets or exceeds AWWA C504 Standard for input torque requirements to eliminate the possibility of damage to actuator housing, mechanism, or disc-shaft assembly.

4 Lever

Rugged casting built to transmit torques from slider nut to valve shaft. On link-lever design, takes up higher portion of nut movement at the “closing” end of the screw.

5 Key

Actuator is keyed to valve shaft for positive connection.

6 Slide Nut

Precision machined to mate precisely with screw rod and lever. Capable of withstanding 450 ft. lb. input torque against stop collar.

7 Dual Link Construction

One link above the screw (shown) and one below (hidden), adds strength and prevents misalignment and jamming of the slider nut.

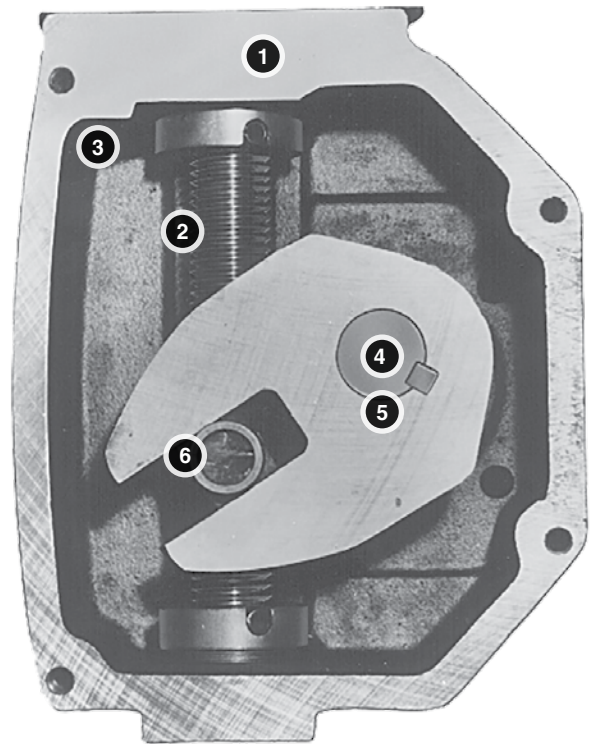

Slotted-lever actuator

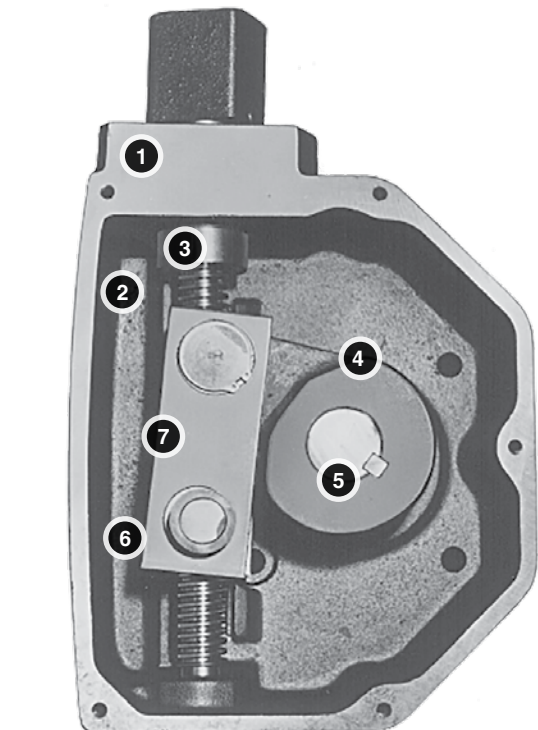

Link-lever actuator

Slotted-Lever Actuator
MTD-2S

Link-Lever Actuator
MTD-3S
MTD-4S
MTD-5
MTD-5S
MTD-6S

Ground Level Position Indicator

Diviner® Ground Level Position Indicator

A useful accessory that identifies valve position at a glance, direction, and number of turns to open or close completely. This durable indicator is designed for simple operation, strength and reliability. All working parts are constructed of non-metallic material that is virtually indestructible in this kind of service. Weatherproof, the internal gearing is protected from the elements with a clear, tough plastic cover.

The Diviner position indicator is shipped for field assembly complete with cast iron adapter (1) and cap screws, guide bushings (2), position indicator (3), flexible washer (4), and a two-inch square AWWA nut (5) with set screw. The adapter fits a standard 5 1/4 inch valve box (6) or 5 inch cast iron soil pipe bell utilizing a cast valve box cover with skirt depth of 1" or less (7). Extension stems (8) are available in 5-foot and 10-foot lengths and can be ordered separately at extra cost.

The device is designed for use with valves requiring 250 turns or less.



Typical application
in 5" soilpipe

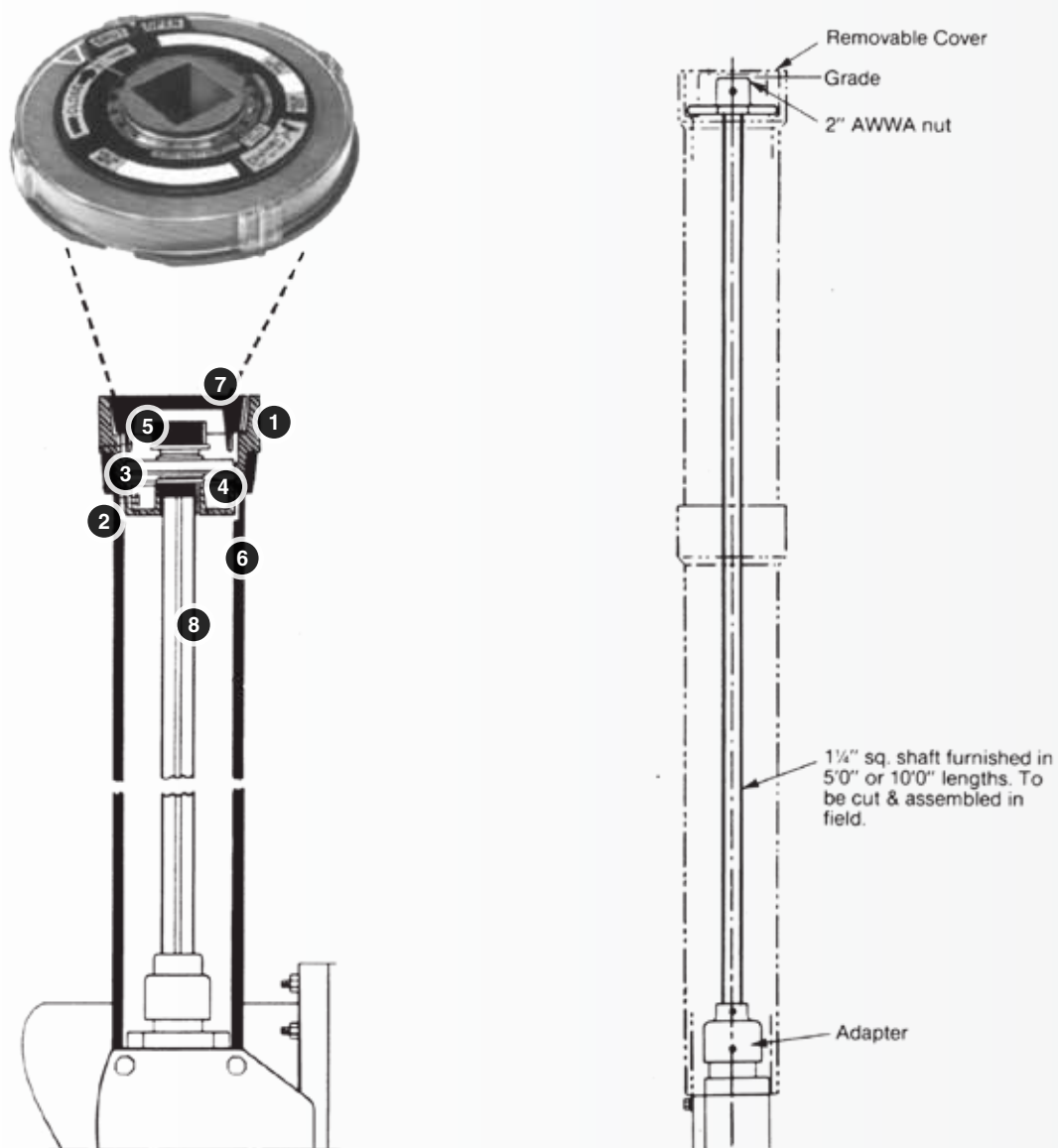



Our Products

Mueller Co. has built its reputation on producing innovative water distribution products of superior quality – a reputation that is literally “on the line” every day throughout the world. Mueller Co. products and those of its affiliates are used throughout the water system from the source to the consumer. We are committed to continuing research and development of new products and services to meet the growing needs of the water infrastructure industry. Mueller Co. is the largest and only full-line supplier of potable water distribution products in North America and its markets continue to expand globally.

Our People

The capacity to deliver the widest array of products and stand behind those products to ensure your satisfaction is our strength. The success of Mueller Co. is dependent upon the success of those who are involved, both inside and outside our company. Therefore, we feel our future is wholly dependent on long-term relationships with our employees, customers and suppliers. This is why we strive to be proactive and responsive to their needs, always looking for a “better way”. It’s an approach that has set us apart since 1857 and will assure our mutual achievement and prosperity in the future.

For more information about Mueller Co. or to view our full line of water products, please visit www.muellercompany.com or call Mueller Customer Service at 1.800.423.1323.

Follow Us:



Other Innovative Mueller Products

Mueller® Super Centurion® 350™ Hydrant

- 350 psig (2400 kPa/24 Barg) working pressure, 700 psig (4800 kPa/48 Barg) test pressure
- Sealed oil reservoir with automatic pressure lubrication
- Entire hydrant - epoxy coating inside and out inhibits corrosion
- Convenient, reversible main valve doubles service life
- Efficient hydraulic design provides maximum flow
- Certified to ANSI/NSF 61, ANSI/NSF 372
- 10-year limited warranty



Mueller Co. LLC
633 Chestnut St., Suite 1200
Chattanooga, TN 37450
www.muellercompany.com
moreinfo@muellercompany.com

Toll Free: 1.800.423.1323
Canada: 1.705.719.9965
International: 1.423.490.9555

Copyright © 2017 Mueller Co., LLC. All Rights Reserved.

The trademarks, logos and service marks displayed in this document herein are the property of Mueller Co., LLC, its affiliates or other third parties. Products above marked with a section symbol (§) are subject to patents or patent applications. For details, visit www.mwppat.com. These products are intended for use in potable water applications. Please contact your Mueller Sales or Customer Service Representative concerning any other application(s).

Form 11907 - Rev 1/17