

MUELLER®

Mega-Cut™ Drilling Machine

⚠ WARNING:

1. Read and follow instructions carefully. Proper training and periodic review regarding the use of this equipment is essential to prevent possible serious injury and/or property damage. The instructions contained herein were developed for using this equipment on fittings of Mueller manufacturer only, and may not be applicable for any other use.
2. DO NOT exceed the pressure ratings of any components or equipment. Exceeding the rated pressure may result in serious injury and/or property damage.
3. Safety goggles and other appropriate protective gear should be used. Failure to do so could result in serious injury.
4. Pressure test, check for and repair leaks in all fittings and components each time one is installed or any joint or connection is broken. Failure to find and repair a leak from any source in the fittings, by-pass lines or equipment could result in an explosion and subsequent serious injury and/or property damage.
5. Mueller® Drilling Machines and Equipment have been carefully designed and engineered to work together as a unit. The use of equipment manufactured by someone other than Mueller Co. may cause excessive wear or a malfunction of the Mueller machines.

TABLE OF CONTENTS PAGE

General Information	2
Installation / Operating Instructions	3
Parts	4

Mueller Co.

Reliable Connections™

Customer Service Center

Decatur, Illinois

1.800.423.1323 • 1.800.798.3131

www.muellercompany.com • www.muellergas.com

moreinfo@muellercompany.com

All warranties, expressed or implied, for Mueller Drilling Machines are rendered null and void if the machines are used with shell cutters or equipment manufactured by someone other than Mueller Co.

MUELLER® Mega-Cut™ Drilling Machine

General Information

Capacity and Use

The Mueller® Mega-Cut™ Drilling Machine is used to install up to 2" corporation valves using a service saddle on PVC plastic, cast or ductile iron, or steel water main. The maximum hole size is 1⁷/₈". The machine operates easily by hand, and allows independent control of tool rotation (cutting action) and boring bar feed (tool advancement). It includes a feature that allows the boring bar to be disconnected from the feed sleeve and repositioned quickly.

⚠ CAUTION: Use of serrated jaw wrenches or pipe wrenches on any machine parts or accessories may result in deformation or other damage which would render the machine or an accessory unusable. Use only smooth jawed wrenches with this equipment.

Working Pressure and Temperature Rating

200 psi Maximum Working Pressure
150° F Maximum Temp. Rating

The working pressure or temperature rating is reduced accordingly if any attachment, valve, or fitting subjected to pressure or temperature during the drilling operation has a maximum working pressure or temperature rating less than that specified above.

Length of Travel – 12¹/₈" (308 mm)

Mega-Cut™ Drilling Machine Guide

Machine	Drill or Cutter Capacity	Maximum Pressure	Operation	Type of Pipe	Recommended Use
Mega-Cut Drilling Machine	7 ¹ / ₁₆ " – 1 ⁷ / ₈ "	200 psig (1379 kPa/ 13.80 bar)	Hand Only	All Types*	Pressurized or Dry Mains

*Use on cast iron O.D. PVC pipe, as well as cast iron or ductile iron pipe, cement lined cast iron or ductile iron pipe, A-C pipe, steel pipe, or concrete pipe.

Other Equipment Required

The following items are not supplied with the machine and are purchased separately, according to the application — see the current Mueller Water Distribution Products Catalog.

- **Machine Adapter**
Machine Adapter Gasket (Supplied with Adapter)
- **Shell Cutter or Drill**
- **Wrench/Socket***
To drive Boring Bar
- **Cutting Grease**

Also Needed: Smooth-jawed wrench to tighten Machine Adapter and Shell Cutter to Mega-Cut™ Drilling Machine and adapter to corporation valve outlet. Also, when working on PVC plastic pipe a Drift Pin (Part Number 63264) or Coupon Removal tool (Part Number 681242) are needed to remove coupon from Shell Cutter.

*Machine Drive Nut will accommodate 7¹/₈" socket.

Shipping Specifications

DESCRIPTION	Mega-Cut™
Total Shipping Weight	29 lbs (13 kg)
Machine ONLY Weight	19 lbs (9 kg)
Shipping Length	21 ¹ / ₂ "
Extended Length	32"



Installation of Corporation Valve with Service Clamp on Water Main

Machine Set Up

1. Attach service saddle and corporation valve at the appropriate angle to the water main using accepted installation procedures, and tighten all components to specified torque requirements. Make sure corporation valve is in fully open position.
2. Attach proper Machine Adapter and Gasket to Machine Body wrench tight using a smooth-jawed wrench. Selection of Adapter depends upon the type and size of outlet connection on the corporation valve.
3. Attach proper Shell Cutter or Drill to Boring Bar. Use wrench flats on tool and Machine Body to tighten securely — DO NOT use any tool in the slots of the Shell Cutter.
4. Lightly lubricate outside of Shell Cutter or Drill using Mueller® Cutting Grease.
5. Disengage Feed Sleeve Connector from Feed Sleeve and pull Boring Bar to the rearmost position and hold in this position during the next step.
6. Check to be sure corporation valve is open. Attach Machine assembly (with Cutter, Adapter, and Gasket) to corporation valve outlet and tighten wrench tight.
7. Push Boring Bar forward until Feed Sleeve Connector can be engaged in slot at top of Feed Sleeve (turn the Sleeve **counter-clockwise** if necessary).
8. Turn Connector **clockwise** in slot, then advance Feed Sleeve by turning **clockwise** until Cutter contacts main.
9. Cut hole by turning Boring Bar **clockwise**, while turning Feed Sleeve **clockwise** a little at a time. DO NOT force Cutter into the main. Use a light even feed at the start, then a somewhat heavier feed and finish with a light even feed.
Completion of hole through the main will be accompanied by an obvious reduction in resistance felt while turning Boring Bar and Feed Sleeve.
IMPORTANT: Continue turning Boring Bar and Feed Sleeve a few additional revolutions to make sure the coupon is completely removed from the wall of the main.
⚠ CAUTION: To avoid possible injury, keep head and body away from the end of Boring Bar at all times. Once hole has been cut through the wall of the main, the Boring Bar will be under full line pressure, resulting in a piston action that will tend to force the Boring Bar to the rearmost position. Control or restrain rearward movement of Boring Bar at all times by keeping the Feed Sleeve Connector engaged with the Feed Sleeve, and by turning the Feed Sleeve in a counter-clockwise direction to back the Cutter out of the main and clear of the corporation valve.
10. Using both hands, turn Feed Sleeve in **counter-clockwise** direction to move Boring Bar to the rearmost position and retract Cutter from main. For larger holes or thicker pipe, a smooth-jawed wrench may be used on Feed Sleeve flats to facilitate turning Feed Sleeve.
11. Make sure Cutter is clear of corporation valve, then close valve and remove Machine and Adapter as a unit.
12. Remove plastic coupon using one of the following methods:
 - a) Use Drift Pin (Part Number 63264) to pry between the coupon and the top (or root) of the cutter slot and push the coupon from the cutter. If plastic fills the entire slot area, engage the plastic in the slot with the tip of the Drift Pin to drive the coupon from the cutter.
⚠ CAUTION: Prying against the sides of the cutter slot or using a prying tool that is wider than the slot can damage the cutter and make it unusable.
 - b) With the cutter removed from the machine, use a Coupon Removal Tool (Part Number 681242) inserted through the tapped hole in the cutter shank to drive the coupon out of the cutter.
13. Clean and relubricate cutting tool before using it to make another cut, or before storing tool for future use.

MUELLER® Mega-Cut™ Drilling Machine

Parts

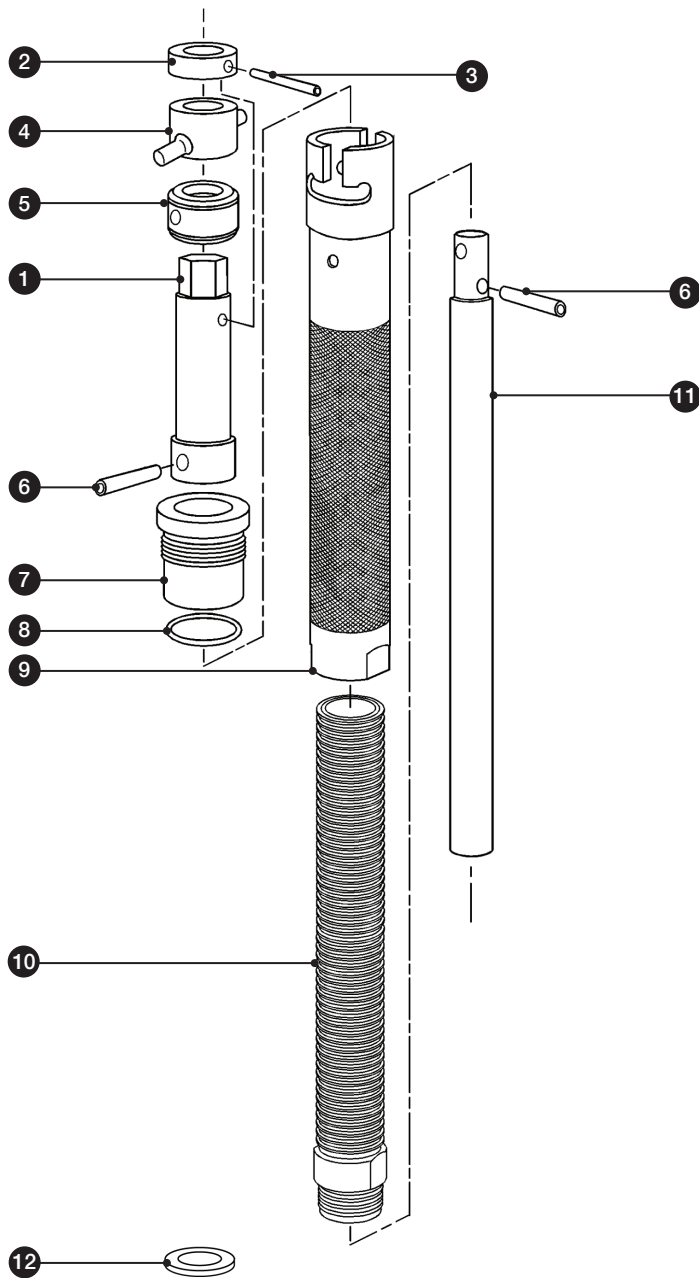

Parts List

ID	PART NAME	PART No.
-	Machine Complete	039432
1	Handle Extension	528094
2	Retaining Collar	52809
3	Pin	48130
4	Connector Assembly	682091
5	Bearing Assembly	580610
6	Pin	503158
7	Packing Gland	51432
8	O-Ring	46726
9	Feed Sleeve	528095
10	Body	503159
11	Boring Bar Tool End	503161
12	Body Gasket	47756

TO ORDER: Specify Quantity, Part Number and Part Name (include catalog number and model number of machine).

NOTE: These illustrations are for parts identification only. DO NOT use these illustrations for assembly or disassembly of machine. Mueller Co. offers a machine repair service. Contact Mueller Customer Service Center for details.



Reliable Connections®

Gas (North America)
1.800.798.3131
www.muellergas.com
moreinfo@muellercompany.com

Water (North America)
1.800.423.1323
www.muellercompany.com
moreinfo@muellercompany.com

International
1.423.490.9555
www.mueller-international.com
international@muellercompany.com