

# MUELLER

## SA-SERIES CHECK VALVE

### Easily Protect Against Accidental Contamination of the Water Supply

The Mueller® SA-Series check valve has male mechanical joint ends that attach directly to any standard 6" MJ connection without additional lengths of pipe. Its large 100% unobstructed flow path makes it specially suited for installation on fire hydrants and in wastewater applications.

The SA-Series valve makes it easy to protect against accidental or deliberate contamination of the water supply by way of fire hydrants. It attaches easily to the MJ shoe of any brand hydrant, where it provides round-the-clock protection without affecting normal hydrant operation and maintenance.

One moving part - an EPDM-encapsulated steel disc reinforced with nylon fabric - and a strong ductile iron body make this valve dependable and maintenance free. Other features include:

- Inherent non-slam, quiet operation
- Bubble-tight shut off, without backflow
- Swivel MJ gland on one end aids pipe or valve alignment
- Liquid thermosetting epoxy-coated interior
- Universal primer enamel on exterior
- Stainless steel bolts
- Domed bonnet for easy inspection of flexible disc and seat

The body seat is at a 45 degree angle to reduce the travel of the disc to the full open position, and significantly reduce the potential for water hammer when closing. The flow area is equal to or greater than the equivalent pipe size throughout for low head loss. The valve is suitable for horizontal or vertical (upward flow) mounting and is rated at 250 psig (1725 kPa/17 barg).



SA-SERIES CHECK VALVE WITH INTEGRAL MJ ENDS

## MATERIALS OF CONSTRUCTION

ITEM	DESCRIPTION	MATERIAL	ASTM DESIGNATION
1	Body	Ductile Iron	A-536 Grade 65-45-12
2	Washer	Stainless Steel	A276 Type 304
3	Cover Bolt	Stainless Steel	A276 Type 304
4	Cover	Ductile Iron	A-536 Grade 65-45-12
5	Disc	Ductile Iron & Rubber	A-536 Grade 65-45-12 & D2000
6	O-ring	Rubber (Buna-N)	D2000
7	Swivel Flange	Ductile Iron	A-536 Grade 65-45-12

## DIMENSION 'F' CLEARANCE REQUIRED TO REMOVE ACCESS COVER

VALVE SIZE	A	B	C	D	E	F
6	17.63"	24.5"	6.9"	8.02"	6.81"	11.00"

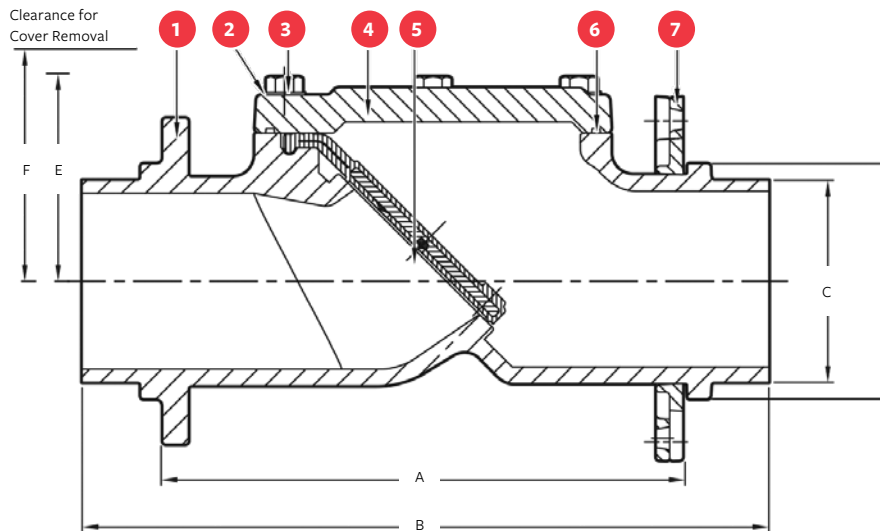

## SUGGESTED SPECIFICATION

Check valve shall be of the anchoring type (male mechanical joint on one end, male mechanical joint with swivel gland on other end) with no internal moving parts except the resilient disc. Valves shall be rated to 250 psig.

The valve body shall be constructed of ductile iron ASTM A-526 Grade 65-45-12 with flow area control to the nominal pipe inside diameter throughout the valve. Seat shall be constructed on a 45 degree angle to reduce disc travel. The seat and internal body shall be fully coated with a two part thermosetting epoxy suitable for use in both potable water and wastewater applications.

The domes bonnet shall be manufactured of ductile iron ASTM A-536 Grade 65-45-12. The bonnet-to-body seal shall be provided by a gasket to allow easy removal and replacement of the access bonnet. Bonnet bolting shall be 304 stainless steel.

The resilient disc shall feature a fully encapsulated steel pressure plate with integral molded O-ring on the face of the elastomer. Nylon reinforcements shall be provided in the flexible hinge area of the disc assembly.

**For more information about us or to view our full line of water products, please visit [www.muellerwp.com](http://www.muellerwp.com) or call Mueller customer service at:**

**UK: +44.1438.487410 Dubai: +971.4.214.6640 Singapore: +65.6816.3088 USA: 800.423.1323**

Mueller refers to one or more of Mueller Water Products, Inc. a Delaware corporation ("MWP"), and its subsidiaries. MWP and each of its subsidiaries are legally separate and independent entities when providing products and services. MWP does not provide products or services to third parties. MWP and each of its subsidiaries are liable only for their own acts and omissions and not those of each other. MWP brands include Mueller®, Echologics®, Hydro Gate®, Hydro-Guard®, Jones®, Krausz®, Mi.Net®, Milliken®, Pratt®, Pratt Industrial®, Singer®, and U.S. Pipe Valve & Hydrant. Please see [muellerwp.com/brands](http://muellerwp.com/brands) to learn more.

© 2020 Mueller Water Products, Inc. All Rights Reserved. The trademarks, logos and service marks displayed in this document are the property of Mueller Water Products, Inc., its affiliates or other third parties. Products above marked with a section symbol (§) are subject to patents or patent applications. For details visit [www.mwppat.com](http://www.mwppat.com).

F 12529 9/20

