

MUELLER®

2300 Series Resilient Wedge Gate Valve

TABLE OF CONTENTS	PAGE
Application/Maintenance/Installation	2
Installation/Operation	2-3
Repairs	4-5
Parts	6-8

⚠ WARNING:

1. Read and follow instructions carefully. Proper training and periodic review regarding the use of this equipment is essential to prevent possible serious injury and/or property damage. The instructions contained herein were developed for using this equipment on fittings manufactured by Mueller Co. only, and may not be applicable for any other use.
2. Do not exceed the pressure ratings of any components or equipment. Exceeding the rated pressure may result in serious injury and/or property damage.
3. Safety goggles and other appropriate protective gear should be used. Failure to do so could result in serious injury.

Mueller Co.

Reliable Connections®

Customer Service Center

Decatur, Illinois

800.423.1323

www.muellercompany.com

moreinfo@muellercompany.com

MUELLER® 2300 Series Resilient Wedge Gate Valve

Application/Maintenance/Installation

APPLICATION

Mueller® 2300 Series Resilient Wedge Gate Valves are intended for use in potable water distribution or fire protection systems. One or more of the following publications may be applicable to the installation or testing of the valve:

1. AWWA C-509 Thick Wall Resilient Seated Gate Valves 2” through 12” Nominal Pipe Size
2. AWWA C-515 Thin Wall Resilient Seated Gate Valves 3” through 54” Nominal Pipe Size
3. AWWA C-600 Installation of Ductile Iron Water Mains and Main Appurtenances
4. All installation, operation and maintenance instructions issued by the manufacturer of the pipe and the valves.
5. Valve user guide as published by MSS.
6. AWWA M-44 Distribution Valves: Selection, Installation, Field Testing and Maintenance.
7. NFPA-24 – Standard for the installation of Private Fire Service Mains and their appurtenances.

ROUTINE MAINTENANCE

Mueller® Resilient Wedge Valves include design features that ease operation, minimize wear on the working parts of the valve, and contribute to a long service life without routine maintenance – other than following the recommendations in AWWA

Publication M-44, Distribution Valves: Selection, Installation, Field Testing and Maintenance for valves in water works applications. As recommended by that publication, every valve should be operated through a full close and open cycle on a regular schedule to clear the

operating stem and wedge guides of naturally occurring encrustation or other debris.

For valves in fire protection applications, guidelines from the National Fire Protection Association (NFPA) should be followed.

INSTALLATION

Adhere to guidelines provided by AWWA M-44 or NFPA publications, depending upon the valve application, as they might be amended by the distribution or fire protection system owner.

properly. Also check opening direction against the order instruction.

4. Any problems should be reported immediately to Trucker and noted on bill of lading, and signed by the driver on customer’s copy.

Storage

1. Valves should be stored in a partially open position.
2. When possible, keep valves out of the weather.
3. In cold climates the inside of the valve must be kept drained of any water to prevent freezing.

4. When stored outside, valve stem should be in a vertical position, and whenever possible, valves should be covered with a water-proof covering.

5. Protect all parts of the valve at all times.

6. Protect rubber seat of resilient wedge valves from ozone and hydrocarbons (solvents, paints and oils, etc.).

Inspection On Delivery

1. Check for possible damage in shipment, conformance to specifications, opening direction, shortages, etc.
2. Carefully unload all valves - do not drop valve – do not lift valve using gearing, bypass or other appendage as a hook.
3. Valve should be opened and then closed to make sure it works

MUELLER® 2300 Series Resilient Wedge Gate Valve

Installation/Operation

INSTALLATION (cont.)

Inspection Before Installation

1. Check to see the valve end-joints are clean.
2. Check valve for damage.
3. Open and close valve - make sure it works properly.
4. Keep valve closed when placing in trench.
5. Inspect casting for damage.
6. Inspect epoxy coating and repair breaks using compatible coating material.

Installation

1. Flush the water line completely.
2. Handle valve carefully.
3. Prepare pipe ends in accordance with pipe manufacturers' instructions.

4. Install valve using appropriate instructions for the specified joint (flanged, mechanical joint, slip-on, etc.).
5. Water piping should be properly supported to avoid line stress on valve.
6. In buried applications, make sure that the valve box does not transmit traffic loads or other stress to the valve.
7. Do not use valves to force a pipeline into position.
8. Do not deflect any valve/pipe joint.
9. Protect exterior epoxy coating during backfill.

Testing

1. Do not backfill valves before hydrostatic system test. Leave the valves exposed while the pipeline is being pressurized. Check to see that all valve joints and pressure containing bolting, including bonnet bolts, are tight.
2. Valves can be shell tested (but not operated) at two times the rated pressure of the valve.
3. After testing, steps should be taken to relieve any trapped pressure in body of valves.

OPERATION

The operation of a resilient wedge valve will "feel" different to the valve operator compared to an older style double-disc gate valve. In normal

circumstances, less operating torque is required as the resilient wedge valve just closes, or on opening. Valve operators should be instructed

to adhere to the 'number of turns to open' for the size of valve in question rather than rely only upon the feel of the valve.

Number of Turns & Max. Torque in ft.-lbs. to Close Mueller Resilient Wedge Gate Valves*

Valve Size	2"	2½"	3"	4"	6"	8"	10"	12"	14"	16"	18"	20"	24"	30"	36"	42"	48"	54"
	8 20	11 28	11 52	14 75	21 110	27 150	33 185	39 225	44 225	49 275	57 275	63 300	75 325	93 450	111 550	131 700	149 800	149 1000
Spur Gearing	-- --	-- --	-- --	28 41	41 60	53 82	66 101	77 123	178 61	201 75	234 75	258 81	308 88	381 122	455 149	524 199	596 227	596 284
Bevel Gearing	-- --	-- --	22 31	28 44	41 65	53 88	66 109	77 132	174 66	196 81	228 81	252 88	300 96	372 132	444 162	524 206	596 235	596 294

*Always refer to the current catalog for accurate "turns to close" information – all numbers in chart are for valves without actuators. All valves 30" and larger require the use of actuators. Torque values are for dry (no flow) conditions per accepted industry practice – and refer to torque required to affect a seal. Torque under flow conditions are typically less than the values shown.

MUELLER® 2300 Series Resilient Wedge Gate Valve

Repairs

REPAIRS

Mueller valves are designed to operate without requiring rebuild or repair through their normal service life, therefore Mueller Co. does not recommend stocking valve parts. However, it is possible to replace Bonnet O-rings, Dirt Seal (4"-12" valves), the Stem or Wedge (or packing on OS&Y valves), although it is very unlikely such repairs will ever be needed. Refer to the Mueller Water Distribution Products Catalog for parts listings and provide the following information if parts are ordered:

1. Type of valve (NRS, OS&Y) and model number on Bonnet
2. Year date (cast in valve body)
3. Valve size (cast in valve body)

NRS Stem O-rings and Dirt Seal

There is a Dirt Seal (4"-12" valves) and two O-rings above the thrust collar that can be replaced with the valve in service (a third O-ring below the Thrust Collar can only be replaced if the main is shut down and drained).

1. Turn the Stem in the opening direction until the valve is fully opened and tighten firmly.
2. Remove the Operating Nut, and the bolts holding the Stuffing Box.
3. Clean the exposed Stem to remove all debris and grit.
4. Carefully pry the Stuffing Box loose, avoiding damaging the valve's exterior coating – slide the Stuffing Box off the Stem. (At this point, avoid getting dirt into the thrust collar area – cover the exposed thrust collar area with sheet plastic or a clean rag to exclude contamination.)
5. Remove the Dirt Seal from the Stuffing Box, the two O-rings from the exposed stem, and the Stuffing Box Seal inside the top of the valve Bonnet.

6. Wipe the Stem and inside bore of the Stuffing Box, then liberally lubricate these areas, especially the flat surface on the bottom of the Stuffing Box that will contact the Thrust Collar.
7. Lubricate the new Dirt Seal in the Stuffing Box and/or O-rings and install them on the Stem.
8. Lubricate and install a new Stuffing Box seal O-ring in the top of the Bonnet.
9. Reinstall the Stuffing Box and its bolts, and uniformly tighten the bolts to the torque shown below, so the gap between the Stuffing Box and Bonnet is even all around. Check the Stem for binding.
10. Replace the Operating Nut.

Valve Size	Stuffing Box Bolt Size	Torque (ft-lbs)	
		Carbon (Grade 2)	Stainless
2"	1/2"	45	45
2 1/2"	1/2"	45	45
3"	1/2"	45	45
4"	5/8"	90	90
6"	5/8"	90	90
8"	5/8"	90	90
10"	5/8"	90	90
12"	5/8"	90	90
14"	3/4"	150	125
16"	3/4"	150	125
18"	3/4"	150	125
20"	3/4"	150	125
24"	3/4"	150	125
30"	7/8"	200	200
36"	7/8"	200	200
42"	1"	300	260
48"	1"	300	260
54"	1"	300	260

OS&Y Packing

Try adjusting the Packing Gland before resorting to replacing the Packing by tightening both Gland Bolts equal amounts.

1. Turn the Stem in the opening direction until the valve is fully opened and tighten firmly.
2. Remove the nuts from both Gland Bolts.
3. Lift the Packing Gland up the valve Stem and secure it out of the way using string or wire.
4. Remove and replace the Packing.
5. Lower the Gland against the new packing, reinstall the Gland Bolts and tighten securely.

If necessary to compact the new packing sufficiently to install the Gland Bolts, temporarily install longer bolts or short lengths of threaded rod and tighten them, then reinstall the standard Gland Bolts.

MUELLER® 2300 Series Resilient Wedge Gate Valve

Repairs

Stem or Wedge Replacement

It will be necessary to shut down and drain the main, but the valve can remain in the line. Because it is so unusual to have to replace a Stem or Wedge, first reconfirm that the valve is properly and tightly closed. Open and close the valve repeatedly to attempt to flush away debris from the seating area that might hinder the valve from closing fully.

1. Shut down and drain the main in the area of the valve.
2. Operate the stem in the opening direction several turns.
3. Remove the Bonnet Bolts and lift the Bonnet-Stem-Wedge assembly from the valve Body.
4. Replace the Stem and/or Wedge. (If necessary, transfer or install new Guide Cap Bearings on each side of the new Wedge.)
5. Wipe debris from the top flange of the valve Body and replace the

Bonnet O-ring (or flat Gasket if used) if necessary.

6. Replace the Bonnet-Stem-Wedge assembly, taking care to align the Wedge Guides into their slots on each side of the Body cavity.
7. Install the Bonnet Bolts and Nuts, and tight each finger tight until the Bonnet casting is evenly seated on top of the valve body all around.
8. Snug two Bonnet Bolts on diagonally opposite sides of the valve. Then tighten two other diagonally opposite bolts more tightly than the first two. Finally tighten all bolts, working diagonally side to side and all around until all bolts are tightened to the torque shown on right.
9. Operate the valve fully open to fully closed counting the number of turns and compare the number to the chart value elsewhere in this manual to verify correct operation.

Valve Size	Bonnet Bolt Size	Torque (ft-lbs)	
		Carbon (Grade 2)	Stainless
2"	1/2"	45	45
2 1/2"	1/2"	45	45
3"	1/2"	45	45
4"	1/2"	45	45
6"	1/2"	45	45
6**	5/8"	90	90
8"	5/8"	90	90
8**	3/4"	150	125
10"	3/4"	150	125
12"	3/4"	150	125
14"	3/4"	150	125
16"	3/4"	150	125
18"	7/8"	200	200
20"	7/8"	200	200
24"	7/8"	200	200
30"	1"	300	260
36"	1"	300	260
42"	1 1/4"	660	480
48"	1 1/4"	660	480
54"	1 1/4"	660	480

*2365 series valve only

ANSI B16.1 Class 125 Flange Dimensions – inches

Nominal Pipe Size	Diameter of Flange	Diameter of Bolt Circle	Number of Bolts	Diameter of Bolts	Diameter of Bolt Holes	Length of Bolts
2"	6	4 ^{3/4}	4	5/8	3/4	2 1/4
2 1/2"	7	5 1/2	4	5/8	3/4	2 1/2
3"	7 1/2	6	4	5/8	3/4	2 1/2
4"	9	7 1/2	8	5/8	3/4	3
6"	11	9 1/2	8	3/4	7/8	3 1/4
8"	13 1/2	11 3/4	8	3/4	7/8	3 1/2
10"	16	14 1/4	12	7/8	1	3 1/2
12"	19	17	12	7/8	1	3 3/4
14"	21	18 3/4	12	1	1 1/8	4 1/4
16"	23 1/2	21 1/4	16	1	1 1/8	4 1/2
18"	25	22 3/4	16	1 1/8	1 1/4	4 3/4
20"	27 1/2	25	20	1 1/8	1 1/4	5
24"	32	29 1/2	20	1 1/4	1 3/8	5 1/2
30"	38 3/4	36	28	1 1/4	1 3/8	6 1/4
36"	46	42 3/4	32	1 5/8	1 5/8	7
42"	53	49 1/2	36	1 5/8	1 5/8	7 1/2
48"	59 1/2	56	44	1 5/8	1 5/8	7 3/4
54"	66 1/4	62 3/4	44	1 3/4	2	8 1/2

MUELLER® 2300 Series Resilient Wedge Gate Valve

RW Gate Valve A-2361 (350psi) Parts

PARTS LIST

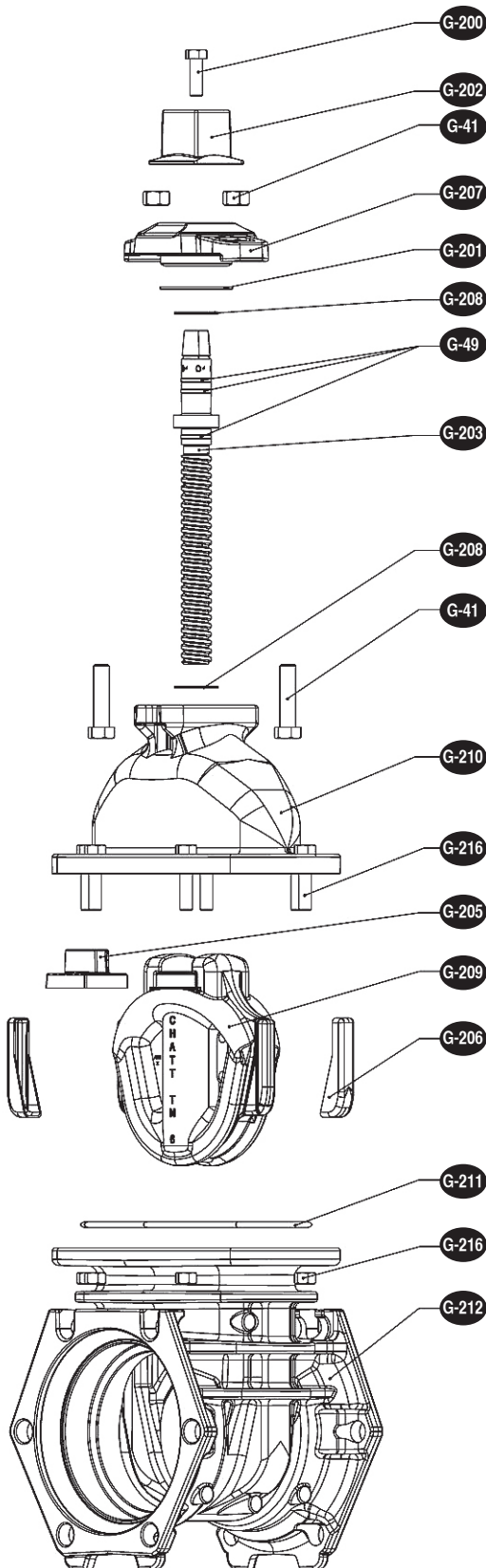

ID	DESCRIPTION	MATERIAL
G-41	Stuffing Box Bolts & Nuts	316 Stainless Steel
G-49	Stem O-Rings (3)	Nitrile
G-200	Wrench Nut Cap Screw	316 Stainless Steel
G-201	Stuffing Box Seal	Nitrile
G-202	Wrench Nut	Ductile Iron ASTM A536
G-203	Stem	Bronze ASTM B138
G-204	Hand Wheel (not shown)	Cast Iron ASTM A126 CL.B
G-205	Stem Nut	Bronze ASTM B584
G-206	Guide Cap Bearings	Acetal
G-207	Stuffing Box w/dirt seal	Ductile Iron ASTM A536
G-208	Anti-friction Washer (2)	Acetal
G-209	Wedge	Ductile Iron ASTM A536 Rubber Encapsulation, SBR
G-210	Bonnet	Ductile Iron ASTM A536
G-211	Bonnet O-Ring	Nitrile
G-212	Body	Ductile Iron ASTM A536
G-216	Bonnet Bolts & Nuts	316 Stainless Steel

MUELLER® 2300 Series Resilient Wedge Gate Valve

OS&Y RW Gate Valve R-2361 Parts

PARTS LIST

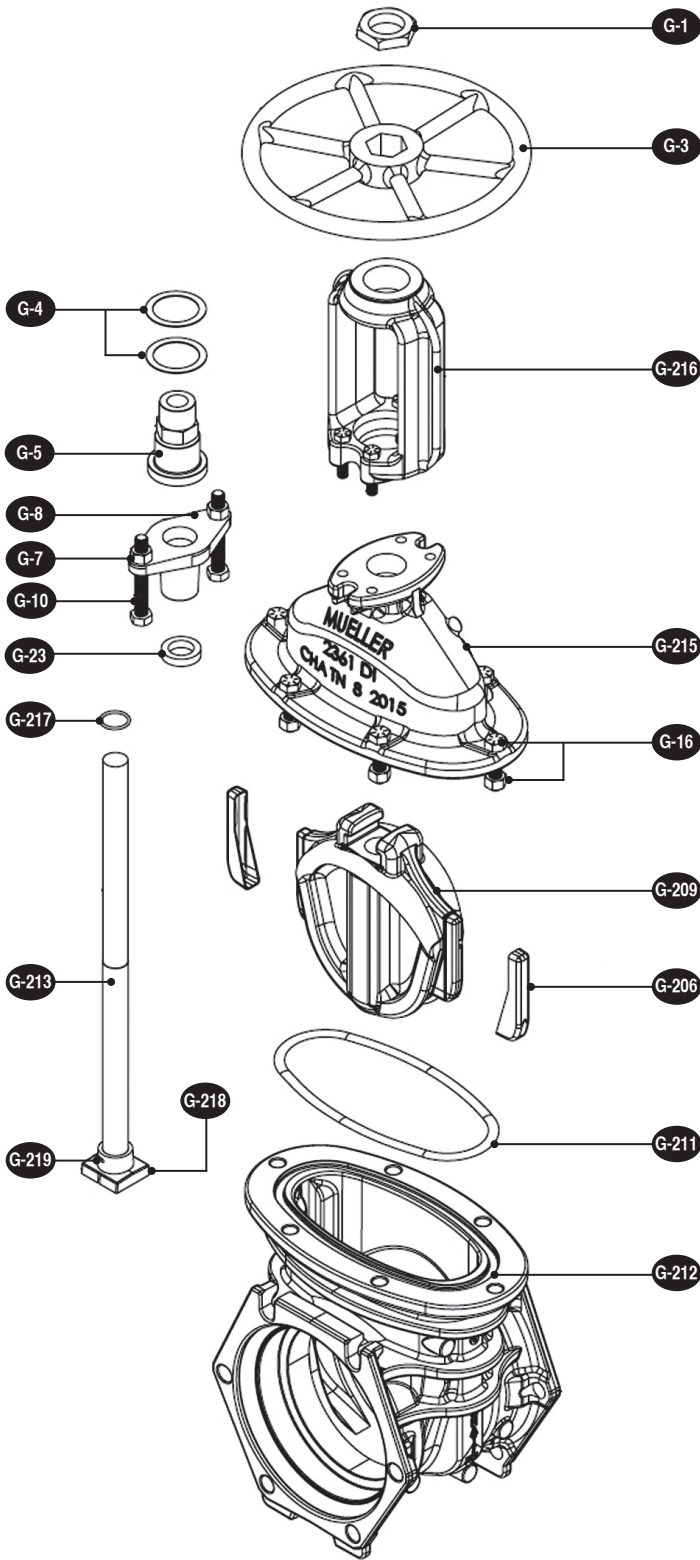

ID	DESCRIPTION	MATERIAL
G-1	Cap Nut	Bronze ASTM B62
G-3	Hand Wheel	Ductile Iron ASTM A536
G-4	Washer	Brass
G-5	Bush Nut	Bronze ASTM B62
G-7	Gland Nut	Bronze ASTM B21 Alloy 464
G-8	Packing Gland	Ductile Iron ASTM A536
G-10	Gland Bolt	316 Stainless Steel
G-16	Bonnet Bolts & Nuts	316 Stainless Steel
G-23	Stem Packing	Lubricated Flax
G-206	Guide Cap Bearings	Acetal
G-209	Wedge	Rubber Encapsulated – SBR Ductile Iron* ASTM A536
G-211	Bonnet O-Ring	Nitrile ASTM D2000
G-212	Body	Ductile Iron ASTM A536
G-213	Stem	Manganese Bronze ASTM B138
G-215	Bonnet	Ductile Iron ASTM A536
G-216	Yoke	Ductile Iron ASTM A536
G-217	O-Ring	Nitrile ASTM D2000
G-218	Disc Nut	Bronze ASTM B584
G-219	Stem Nut Pin	316 Stainless Steel

*Fully encapsulated in molded rubber with no iron exposed

MUELLER® 2300 Series Resilient Wedge Gate Valve

RW Gate Valve P-2361 (350psi) Parts

PARTS LIST

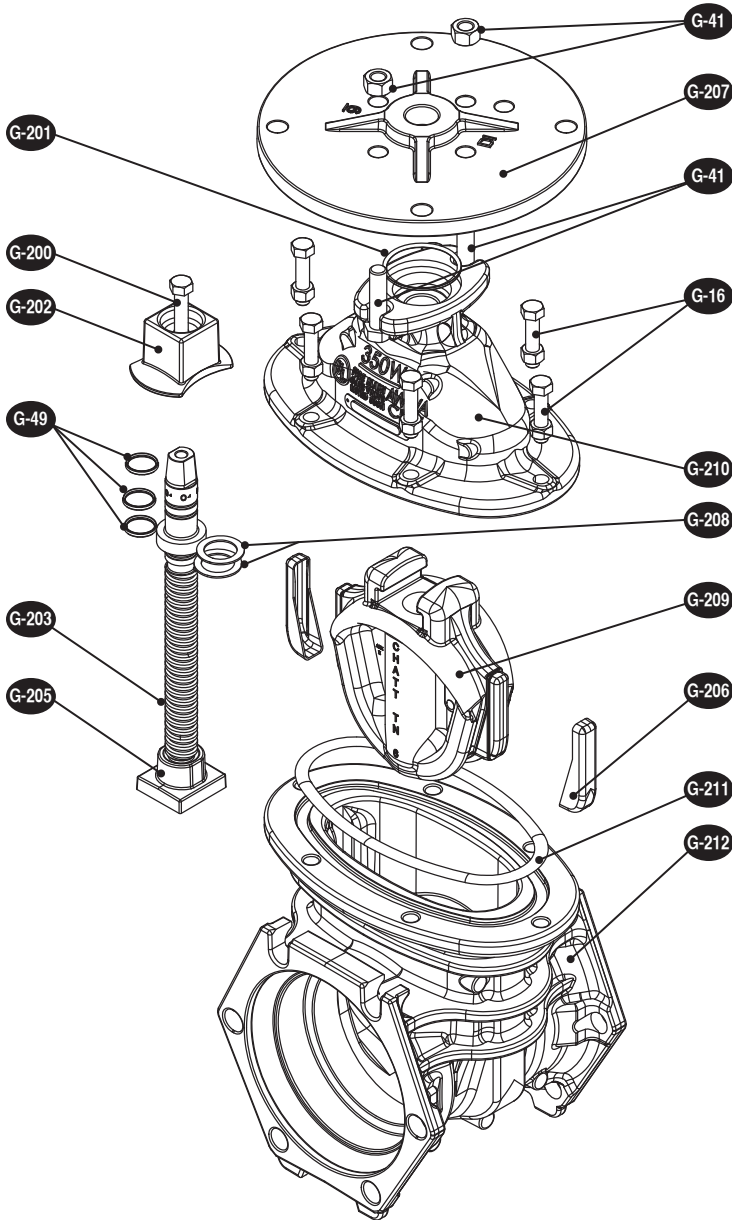

ID	DESCRIPTION	MATERIAL
G-16	Bonnet Bolts & Nuts	316 Stainless Steel
G-41	Stuffing Box Bolts & Nuts	316 Stainless Steel
G-49	Stem O-Rings (3)	Nitrile
G-200	Wrench Nut Cap Screw	316 Stainless Steel
G-201	Stuffing Box Seal	Nitrile
G-202	Wrench Nut	Ductile Iron ASTM A536
G-203	Stem	Bronze ASTM B138
G-205	Stem Nut	Bronze ASTM B584
G-206	Guide Cap Bearings	Acetal
G-207	Stuffing Box w/dirt seal	Ductile Iron ASTM A536
G-208	Anti-friction Washer (2)	Acetal
G-209	Wedge	Ductile Iron ASTM A536 Rubber Encapsulation, SBR
G-210	Bonnet	Ductile Iron ASTM A536
G-211	Bonnet O-Ring	Nitrile
G-212	Body	Ductile Iron ASTM A536



Reliable Connections

Water (U.S.)
1.800.423.1323
www.muellercompany.com
moreinfo@muellercompany.com

Water (Canada)
1.705.719.9965
www.muellercanada.com
more-info@muellercanada.com

International
1.423.490.9555
www.mueller-international.com
international@muellercompany.com