



**VALVE &
HYDRANT**

R-USP1 RESILIENT WEDGE GATE VALVE

OS&Y: 14" – 24"/DN350 – DN600

PRODUCT FEATURES

- Outside Screw & Yoke (OS&Y).
- 14" – 24"/DN350 – DN600*.
- Fusion Bonded Epoxy Coating inside and out covers all cast surfaces (10 mil/250 µm nominal); Meets requirements of AWWA/ANSI C550.
- Meets requirements of AWWA/ANSI C515 and is certified to ANSI/NSF 61 & 372.
- Ductile Iron wedge, symmetrical and fully encapsulated with molded rubber; no exposed iron.
- Polymer guide cap bearings on wedge guides resist wear and provide easy operation.
- Bi-directional flow.
- 10-year limited warranty.
- 14" & 16"/DN350 & DN400: UL 262 Listed/FM 1120/1130 Approved 250psig/17barg.
- 18" – 24"/DN450 – DN600: UL 262 Listed 175psig/12barg, FM Approved 250psig/17barg.
- AWWA C-515 14" – 24"/DN350 – DN600: 250psig/17barg.
- Flange End drilling meets: ANSI B16.1, Class 125 and ANSI B16.42, Class150 - Flat Face. 14" & 16"/DN350 & DN400 optional PN10, PN16 drilling.

*Resilient Wedge OS&Y Valves with similar performance and features, but different bonnet construction and bolting are available in 2" – 12"/DN50 – DN300 sizes, model R-USP1.

VALVE SIZE	WEIGHT - LBS (KG)
14"/DN350	775 (352)
16"/DN400	960 (435)
18"/DN450	1657 (752)
20"/DN500	2239 (1016)
24"/DN600	2899 (1315)

DIMENSIONS - INCHES (MM)

VALVE SIZE	A-CLOSED	AA-OPEN	B	C**
14"/DN350	49.13 (1248)	64.09 (1628)	15.06 (383)	24.92 (633)
16"/DN400	54.63 (1387)	71.19 (1808)	16.06 (408)	26.58 (675)
18"/DN450	67.82 (1723)	87.81 (2230)	17.00 (432)	30.50 (775)
20"/DN500	75.56 (1843)	94.35 (2396)	18.00 (457)	33.75 (857)
24"/DN600	82.42 (2093)	108.19 (2748)	20.00 (508)	39.50 (1003)

VALVE SIZE	ØD	ØE THRU Ø	ØF	G
14"/DN350	18.00 (457)	14.38 (365)	21.00 (533)	1.00 (25)
16"/DN400	18.00 (457)	16.00 (406)	23.50 (597)	1.00 (25)
18"/DN450	32.00 (813)	18.38 (467)	25.00 (635)	1.00 (25)
20"/DN500	32.00 (813)	20.38 (518)	27.50 (698)	1.13 (29)
24"/DN600	32.00 (813)	24.38 (619)	32.00 (813)	1.19 (30)

**C dimension is the overall width of the bonnet flange.

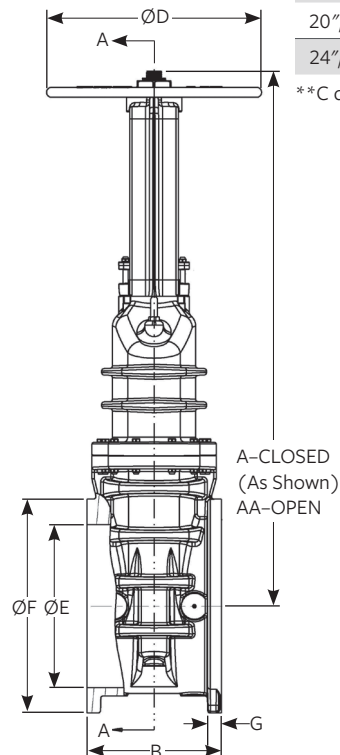

14" & 16"/DN350 & DN400 PARTS LIST

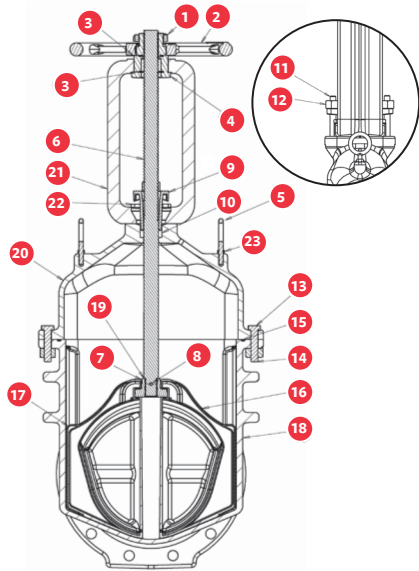

ID	PART NAME	MATERIAL
1	Cap Nut	Bronze ASTM B62
2	Handwheel	Cast Iron ASTM A126
3	Washer	Brass ASTM B36
4	Bush Nut	Bronze ASTM B584
5	Eyebolt	Forged Steel
6	Stem	Bronze ASTM B138 (C67600)
7	Disc Nut	Bronze ASTM B62
8	Pin	304 Stainless Steel
9	Gland Flange	Ductile Iron ASTM A536
10	Stem Packing	Lube Flax
11	Gland Bolt	316 Stainless Steel
12	Gland Nut	Silicon Bronze ASTM B98
13	Bonnet Bolt	316 Stainless Steel
14	Bonnet Nut	316 Stainless Steel
15	O-Ring	Nitrile ASTM D2000
16	Disc Rubber/Disc Casting	SBR ASTM D2000/Ductile Iron A536
17	Guide Cap	Acetal
18	Body	Ductile Iron ASTM A536
19	O-Ring	Nitrile ASTM D2000
20	Bonnet	Ductile Iron ASTM A536
21	Yoke	Cast Iron ASTM A126
22	Cap Screw	Carbon Steel ASTM A307
23	Hex Nut	Steel ASTM A563

18" & 24"/DN450 & DN600 PARTS LIST

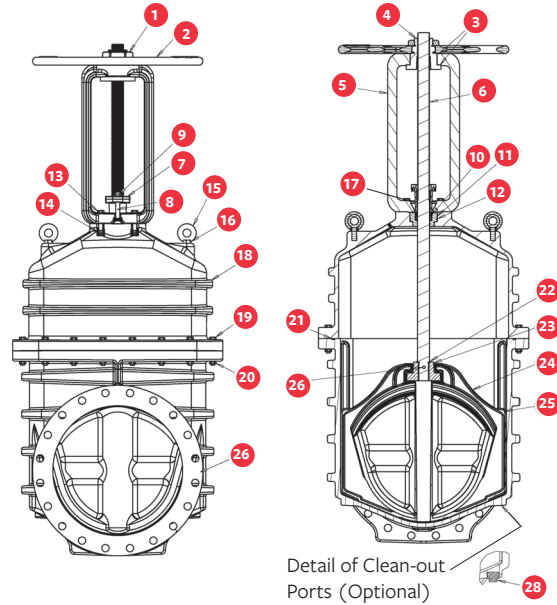

ID	PART NAME	MATERIAL
1	Cap Nut	Bronze ASTM B62
2	Handwheel	Ductile Iron ASTM A536
3	Thrust Washer	Brass ASTM B36
4	Bush Nut	Bronze ASTM B584
5	Yoke	Ductile Iron ASTM A536
6	Stem	Manganese Bronze ASTM B138 (C67600)
7	Gland Flange	Ductile Iron ASTM A536
8	Gland Bolt	316 Stainless Steel
9	Gland Nut	Silicon Bronze ASTM B98
10	Stem Packing	Lube Flax
11	Bonnet Bushing	Bronze ASTM B62
12	Bushing O-Ring	EPDM ASTM D2000
13	Yoke Bolt	316 Stainless Steel
14	Yoke Nut	316 Stainless Steel
15	Eyebolt	Steel
16	Eyebolt Nut	316 Stainless Steel
17	Cap Screw	Carbon Steel ASTM A307
18	Bonnet	Ductile Iron ASTM A536
19	Bonnet Bolt	316 Stainless Steel
20	Bonnet Nut	316 Stainless Steel
21	Bonnet O-Ring	EPDM ASTM D2000
22	Stem O-Ring	EPDM ASTM D2000
23	Disc Nut	Bronze ASTM B62
24	Disc	EPDM/Ductile Iron ASTM A563
25	Guide Cap	Acetal
26	Body	Ductile Iron ASTM A536
27	Pin	304 Stainless Steel
28	Pipe Plug	316 Stainless Steel

For more information about us, or to view our full line of products, please visit www.mueller-international.com or call International Customer Service at:

UK: +44.1438.487410 Dubai: +971.4.214.6640 Singapore: +65.6816.3088 USA: +1.800.423.1323 | International@muellerwp.com

Mueller refers to one or more of Mueller Water Products, Inc., a Delaware corporation ("MWP"), and its subsidiaries. MWP and each of its subsidiaries are legally separate and independent entities when providing products and services. MWP does not provide products or services to third parties. MWP and each of its subsidiaries are liable only for their own acts and omissions and not those of each other. MWP brands include Mueller®, Echologics®, Hydro Gate®, Hydro-Guard®, Jones®, Krausz®, MiNet®, Milliken®, Pratt®, Pratt Industrial®, Singer®, and U.S. Pipe Valve & Hydrant. Please see muellerwp.com/brands to learn more.

© 2020 Mueller Water Products, Inc. All Rights Reserved. The trademarks, logos and service marks displayed in this document are the property of Mueller Water Products, Inc., its affiliates or other third parties. Products above marked with a section symbol (§) are subject to patents or patent applications. For details visit www.muellerwp.com.

F 12904 3/20

MUELLER