

MUELLER

350 PSI RESILIENT WEDGE GATE VALVES

Meets AWWA, UL Listed/FM Approved; Certified to ANSI/NSF 61, ANSI/NSF 372





MUELLER® 350 PSI RESILIENT WEDGE A-2361 GATE VALVES

SIZES 3" - 12"

1 Triple O-rings and Dirt Seal

A dirt seal at the top keeps out debris. Two O-rings above the stem thrust collar bearing area isolate it from ground contaminants, and one below isolates it from the waterway. The two upper O-rings and the dirt seal can easily be replaced in the line while the valve is under pressure in the fully open position.

2 Forged Bronze Stem and Thrust Collar

This time-tested Mueller design has two thrust washers and has repeatedly proven its superior strength over cast stems.

3 O-ring

Provides a superior bonnet seal.

4 Bronze Stem Nut

The nut is electrically isolated from the iron in the wedge for corrosion resistance. The nut is held tightly in place to resist stem binding.

5 Polymer Wedge Guide Bearing Caps

Provides a bearing surface between the encapsulated wedge and the interior epoxy coating, lowering operating torque and extending the service life of the valve.

6 Oversized, Full Port Opening, Smooth Waterway

The bottom of the waterway has no grooves or recesses to collect sediment or debris and compromise the seal. It accommodates full-sized shell cutters with ample clearance during tapping operations.

7 Mueller PRO-GARD® Epoxy Coating System

The superior fusion-bonded (thermosetting) powder epoxy covers the interior and exterior with a thickness of 10 mils nominal. The powder epoxy coating fully complies with ANSI/AWWA Standard C550.

8 Integral Legs

Flats cast in the bottom of the valve body let the valve stand upright in storage or during installation.

9 Available End Connections

FL x FL, MJ x FL, MJ x MJ, SL x SL, and FL x SL.

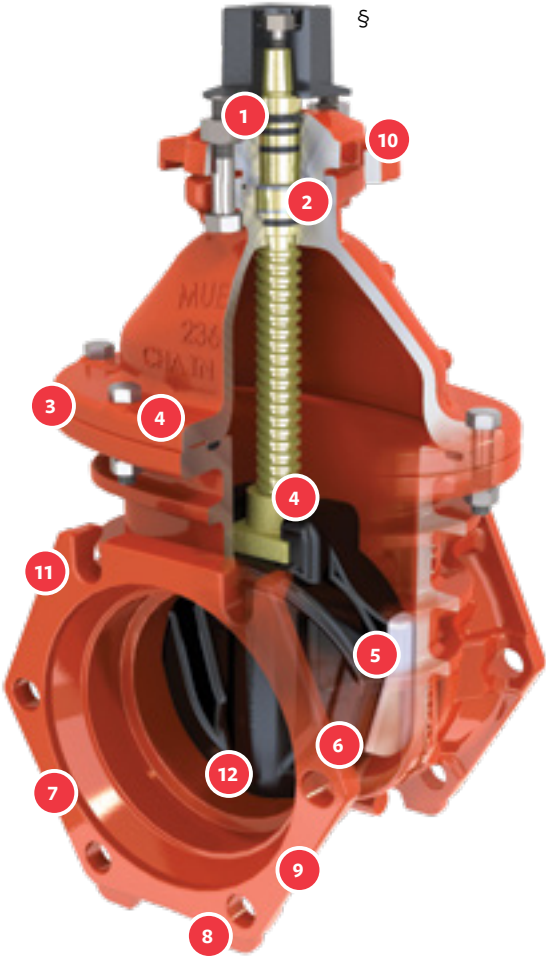

TRIPLE LISTED

Valve complies with:

- ANSI/AWWA C509 (3")
- ANSI/AWWA C515 (4" - 12")

Listed by Underwriters Laboratory Inc. and ULC

Approved by Factory Mutual Corp.

350 PSI RESILIENT WEDGE A-2361 GATE VALVES

Sizes 3" - 12"

10 Integrated Lift Lugs

The A-2361 resilient wedge gate valves also feature dual-purpose lifting lugs. The ductile iron lugs provide stability and alignment for the valve box. They instantly align the valve box (up to 8" valve size) and eliminate the need for a valve box adapter (standard 7½" I.D.). The lugs can accommodate straps or hooks, providing the contractor with options for lifting and installing while increasing site safety and ease of installation.

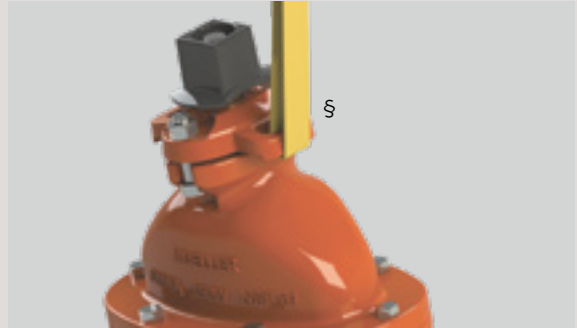

11 T-Head Bolt Retention

On all A-2361 resilient wedge gate valves with MJ flange connections, Mueller has designed a nesting area for T-head bolts to prevent rotation during pipe installation. This unique feature improves site safety, speeds installation, eliminates the need for special anti-rotation bolts, and results in a water-tight connection.

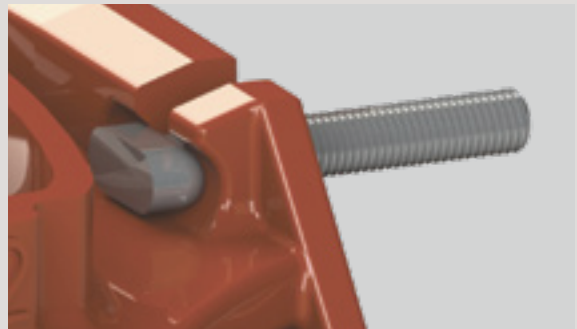

12 Self-Activating Wedge Seal

The shape of the iron wedge casting and the elastomeric encapsulation are specifically designed to provide positive stop, without over-stressing the elastomer or epoxy lining. The maximum operating torque at 350 psi is comparable to current values at 250 psi.



FORGED BRONZE STEM AND THRUST COLLAR MANUFACTURING PROCESS



BRONZE BAR STOCK



BAR STOCK IS CUT TO LENGTH

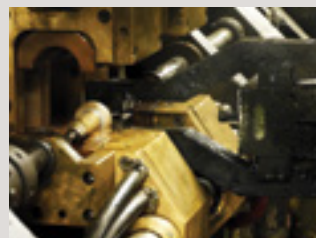

STEM IS ELECTRICALLY HEATED AND THRUST TOGETHER TO CREATE THE THRUST COLLAR



STEM THREADS AND THRUST COLLAR ARE ROBOTICALLY MACHINED AND SORTED

OUR PRODUCTS

Mueller has built its reputation on producing innovative water distribution products of superior quality – a reputation that is literally “on the line” every day throughout the world. Mueller products and those of its affiliates are used throughout the water system from the source to the consumer. We are committed to continuing research and development of new products and services to meet the growing needs of the water infrastructure industry. Mueller is the largest and only full-line supplier of potable water distribution products in North America and its markets continue to expand globally.

OUR PEOPLE

The capacity to deliver the widest array of products and stand behind those products to ensure your satisfaction is our strength. The success of Mueller is dependent upon the success of those who are involved, both inside and outside our company. Therefore, we feel our future is wholly dependent on long-term relationships with our employees, customers and suppliers. This is why we strive to be proactive and responsive to their needs, always looking for a “better way”. It’s an approach that has set us apart since 1857 and will assure our mutual achievement and prosperity in the future.

OTHER INNOVATIVE MUELLER PRODUCTS



MUELLER SUPER CENTURION 350™ HYDRANT

- 350 psig (2400 kPa/24 barg) working pressure, 700 psig (4800 kPa/48 barg) test pressure
- Sealed oil reservoir with automatic pressure lubrication
- Entire hydrant - epoxy coating inside and out inhibits corrosion
- Convenient, reversible main valve doubles service life
- Efficient hydraulic design provides maximum flow
- Certified to ANSI/NSF 61, ANSI/NSF 372
- 10-year limited warranty

For more information about Mueller or to view our full line of water products, please visit www.muellerwp.com or call Mueller customer service at 1.800.423.1323.

Mueller refers to one or more of Mueller Water Products, Inc. a Delaware corporation (“MWP”), and its subsidiaries. MWP and each of its subsidiaries are legally separate and independent entities when providing products and services. MWP does not provide products or services to third parties. MWP and each of its subsidiaries are liable only for their own acts and omissions and not those of each other. MWP brands include Mueller®, Echologics®, Hydro Gate®, Hydro-Guard®, Jones®, Krausz®, Mi.Net®, Milliken®, Pratt®, Pratt Industrial®, Singer®, and U.S. Pipe Valve & Hydrant. Please see muellerwp.com/brands to learn more.

© 2020 Mueller Water Products, Inc. All Rights Reserved. The trademarks, logos and service marks displayed in this document are the property of Mueller Water Products, Inc., its affiliates or other third parties. Products above marked with a section symbol (§) are subject to patents or patent applications. For details visit www.mwppat.com.