

# MUELLER

## R-2361+ RESILIENT WEDGE GATE VALVE

### OS&Y – PLUS: 14” – 24”/DN350 – DN600

#### PRODUCT FEATURES

- Outside Screw & Yoke (OS&Y), Standard-PLUS (+) Gate Valve.
- 14” – 24”/DN350 – DN600.\*
- Fusion Bonded Epoxy Coating covers all cast surfaces inside and out – 10 mils (250 µm) minimum. Meets requirements of AWWA/ANSI C550.
- Meets requirements of AWWA/ANSI C515 and is certified to ANSI/NSF 61 & 372.
- Ductile Iron wedge, symmetrical and fully encapsulated with molded rubber; no exposed iron.
- Polymer guide cap bearings on wedge guide.
- Everdur Bronze Stem.
- 316 Bolts, Nuts and Washers.
- 10-year limited warranty.
- 14” & 16”/DN350 & DN400: UL 262 Listed/FM 1120/1130 Approved 250 psig/17 barg.
- 18” – 24”/DN450 – DN600: UL 262 Listed 175 psig/12 barg, FM Approved 250 psig/17 barg.
- AWWA C-515 14” – 24”/DN350 – DN600: 250 psig/17 barg.
- Flange End drilling meets: ASME/ANSI B16.1, Class 125 and ANSI B16.42, Class 150 Flat Face (14” & 16”/DN350 & DN400 optional PN10, PN16 drilling).
- Fitted with End Covers as standard.

#### DIMENSIONS - INCHES (MM)

VALVE SIZE	A-CLOSED	AA-OPEN	B	C**
14”/DN350	49.13 (1248)	64.09 (1628)	15.06 (383)	24.92 (633)
16”/DN400	54.63 (1387)	71.19 (1808)	16.06 (408)	26.58 (675)
18”/DN450	67.82 (1723)	87.81 (2230)	17.00 (432)	30.50 (775)
20”/DN500	75.56 (1843)	94.35 (2396)	18.00 (457)	33.75 (857)
24”/DN600	82.42 (2093)	108.19 (2748)	20.00 (508)	39.50 (1003)

VALVE SIZE	ØD	ØETHRU Ø	ØF	G	VALVE SIZE	WEIGHT - LBS (KG)
14”/DN350	18.00 (457)	14.38 (365)	21.00 (533)	1.42 (36)	14”/DN350	775 (352)
16”/DN400	18.00 (457)	16.00 (406)	23.50 (597)	1.05 (27)	16”/DN400	960 (435)
18”/DN450	32.00 (813)	18.38 (467)	25.00 (635)	1.05 (27)	18”/DN450	1657 (752)
20”/DN500	32.00 (813)	20.38 (518)	27.50 (698)	1.78 (45)	20”/DN500	2239 (1016)
24”/DN600	32.00 (813)	24.38 (619)	32.00 (813)	1.25 (32)	24”/DN600	2899 (1315)

\*\*C dimension is the overall width of the bonnet flange.

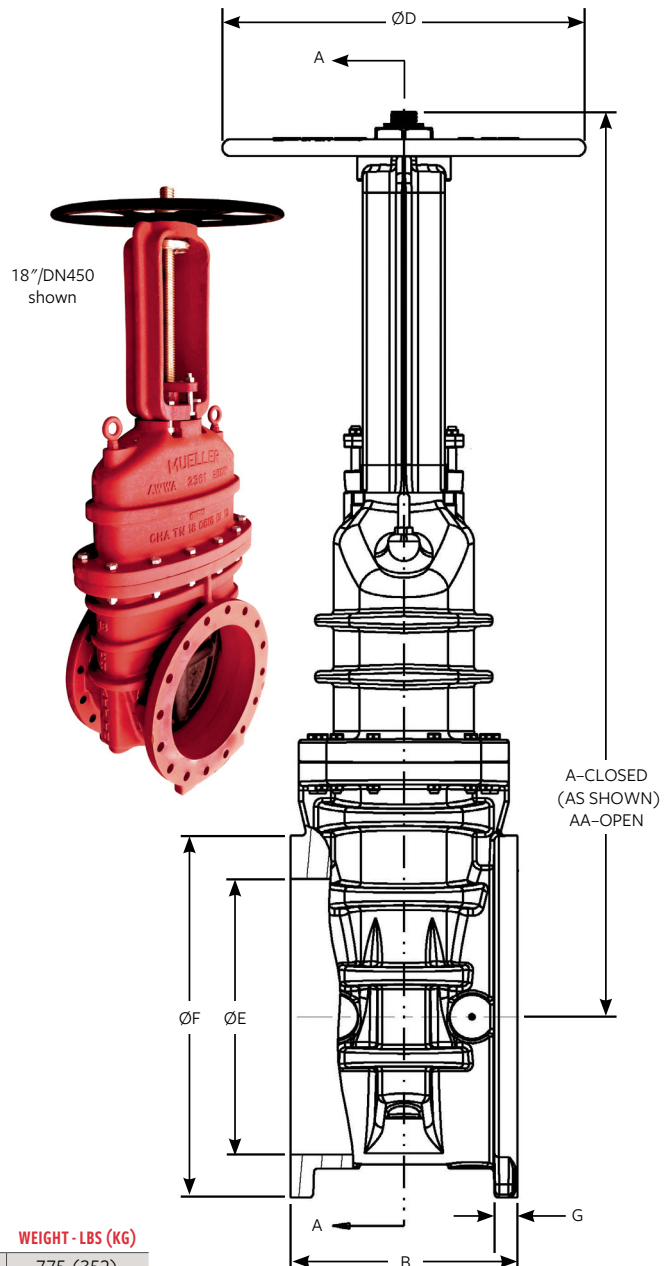

\*Resilient Wedge OS&Y Valves with similar performance and features, but different bonnet construction are available in 2” – 12”/DN50 – DN300 sizes, model R-2361+.

## 14" & 16"/DN350 & DN400 PARTS LIST

ID	PART NAME	MATERIAL
1	Cap Nut	Bronze ASTM B62
2	Handwheel	Cast Iron ASTM A126
3	Washer	Brass ASTM B36
4	Bush Nut	Bronze ASTM B584
5	Eyebolt	Forged Steel
6	Stem	Silicon Bronze ASTM B98 (C66100)
7	Wedge Nut	Bronze ASTM B62
8	Pin	Silicon Bronze ASTM B98
9	Gland Flange	Ductile Iron ASTM A536
10	Stem Packing	Lube Flax
11	Gland Bolt	See Note 1
12	Gland Nut	Silicon Bronze ASTM B98
13	Bonnet Bolt	316 Stainless Steel
14	Bonnet Nut	316 Stainless Steel
15	O-Ring	EPDM ASTM D2000
16	Wedge Rubber/Wedge Casting	EPDM ASTM D2000/Ductile Iron A536
17	Guide Cap	Acetal
18	Body	Ductile Iron ASTM A536
19	O-Ring	EPDM ASTM D2000
20	Bonnet	Ductile Iron ASTM A536
21	Yoke	Cast Iron ASTM A126
22	Cap Screw	316 Stainless Steel
23	Hex Nut	316 Stainless Steel

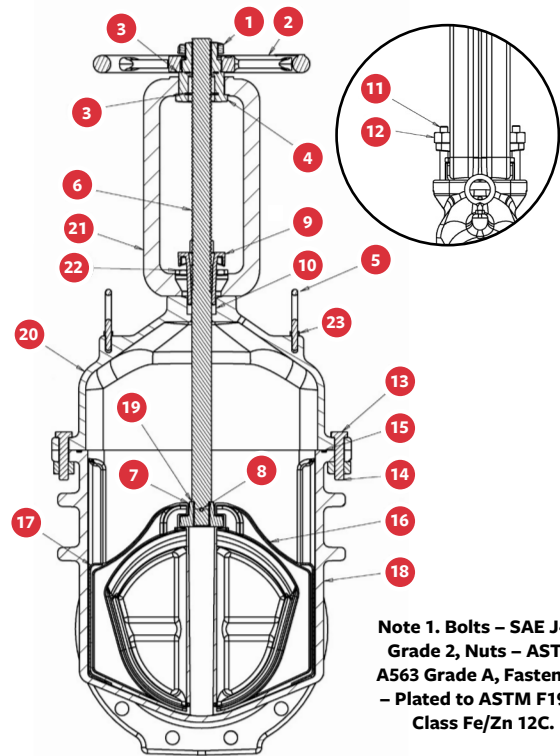

**Note 1. Bolts – SAE J429  
Grade 2, Nuts – ASTM  
A563 Grade A, Fasteners  
– Plated to ASTM F1941  
Class Fe/Zn 12C.**

## 18" - 24"/DN450 - DN600 PARTS LIST

ID	PART NAME	MATERIAL
1	Cap Nut	Bronze ASTM B62
2	Handwheel	Ductile Iron ASTM A536
3	Thrust Washer	Brass ASTM B36
4	Bush Nut	Bronze ASTM B584
5	Yoke	Ductile Iron ASTM A536
6	Stem	Silicon Bronze ASTM B763 (C99400)
7	Gland Flange	Ductile Iron ASTM A536
8	Gland Bolt	316 Stainless Steel
9	Gland Nut	Silicon Bronze ASTM B98
10	Stem Packing	Lube Flax
11	Bonnet Bushing	Bronze ASTM B62
12	Bushing O-Ring	EPDM ASTM D2000
13	Yoke Bolt	316 Stainless Steel
14	Yoke Nut	316 Stainless Steel
15	Eyebolt	Steel
16	Eyebolt Nut	Steel
17	Cap Screw	Carbon Steel ASTM A307
18	Bonnet	Ductile Iron ASTM A536
19	Bonnet Bolt	316 Stainless Steel
20	Bonnet Nut	316 Stainless Steel
21	Bonnet O-Ring	EPDM ASTM D2000
22	Stem O-Ring	EPDM ASTM D2000
23	Wedge Nut	Bronze ASTM B62
24	Wedge	EPDM/Ductile Iron ASTM A563
25	Guide Cap	Acetal
26	Body	Ductile Iron ASTM A536
27	Pin	Silicon Bronze ASTM B98
28	Pipe Plug	316 Stainless Steel

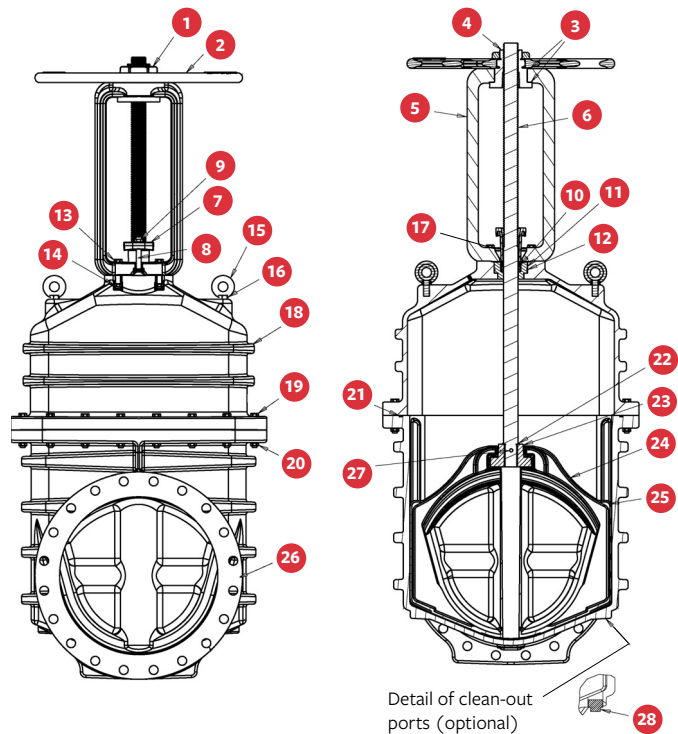

Detail of clean-out  
ports (optional)

For more information about us, or to view our full line of products, please visit [www.mueller-international.com](http://www.mueller-international.com) or call International Customer Service at:

UK: +44.1438.487410 Dubai: +971.4.214.6640 Singapore: +65.6816.3088 USA: +1.800.423.1323 | [International@muellerwp.com](mailto:International@muellerwp.com)

Mueller refers to one or more of Mueller Water Products, Inc. a Delaware corporation ("MWP"), and its subsidiaries. MWP and each of its subsidiaries are legally separate and independent entities when providing products and services. MWP does not provide products or services to third parties. MWP and each of its subsidiaries are liable only for their own acts and omissions and not those of each other. MWP brands include Mueller®, Echologics®, Hydro Gate®, Hydro-Guard®, Jones®, Krausz®, MiNet®, Milliken®, Pratt®, Pratt Industrial®, Singer®, and U.S. Pipe Valve & Hydrant. Please see [muellerwp.com/brands](http://muellerwp.com/brands) to learn more.

© 2020 Mueller Water Products, Inc. All Rights Reserved. The trademarks, logos and service marks displayed in this document are the property of Mueller Water Products, Inc., its affiliates or other third parties. Products above marked with a section symbol (§) are subject to patents or patent applications. For details visit [www.mwppat.com](http://www.mwppat.com).

