

**MUELLER**

# CONTROL VALVES

Real Solutions for Real Applications

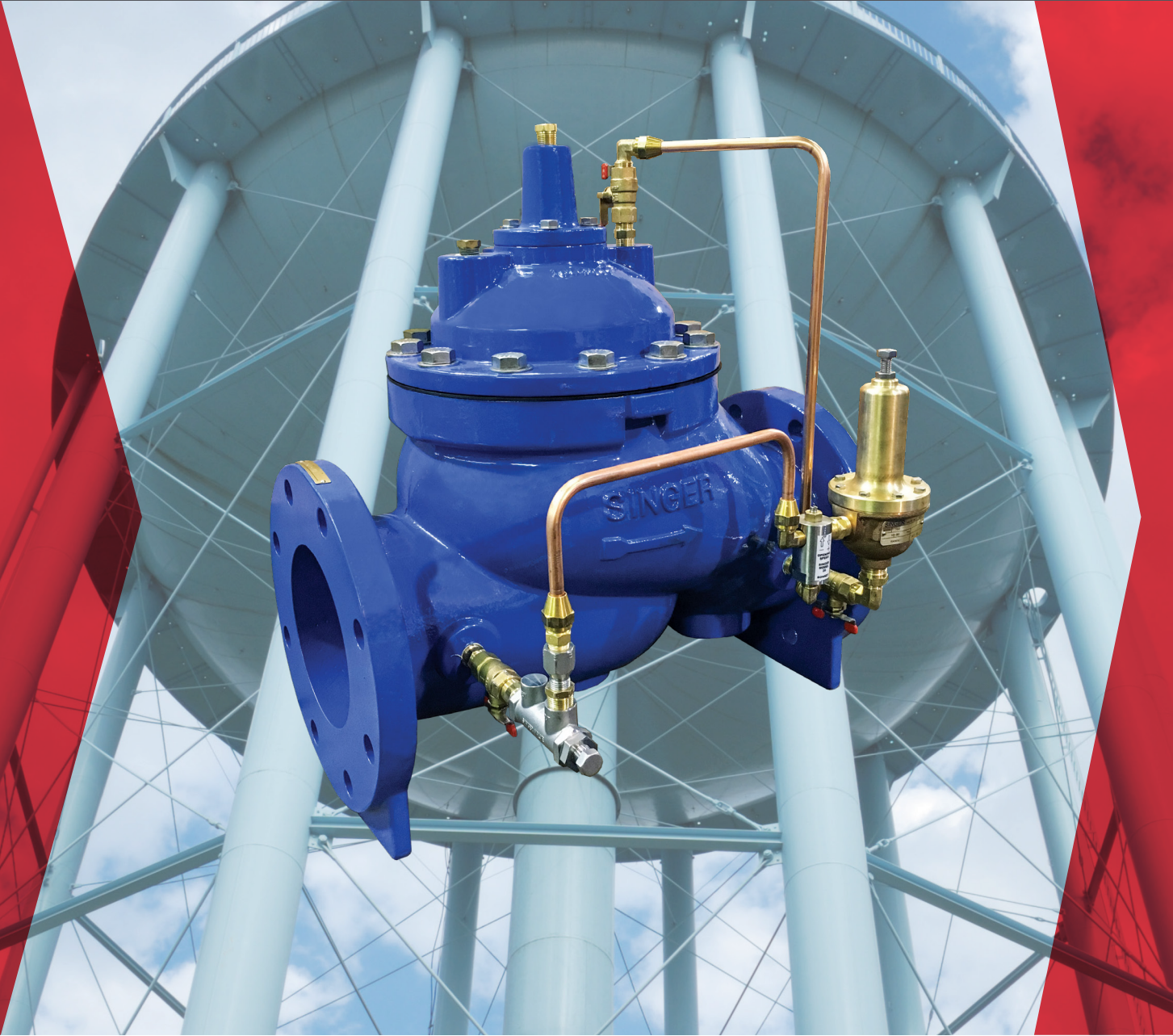

# LEVEL CONTROL VALVES

## Preventing Overflow in Tanks, Towers and Reservoirs

Our level control valves are the ideal solution for preventing overflow in tanks, towers and reservoirs. Repeatable, reliable operation each and every time! Our float valves directly control the maximum water level and our altitude valves control water levels from ground level. Because we hate overflow as much as you do.

### MODELS M106-A-TYPE 2/M206-A-TYPE 2 ONE-WAY FLOW ALTITUDE CONTROL VALVE

#### FEATURES

- No overflows - high level shut-off
- Superior repeatability
- Positive shut-off
- Easily serviceable at ground level

#### PRODUCT OVERVIEW

The M106-A-Type 2 and M206-A-Type 2 altitude control valves are based on the M106-PG or M206-PG main valve and are ideal for maintaining a preset maximum water level.

The valve functions as a two position control valve, either fully open or fully closed. The Type 2 valve allows normal forward flow to fill the reservoir to the maximum level and then closes drip-tight at the set-point. It opens to refill the tank once the level drops a fixed distance below the high water level.

*Note: This valve does not operate as a check valve to prevent reverse flow.*

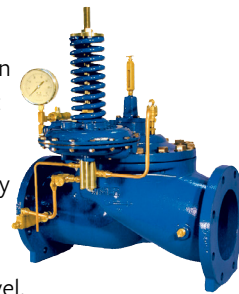

### MODELS M106-F-TYPE 4/M206-F-TYPE 4 MODULATING FLOAT VALVE

#### FEATURES

- Maintains relatively constant level
- Automatic compensation for level draw-down
- Standard integral damping reduces hunting
- Drip-tight at high level shut-off
- Low supply pressure options

#### PRODUCT OVERVIEW

The M106-F-Type 4 and M206-F-Type 4 modulating float valves are based on the M106-PG or M206-PG main valve. They are ideal for balancing the inflow and outflow demand into the reservoir and maintaining level at the designated maximum.

The valve closes drip-tight at the maximum level and modulates to maintain the tank level. The float pilot is remotely installed at the high level in the reservoir tank. Pilot connections to the main valve are connected in the field. As the reservoir level drops the main valve is opened proportionally to increase the filling rate. Movement of the main stem alters the size of the closing restriction, interrupting the tendency of the valve to hunt.



### MODELS M106-F-TYPE 5/M206-F-TYPE 5 NON-MODULATING FLOAT VALVE

#### FEATURES

- No overflow, drip-tight close
- Adjustable draw-down
- Easily adjustable level settings
- Low supply pressure options

#### PRODUCT OVERVIEW

The M106-F-Type 5 and M206-F-Type 5 non-modulating float valves are based on the M106-PG or M206-PG main valve. It is ideal for allowing normal forward flow to fill water reservoirs to a desired high level and where the pilot and valve of the reservoirs are easily accessible.

The valve functions as a two position valve, either open or closed. The valve remains closed when the reservoir level drops, until the float reaches the predetermined adjustable minimum reservoir level. The F-Type 5 valve then opens to refill the reservoir and closes tightly when high water level is achieved.



# PRESSURE REDUCING VALVES

## Maintain a Uniform Downstream Pressure

When faced with extreme pressures or anything in between, our pressure reducing valves maintain a uniform downstream pressure. Regardless of the problem, regardless of the application, our valves perform under pressure.

### MODELS M106-PR/M206-PR PRESSURE REDUCING VALVE

#### FEATURES

- Ideal for maintaining accurate downstream pressure
- Responds quickly and effectively

#### PRODUCT OVERVIEW

The M106-PR and M206-PR series pressure reducing valves are based on the M106-PG or M206-PG main valves.

The pilot valves sense the downstream pressure through a connection at the valve outlet. Under flowing conditions, the pilot reacts to small changes in pressure to control the valve position by modulating the pressure above the diaphragm. The downstream pressure is maintained virtually steady at the pilot set-point. In typical pressure reducing applications, the standard port model M206-PR is often the best selection.



### MODELS M106-RPS/M206-RPS PRESSURE RELIEF/PRESSURE SUSTAINING VALVE

#### FEATURES

- Maintains system upstream pressure by relieving excess overpressure
- Ensures minimum upstream pressure for critical user(s)

#### PRODUCT OVERVIEW

The M106-RPS and M206-RPS pressure relief valves are based on the M106-PG and M206-PG main valves. The 81-RP pilot senses the upstream pressure through a connection to the valve inlet.

The valve and pilot remain closed until the inlet pressure exceeds the pilot setting. The valve opens rapidly to relieve damaging overpressure and closes smoothly at an adjustable speed, when the pressure returns below the set-point. The upstream pressure is limited to the pilot set-point.

The M106-RPS and M206-RPS pressure sustaining valves control upstream pressure. Under flowing conditions, the pilot reacts to small changes in pressure to control the valve position. Should upstream pressure fall below the setpoint, the valve will close or modulate to ensure the set-point is maintained.

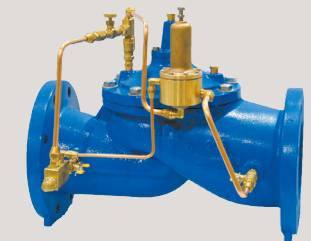

### MODELS M106-SC/M206-SC SOLENOID CONTROL VALVE

#### FEATURES

- Positive, drip-tight shut-off
- Simple, on-off operation
- Globe or angle style body
- Multiple solenoid voltages available

#### PRODUCT OVERVIEW

Models M106-SC and M206-SC solenoid control valves are based on the model M106-PG or M206-PG main valve. The solenoid control valve provides on-off position operation.

The solenoid either admits inlet pressure into the main valve operating chamber or releases pressure from the operating chamber. The pilot system is usually piped to discharge at the valve outlet, but can be piped to discharge to drain (atmosphere). This valve is available either with the main valve closed when the solenoid is de-energized (NC - Normally Closed) or with the main valve open when the solenoid is de-energized (NO - Normally Open). (NC or NO refers to the main valve, not the solenoid.)



# SINGLE ROLLING DIAPHRAGM

## Unparalleled Low Flow Stability

### WHY USE SINGER™ SRD TECHNOLOGY

Mueller introduced the Singer revolutionary rolling diaphragm design to the automatic control valve industry in 1983. Although rolling diaphragm technology has been used in railway air brakes for more than a century, Mueller is the only pilot operated control valve company to adapt the technology for control valves. With water loss management a global priority and the accompanying need for precise pressure management, Mueller's pioneering design and engineering is leading the way.

Since the first Mueller rolling diaphragm control valve in 1983 to the introduction of the rolling diaphragm technology on 6"/DN150 mm, 8"/DN200 mm in addition to our existing range from 10"/DN250 mm to 36"/DN900 mm, Mueller has been steadfast in its dedication to offer precise pressure management. The advantage of rolling diaphragm technology in contrast to flat diaphragm, or traditional piston-style valves, is the incredible stability throughout a complete range of flows.

Mueller's rolling diaphragm can control pressures with flows as high as any product offering in the marketplace today; however, the difference is on extremely low flows. During the night most distribution systems have low flow and higher pressures. Traditional automatic control valves will often have seat chatter. At low flows the valve will chatter and vibrate. As a result, a smaller bypass valve is needed to control the lower flows.

A Mueller rolling diaphragm pressure reducing valve will provide stable, reliable and precise pressure control from maximum to virtually zero flow without the complication of additional low-flow bypass valves.

### FEATURES

- Maintains a constant diaphragm surface area over the full stroke of the valve
- Low and high flow stability
- EPDM
- Stable and longer life - dependable performance
- Eliminates the need for a low flow bypass - saves space and reduces maintenance
- Smaller bonnet diameter, lighter and safer for maintenance
- Faster response times to changing pressures due to reduced bonnet volume

### SMOOTH. STEADY. PRECISE.

Our Single Rolling Diaphragm (SRD) Pressure Reducing Valves provide smooth, steady and precise pressure control from maximum to virtually zero flow without the need for low-flow bypass valves. By eliminating the seat chatter at low flows, the SRD avoids injecting small pressure pulses into the piping, which, over time, may increase leakage, losses or pipe bursts.

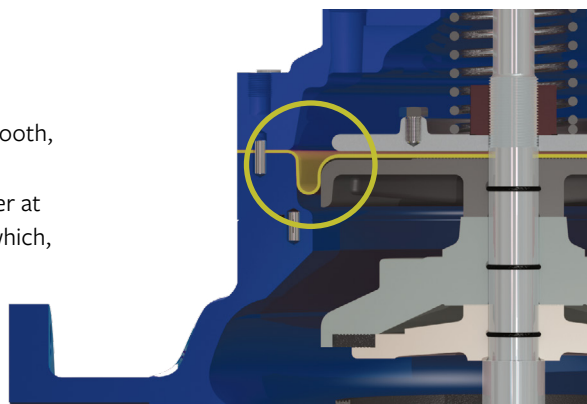

**For more information about Mueller or to view our full line of water products, please visit [www.muellerwp.com](http://www.muellerwp.com) or call Mueller customer service at 1.800.423.1323.**

Mueller refers to one or more of Mueller Water Products, Inc. a Delaware corporation ("MWP"), and its subsidiaries. MWP and each of its subsidiaries are legally separate and independent entities when providing products and services. MWP does not provide products or services to third parties. MWP and each of its subsidiaries are liable only for their own acts and omissions and not those of each other. MWP brands include Mueller®, Echologics®, Hydro Gate®, Hydro-Guard®, Jones®, Krausz®, Mi.Net®, Milliken®, Pratt®, Pratt Industrial®, Singer®, and U.S. Pipe Valve & Hydrant. Please see [muellerwp.com/brands](http://muellerwp.com/brands) to learn more.

Copyright © 2020 Mueller Water Products, Inc. All Rights Reserved. The trademarks, logos and service marks displayed in this document are the property of Mueller Water Products, Inc., its affiliates or other third parties. Products above marked with a section symbol (§) are subject to patents or patent applications. For details visit [www.mwppat.com](http://www.mwppat.com).