



**VALVE &
HYDRANT**

R-UFP2 RESILIENT WEDGE GATE VALVE

OS&Y: 2" - 12" / DN50 - DN300

PRODUCT FEATURES

- Outside Screw & Yoke (OS&Y).
- Iron Body, Bonnet, and Yoke.
- Mueller Pro-Gard® Fusion Bonded Epoxy Coating covers all cast surfaces inside and out - 10 mils(250µ) nominal. Meets requirements of AWWA/ANSI C550.
- Iron wedge, symmetrical and fully encapsulated with molded rubber; no exposed iron.
- Polymer cap bearings on wedge guides resist wear and provide easy operation.
- Bi-directional flow.
- 10-year limited warranty.
- 2" - 12" / DN50 - DN300: 300psig/21barg UL/FM WP, 600psig/42barg TP.
- UL 262 listed, FM 1120 / 1130 approved.
- Flange End drilling meets: ANSI B16.1, Class 125 and ANSI B16.42, Class 150 Flat Face. Optional PN10, PN16 drilling.
- Other connection configurations also available, Groove x Groove; Groove x Flange (DN50/2" - DN300/12") and Thread x Thread (DN50/2", DN65/2½" & DN80/3"), please request further details.

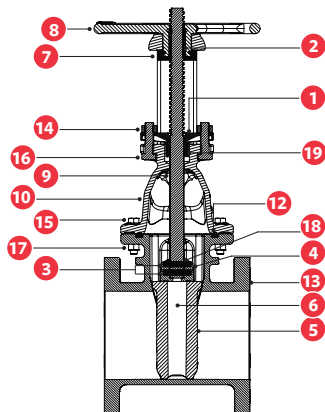

PARTS LIST

ID	PART NAME	MATERIAL
1	Gland Flange	Ductile Iron ASTM A536
2	Handwheel insert	Brass ASTM B16
3	Stem Pin	303 Stainless Steel
4	Wedge Nut	Ductile Iron ASTM A536
5	Encapsulated Wedge	Rubber - EPDM ASTM D2000 Wedge - Ductile Iron ASTM A536
6	Guide Cap	Acetal
7	Collar	Hot Rolled Steel - ASTM A36
8	Handwheel	Ductile Iron ASTM A536
9	Stem	431 Stainless Steel
10	Bonnet/Yoke	Ductile Iron ASTM A536
12	Bonnet O Ring	Rubber - EPDM ASTM D2000
13	Body	Ductile Iron ASTM A536
14	Gland Nut	Silicon Bronze ASTM B98
15	Bonnet Bolt	316 Stainless Steel ASTM F593
16	Gland Bolt	316 Stainless Steel ASTM F593
17	Bonnet Nut	316 Stainless Steel ASTM F594
18	O Ring	Rubber - EPDM ASTM D2000
19	Stem Packing	Lubricated Flax

*STEM PACKING INFORMATION

Valve Size	2" /DN50, 2 ½" /DN65, 3" /DN80	4" /DN100	6" /DN150	8" /DN200	10" /DN250	12" /DN300
Part No. / Quantity	175972 / 4	176477 / 4	170712 / 4	175937 / 4	175975 / 4	170749 / 3
Size - inches (mm)	¼ (6) x 3 ⅝ (92)	¼ (6) x 4 ¼ (108)	⅝ (8) x 4 ¾ (121)	⅝ (8) x 5 ⅛ (130)	⅝ (8) x 5 ½ (133)	⅜ (10) x 6 ⅜ (161)



DIMENSIONS - INCHES (MM)

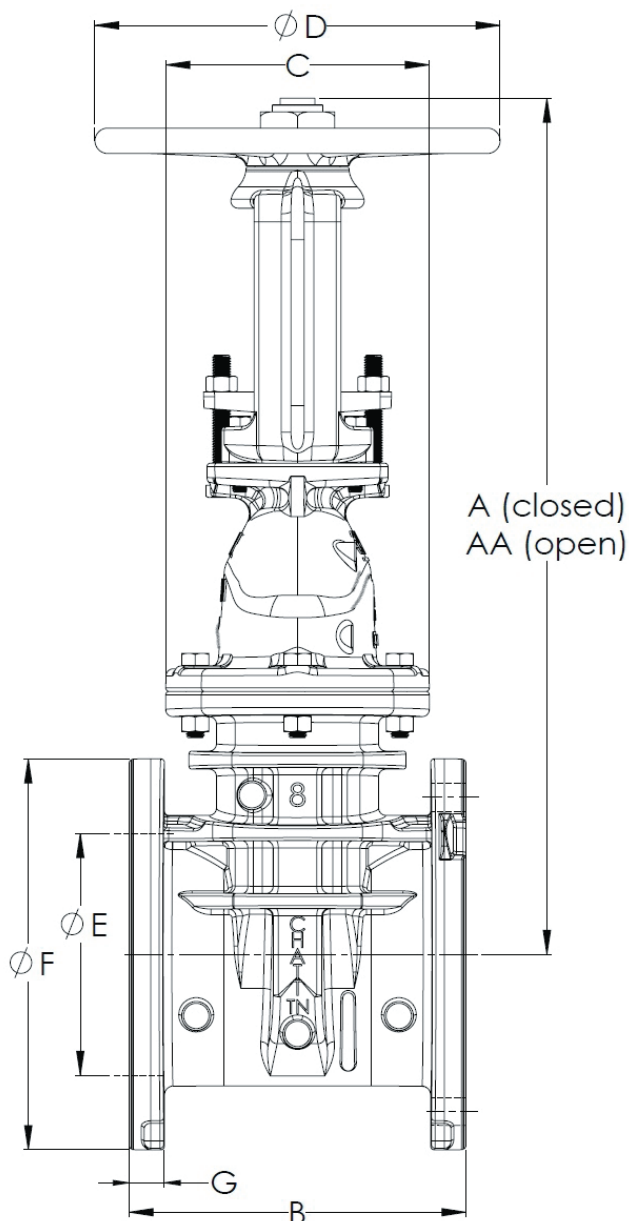

VALVE SIZE	A-CLOSED	AA-OPEN	B	C*
2" / DN50	13.08 (332)	15.63 (397)	7.00 (178)	7.02 (178)
2 1/2" / DN65	15.55 (395)	19.1(485)	7.50 (191)	8.63 (219)
3" / DN80	15.3 (389)	18.85 (479)	8.00 (203)	8.63 (219)
4" / DN100	17.79 (452)	22.24 (565)	9.00 (229)	10.79 (274)
6" / DN150	22.67 (576)	29.2 (742)	10.50 (267)	13.50 (343)
8" / DN200	28.94 (735)	37.56 (954)	11.50 (292)	16.36 (416)
10" / DN250	34.96 (888)	45.57 (1157)	13.00 (330)	19.99 (508)
12" / DN300	40.08 (1018)	52.72 (1339)	14.00 (356)	21.00 (533)

VALVE SIZE	ØD	ØETHRU Ø	ØF	G
2" / DN50	5.00 (127)	2.30 (58)	6.00 (152)	0.68 (17)
2 1/2" / DN65	7.00 (178)	2.80 (71)	7.00 (178)	0.75 (19)
3" / DN80	7.00 (178)	3.30 (84)	7.50 (191)	0.80 (20)
4" / DN100	10.00 (254)	4.31 (109)	9.00 (229)	1.03 (26)
6" / DN150	12.00 (305)	6.30 (160)	11.00 (279)	1.07 (27)
8" / DN200	14.00 (356)	8.30 (211)	13.50 (343)	1.19 (30)
10" / DN250	16.00 (406)	10.30 (262)	16.00 (406)	1.29 (33)
12" / DN300	16.00 (406)	12.30 (312)	19.00 (483)	1.35 (34)

*C dimension is the overall width of the bonnet flange.

OPTIONAL PLUGS

VALVE SIZE	R-USP2 MAX. TAP SIZE	OPTION NO.	TAP SIZE
2" / DN50	3/4" (19)	0008	1/2" (13)
2 1/2" / DN65	1/2" (13)	0054	3/4" (19)
3" / DN80	1/2" (13)	0062	1" (25)
4" / DN100	3/4" (19)	0355	1 1/4" (32)
6" / DN150	1" (25)	0070	1 1/2" (38)
8" / DN200	1 1/4" (32)	0366	2" (50)
10" / DN250	1 1/4" (32)		
12" / DN300	2" (50)		

WEIGHT - LB. (KG)

Valve Size	2" / DN50	2 1/2" / DN65	3" / DN80	4" / DN100	6" / DN150	8" / DN200	10" / DN250	12" / DN300
Weight	36 (16)	59 (27)	60 (27)	91 (41)	151 (68)	221 (100)	368 (167)	524 (238)

For more information about us, or to view our full line of products, please visit www.mueller-international.com or call International Customer Service at:

UK: +44.1438.487410 Dubai: +971.4.214.6640 Singapore: +65.6816.3088 USA: +1.800.423.1323 | International@muellerwpp.com

Mueller refers to one or more of Mueller Water Products, Inc. a Delaware corporation ("MWP"), and its subsidiaries. MWP and each of its subsidiaries are legally separate and independent entities when providing products and services. MWP does not provide products or services to third parties. MWP and each of its subsidiaries are liable only for their own acts and omissions and not those of each other. MWP brands include Mueller®, Echologics®, Hydro Gate®, Hydro-Guard®, Jones®, Krausz®, Mi.Net®, Milliken®, Pratt®, Pratt Industrial®, Singer®, and U.S. Pipe Valve & Hydrant. Please see muellerwpp.com/brands to learn more.

© 2020 U.S. Pipe Valve & Hydrant, LLC. All Rights Reserved. The trademarks, logos and service marks displayed in this document are the property of Mueller Water Products, Inc., its affiliates or other third parties. Products above marked with a section symbol (§) are subject to patents or patent applications. For details, visit www.mwppat.com. These products are intended for use in potable water applications. Please contact your Mueller Sales or Customer Service Representative concerning any other application(s).