

HYMAX[®]

a **MUELLER** brand

HYMAX GRIP[®] RESTRAINT END TYPE SIZES 4"-12" FOR:

- **A-2361 RESILIENT WEDGE GATE VALVE**
- **SUPER CENTURION[®] 250 FIRE HYDRANT**

INSTALLATION INSTRUCTIONS



WARNING:

CAUTION: This product is not intended for use on natural gas piping or any other type of gas piping. This could result in escaping gas which could ignite and cause property damage, serious injury or death.



IMPORTANT

THE HYMAX GRIP RESTRAINT is a stab-on type restraint ready for customer installation and approved for use with metal and plastic pipes. No disassembly of the end ring is allowed. Do not loosen the bolt nor the (2) connecting bolts closing the end ring assembly.

LUBRICATION OF PIPES (EXCLUDING PVC AND HDPE PIPES) all rough-surfaced pipes must be lubricated with a water-based gasket lubricant in order to achieve a proper seal. Do not lubricate PVC or HDPE pipe surface.

DO NOT LUBRICATE BOLTS AND NUTS as bolts are pre-lubricated with a MAG (Molecular anti-galling) coating and grease. Supplemental greasing of bolts or nuts voids the manufacturer's warranty.

TIGHTEN BOLT TO THE TORQUE VALUE provided on the tag in one continuous step. Tighten (1) bolt to the minimum torque value provided on the label. The minimum torque requirement must be achieved prior to any pressurization.

USE A TORQUE WRENCH TO TIGHTEN THE BOLT a torque wrench will assure a proper torque has been applied. Do not use other tools to tighten the HYMAX Grip Restraint's bolt!

PIPE STIFFENERS OR INSERTS ARE REQUIRED when used on HDPE pipes

- HDPE pipe expands and contracts with changes in temperature and exerts large pull-load forces. ΔT for HDPE pipe is the change in temperature that the restraint can withstand when installed on HDPE pipe.
- In accordance with the Plastic Pipe Institute requirements, a stiffener is required when restraining HDPE pipe. To maximize performance and meet ratings in the product specification (Form 14373) a full cylinder stiffener shall be used.
- HDPE ratings shown are for buried, below ground use only (Vault applications require additional considerations).

CAST IRON PIPES The HYMAX Grip Restraint has been tested on CI pipe. Due to the variety and conditions of CI pipe in the field, pressure ratings cannot be guaranteed. Installed correctly, on good condition CI pipe, the restraint can perform up to 250psi. Please see table on the product tag for applicable OD ranges.

DO NOT USE The HYMAX Grip Restraint on AC or FRP Pipes. Review product specification (Form 14373) for applicable ratings and pipe types.

WARNING: LACK OF PROPER TORQUING OF THE BOLT MAY CAUSE BODILY HARM, CAUSE THE PRODUCT TO NOT MEET THE PRODUCT SPECIFICATION PERFORMANCE, AND SHALL VOID THE MANUFACTURER'S WARRANTY.

MUELLER

PREPARE PRODUCT AND PIPE FOR INSTALLATION:

1

CLEAN AND DESCALE THE PIPE

Make sure that:

- The pipe is clear from debris
- The pipe is not out of round and is free of scratches, dents, flats and defects
- Lubricate rough-surface pipes with a water-based gasket lubricant. Do not lubricate PVC or HDPE pipes.
- Ensure that the HYMAX Grip Restraints are centered. If they are not, please contact your local distributor for return and replacement.
- Reference back of the product tag

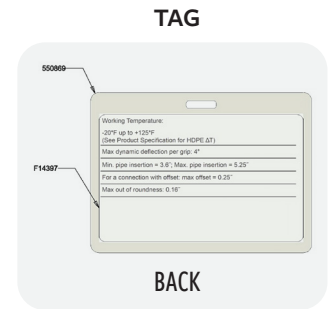
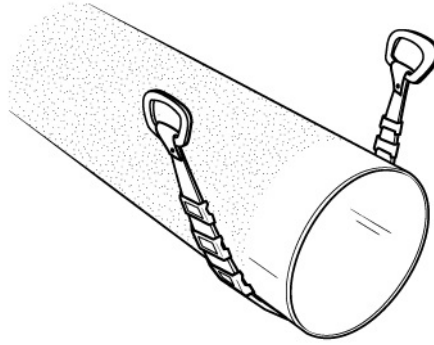

2

MEASURE THE PIPE TWICE

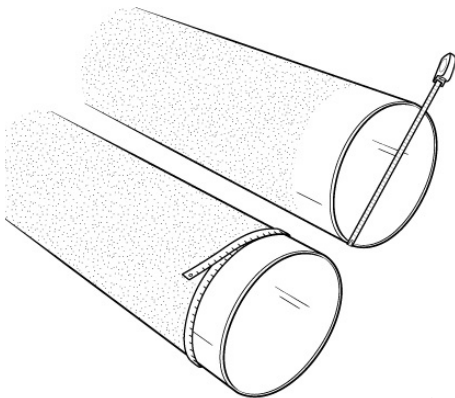

Make sure that:

The HYMAX Grip Restraint size range (as indicated on the front of the product's tag) will fit the pipe(s) properly

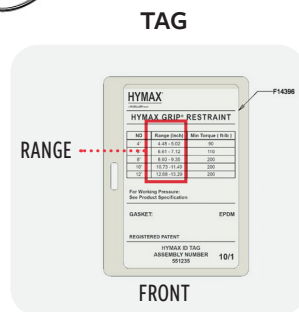

3

MARK EACH PIPE END FOR MINIMUM PIPE INSERTION DISTANCE

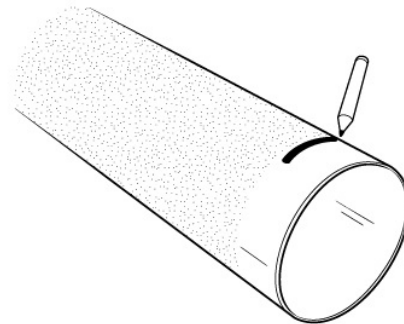

Mark pipe end to the minimum required stab depth as indicated on the back of the product tag.

PREPARE PRODUCT AND PIPE FOR INSTALLATION:

4

POSITION THE GATE VALVE OR HYDRANT FOR INSTALLATION

Make sure that:

- Ensure gate valve or hydrant is supported in the ditch and ready for the pipe to be inserted
- Stab pipe into HYMAX Grip Restraint per marks made in step 3
- Ensure that the pipes and product are well supported as the HYMAX Grip Restraint is not designed to carry the weight of the pipes

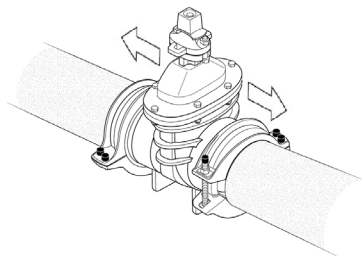
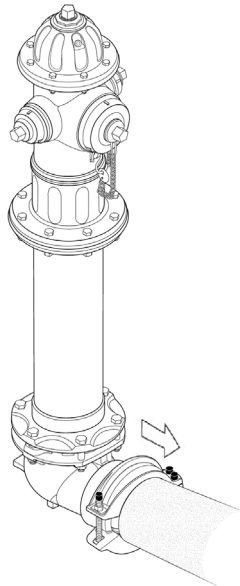

5

TIGHTEN

Tighten the HYMAX Grip Restraint's bolt to the correct torque as indicated on the front of the product tag. Double-check torque.

TAG

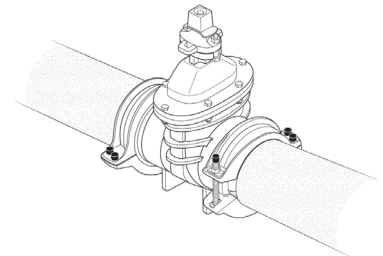
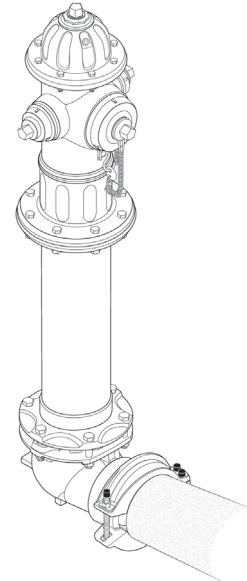
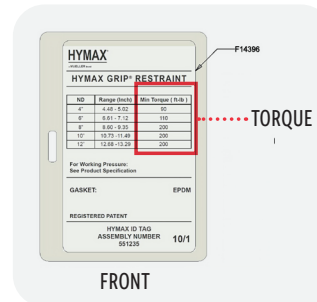

6

PRESSURIZE

Pressurize the line and check for leaks. If any leakage is evident, reduce the pressure in the line and increase bolt torque by up to 50%. Verify again no leaks are evident along the seal.

Intentionally Left Blank

For more information about Mueller or to view our full line of water products, please visit www.hymaxusa.com or call HYMAX customer service at 1.800.423.1323.

Mueller refers to one or more of Mueller Water Products, Inc. a Delaware corporation ("MWP"), and its subsidiaries. MWP and each of its subsidiaries are legally separate and independent entities when providing products and services. MWP does not provide products or services to third parties. MWP and each of its subsidiaries are liable only for their own acts and omissions and not those of each other. MWP brands include Mueller®, Echologics®, Hydro Gate®, Hydro-Guard®, HYMAX®, iZO®, Jones®, Krausz®, Mi.Net®, Milliken®, Pratt®, Pratt Industrial®, Singer®, and U.S. Pipe Valve & Hydrant. Please see muellerwp.com/brands and krauszusa.com to learn more.

© 2022 Mueller Co., LLC. All Rights Reserved. The trademarks, logos and service marks displayed in this document are the property of Mueller Co., LLC., its affiliates or other third parties. Products above marked with a section symbol (§) are subject to patents or patent applications. For details, visit www.mwppat.com. These products are intended for use in potable water applications. Please contact your Mueller Sales or Customer Service Representative concerning any other application(s).

F14454 1/22

