

Installation Instructions for PE or Copper Tubing

This fitting is intended for use with water and tubing made from polyethylene plastic and/or Type K, soft annealed copper, which is made in accordance with AWWA and/or ASTM specifications.

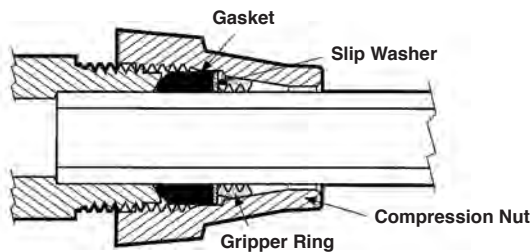

Shown Before Tightening

WARNING: The safe and reliable performance of this product requires correct installation only on the specific type of tubing or pipe described in the product literature, and which has been manufactured and verified by the installer to comply with the dimensional and physical performance criteria as set forth in the pertinent AWWA/ASTM standard for the tubing/pipe. Improper installation or use of this product on non-standard material could result in failure of the connection with the potential for serious bodily injury and/or property damage.

Installation

1. End of tubing or pipe must be round, free of burrs and clean, but does not require beveling.

IMPORTANT: A rigid, solid tubular stainless steel liner must be used inside the end of polyethylene plastic to prevent it from collapsing as connection is tightened, and to provide support to allow the gasket in the connection to establish a reliable seal.

2. For polyethylene plastic tubing, push appropriate size of liner in until flare on liner rests solidly against end of tubing as shown.

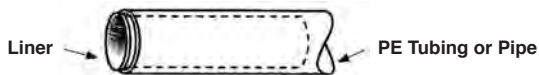

3. Insert tubing into body of fitting until it contacts the stop inside fitting.

NOTE: If pipe is out-of-round, remove the nut assembly (which includes the nut, gripper ring, slip washer and gasket) from the fitting body, without removing the parts inside, and slide the nut assembly onto the tubing or pipe end.

4. For 3/4" and 1" sizes: tighten the nut 1-1/2" to 2-1/2 turns past hand tight. For 1-1/2" and 2" sizes: tighten the nut 3 to 3-1/2 turns past hand tight.

WARNING: Do not use a compressible medium such as air to check for water tightness – doing so could result in an explosive failure causing serious bodily injury or property damage.

5. Pressure test for leakage before backfilling in accordance with ASTM D2774, latest edition.

IMPORTANT: This connection is not intended for reuse unless gasket, slip washer and gripper ring are replaced. Replacements are available from supplier.

Installation Instructions for PE or Copper Tubing (continued)

Installation without Pipe Stop

This fitting is made without a mechanical stop to position the pipe or tubing when it is inserted into the connection. Ensure the pipe or tubing is inserted as shown in the following illustration to the depth given in the chart.

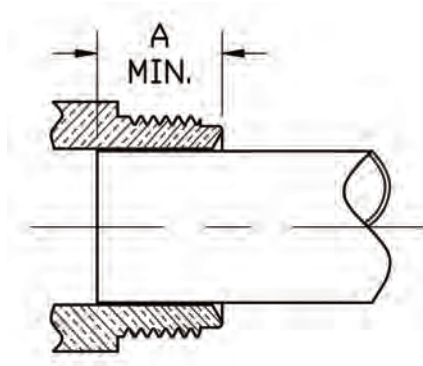

Pipe/Tubing Insertion Depth

Connection Type	Size	Dim. A
CTS	1/2"	11/16"
	5/8"	3/4"
	3/4"	3/4"
	1"	7/8"
	1-1/4"	1-1/8"
	1-1/2"	1-3/16"
	2"	1-1/4"
IPS	3/4"	1"
	1"	3/4"
	1-1/4"	1-7/16"
	1-1/2"	1-7/16"
	2"	1-1/2"

Phone: (800) 423-1323

Products above marked with a section symbol (§) are subject to patents or patent applications. For details, visit www.mwppat.com. By deviating from the above listed instructions, you will void any product warranty and release Mueller Co. and its affiliated entities from any and all liability associated with the installation or use of this product. For details on the product's warranty, terms, and conditions, please visit www.muellercompany.com.

© 2016 Mueller Co., LLC. All rights reserved.

Form 12669 04/16