

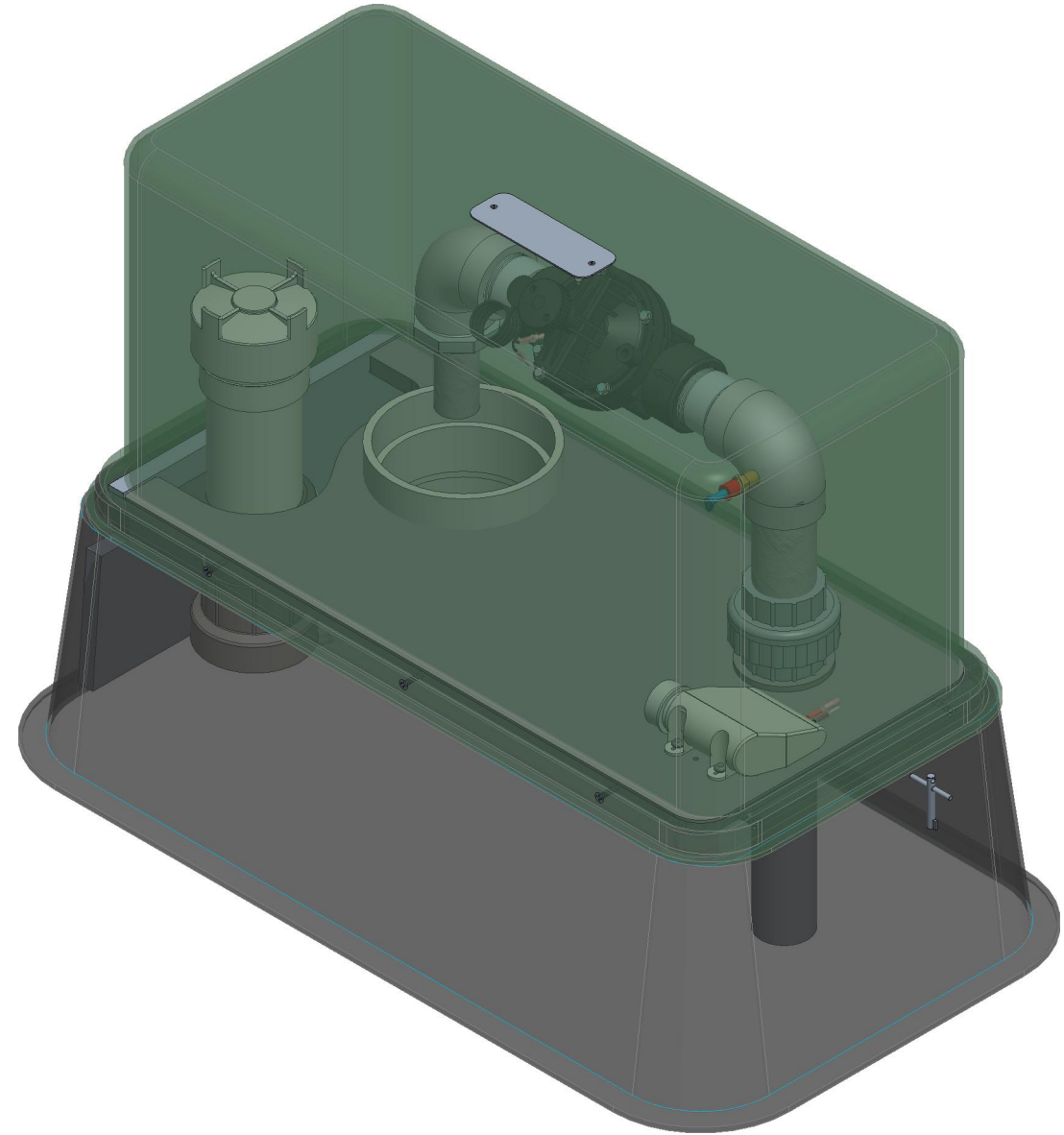

SCALE 0.175



SCALE 0.150

FW200

UL APPROVED NSF/ANSI 372					
DR. BY	AOD	6/15/21	UNLESS OTHERWISE NOTED		THIRD ANGLE PROJECTION
CHKR			BREAK CAST CORNER(S)---		 
ENGR			BREAK MACH CORNER(S)---		
MGR			TOLERANCES		PURCH.
MFG			UNLESS OTHERWISE NOTED		FINISH
TOOL			LINEAR	ANGULAR	REF. NO.
FDRY			± .005	±	SCALE
DESCR.					STK. NO.
MUELLER		MODEL:	FW200	NUMBER	FW200