

ITEM	DESCRIPTION	REQ'D
1	3/4" FULLPORT BALL ANGLE METER VALVE	1
2	3/4" DUEL ASSE CHECK VALVE	1
3	15" SHELL SUB-ASSEMBLY	1
4	PVC STABILIZING BRACKET	2
5	3/4" HEX NUT	4
6	METER JUMPER	1
7	RISER SUB-ASSEMBLY	1
8	250B20200 w/ HANDLE	1
* 9	282920 METER LID	1

* OPTIONAL

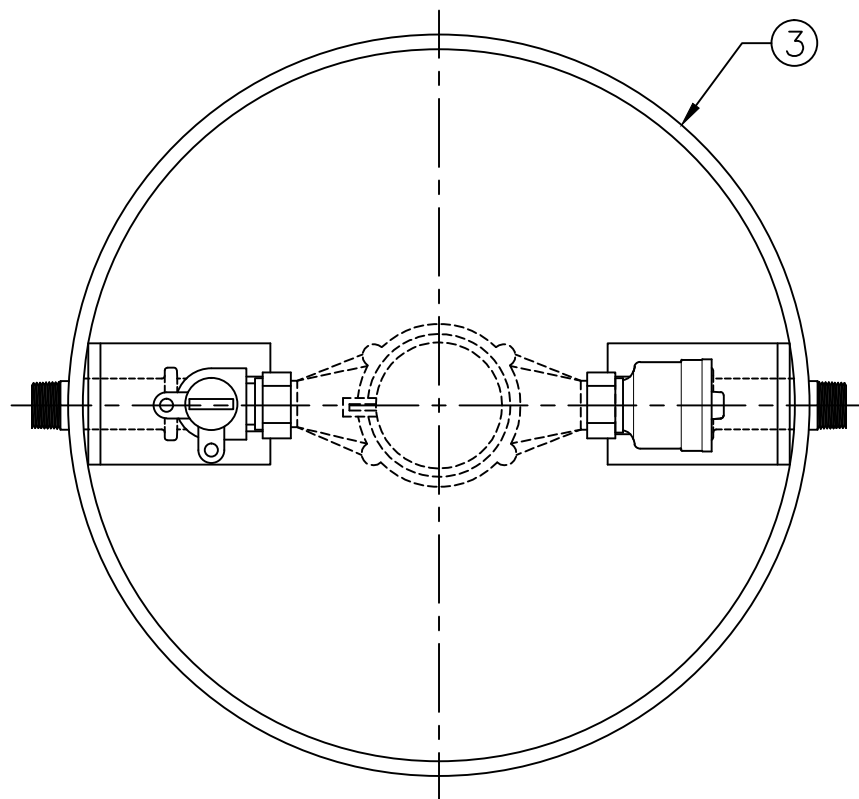

TOP VIEW

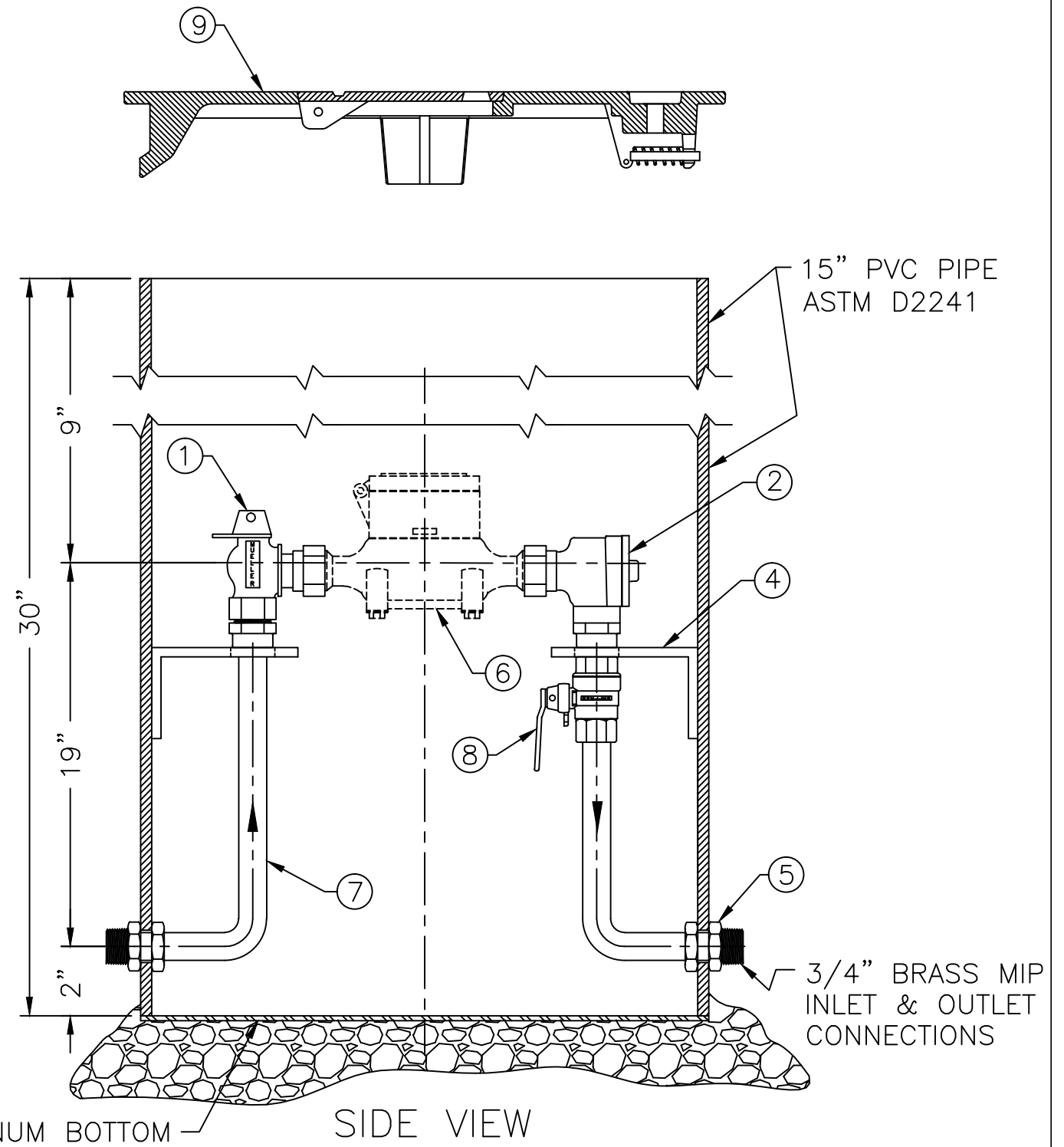

ATTACHED ALUMINUM BOTTOM

SIDE VIEW

203RS1530FSAN

DRFT'R	SMC	1-4-04	THIRD ANGLE PROJECTION	REF. NO.	SCALE
CHK'R					1:4
E.O. NUMBER				STOCK No.	
			DESCR.	REV.	NUMBER
			15" EZ SETTER RIGID SINGLE METER PIT	203RS1530FSAN	203RS1530FSAN
					SHEET 1 OF 1

REV.	DESCRIPTION	REF.	DRFT'R	CHK'R	APP	DATE