

203AT157284FBBS000044N

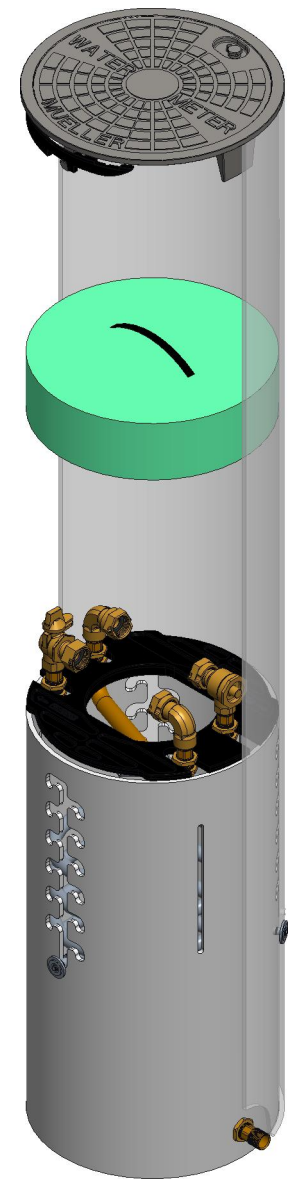
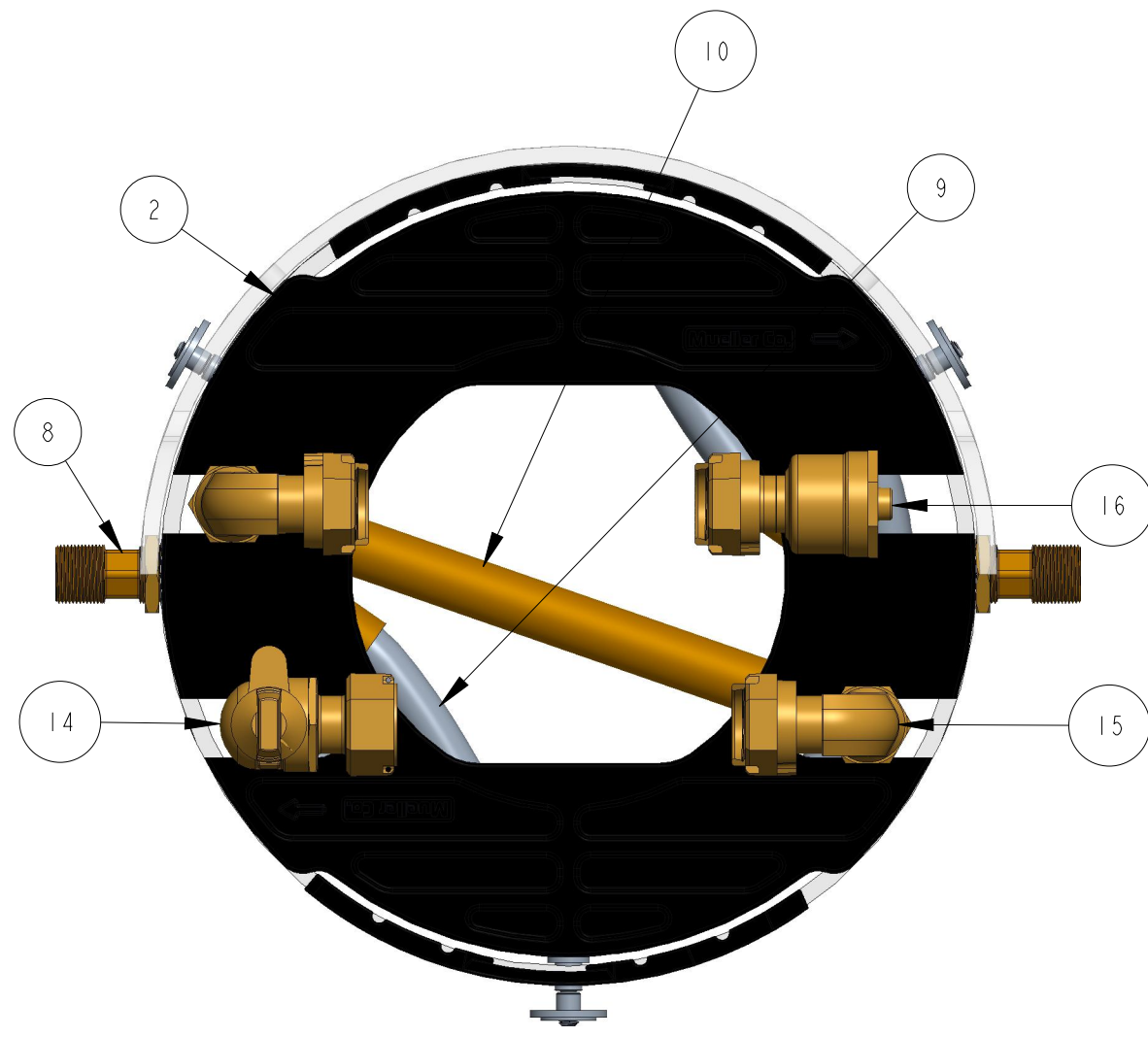
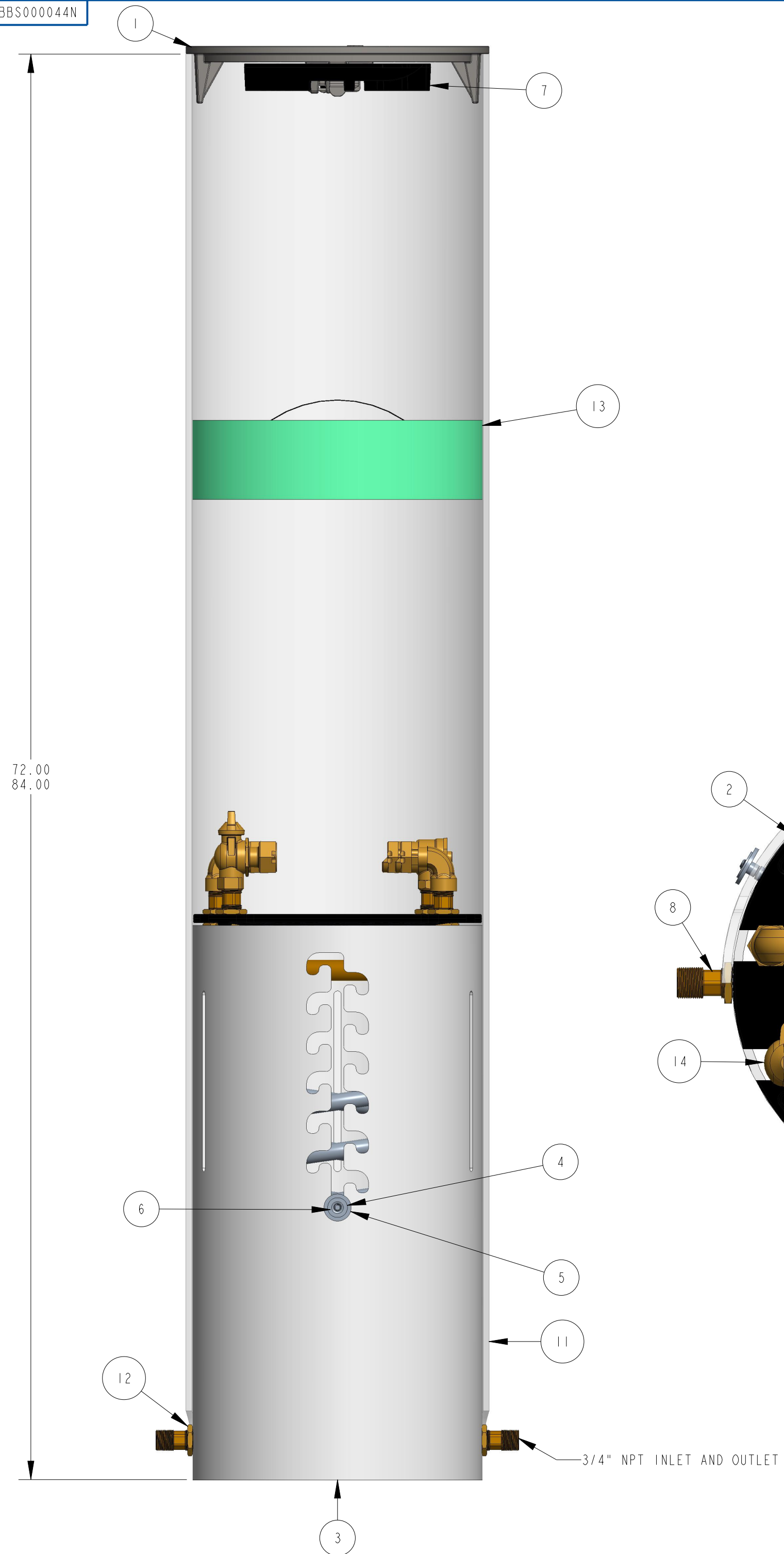

ITEM NO	PART NUMBER	QTY	DESCRIPTION
1	282924	1	CAST IRON LID (SOLD SEPERATELY)
2	311967	1	15-30 ABS PLATFORM
3	545214-1512	1	14" INSIDE CARTRIDGE - 12" RISE
4	545216	3	T-NUT
5	545217	3	STAINLESS STEEL WASHER
6	545218	3	3/8-16 SHOULDER BOLT
7	548357_151N	2	15" & 18" UNIVERSAL BRACKET
8	700013_REVE	4	3/4" HOSE CONNECTOR
9	700035-1590	2	3/4" COIL PART
10	700293	1	3/4" U-BAR
11	790000-1572	1	15" ADJUSTA-COIL ASSEMBLY 72"-84"
12	790006	12	3/4" HEX NUT
13	790022	1	15" INSULATION PAD (SOLD SEPARATELY)
14	215B2426550N	1	5/8" X 3/4" FULL PORT BALL VALVE W/ PLAIN NUT
15	215HI4210	2	5/8" X 3/4" METER COUPLING (SWIVEL NUT)
16	215HI4244	1	5/8" X3/4" DUAL CHECK VALVE

OPTION CODE: 44
 *FOR WATTS SM3-Z6 SUPPLIED BY CUSTOMER

DR. BY	AOD	5/10/21	UNLESS OTHERWISE NOTED	THIRD ANGLE PROJECTION	C.B. NO.
CHKR			BREAK CAST CORNER(S)---		
ENGR			BREAK MACH CORNER(S)---	PURCH.	FINISH
MGR			TOLERANCES	REF. NO.	SCALE
MFG			UNLESS OTHERWISE NOTED	STR. NO.	
TOOL			LINEAR	ANGULAR	
FDRY			±	±	
MAT'L:					
Mueller Co.		DESCR.	NUMBER		
		5/8" X 3/4" ADJUSTABLE TANDEM METER PIT 15" DIAMETER X 74-84" DEPTH LOW LEAD BRASS	203AT157284FBBS000044N		