

215B5020-R6A00N

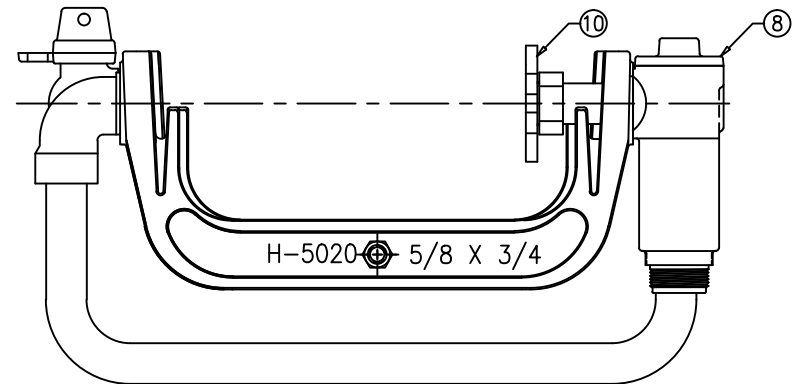
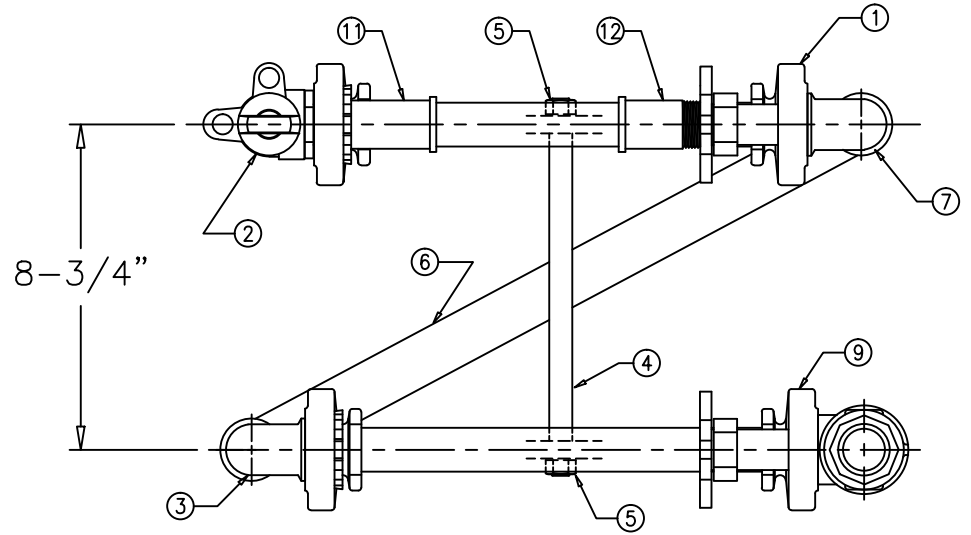

ITEM	PT. NO.	DESCRIPTION	QTY.
1	526478	METER BAR	1
2	203NB24273R	BALL ANGLE METER VALVE	1
3	215NH1420700	WATER METER COUPLING	1
4	527369	SPACER BAR	1
5	311633	HEX NUT	2
6	529077	U-BAR FOR 110 CONNECTION	1
7	203NH1420700	WATER METER COUPLING	1
8	215NH14466-A-05	VERTICAL CANISTER CHECK VALVE W/ TEST DRAIN	1
9	526479	METER BAR	1
* 10		EXPANSION HAND WHEEL	2
11	SUB. ASS'Y		
12	682235	EXTENSION TAILPIECE	2

* ORDERED SEPARATELY

A/C		(MILLIMETER)
		INCH
INITIAL RELEASE		
DRFT'R	CJD	
CHK'R		
APP	JMG	
E.O. NUMBER		

TOLERANCES - MACHINING
 UNLESS OTHERWISE NOTED

BREAK EDGES **FINISH SURFACES**

MACH. .006/.016 125

FRACTIONS **DECIMALS** **ANGLES**

±1/64 2 PL ±.025 ±1°

3 PL ±.010

THIRD ANGLE PROJECTION	
PURCH.	FINISH
REF. NO.	SCALE
	NONE
STK. NO.	

B	BILL OF MATERIAL CORRECTED		JMG		JMG	1-8-01
REV.	DESCRIPTION	REF.	DRFT'R	CHK'R	APP	DATE



MAT'L.
 DESCR. TANDEM 5000 LOW LEAD
 5/8 X 3/4 X 3/4 IRON METER YOKE

REVISION	NUMBER
B	215B5020--R6A00N
SHEET 1 OF 1	