

ITEM NO	PART NUMBER	QTY	DESCRIPTION	MATERIAL
1	504041	4	HEX CAP SCREW	YELLOW BRASS ASTM B134 ALLOY C26000
2	532208_REV-C	1	STRETCH BASE TRAY CASTING	CAST IRON ASTM A48 CLASS 25
3	532209_REV-B	1	STRETCH BOX UPPER SECTION	CAST IRON ASTM A48 CLASS 25
4	544622	4	MACHINE SCREW	STAINLESS STEEL
5	544623	4	HEX NUT	STAINLESS STEEL
6	544631	4	1/4" LOCK WASHER 304SS	STAINLESS STEEL
7	250G15527N	1	3/4" IPS GRIP JOINT X 3/4" MIP SERVICE FITTING	LEAD FREE BRASS ALLOY ASTM B584 C89833/C87850
8	250H14234N	1	3/4" HANDWHEEL EXPANSION	LEAD FREE BRASS ALLOY ASTM B584 C89833/C87850
9	311930E	1	Two-Stage Backflow-Prevention Valve	Low Lead Cast Bronze ASTM B 584
10	508563E	1	3/4" INSIDE IP THREAD OUTLET	LEAD FREE BRASS ALLOY ASTM B584 C89833/C87850
11	532211REVD	1	CAST IRON METER BOX LID	CAST IRON ASTM A48 CLASS 25
12	683021N	1	INLINE IRON METER BOX BALL VALVE	LEAD FREE BRASS ALLOY ASTM B584 C89833/C87850

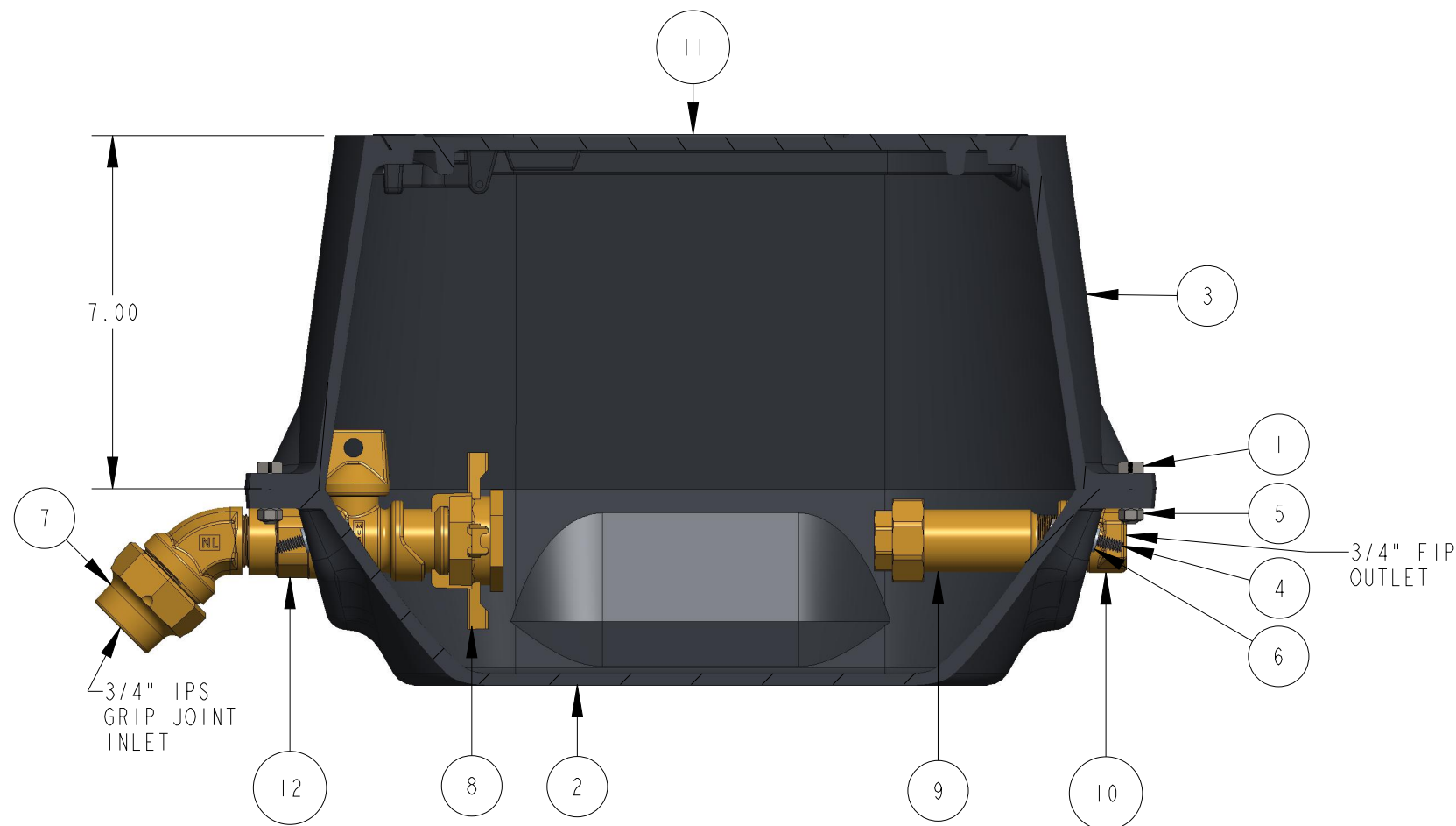

OPTION CODE 16:

*G15527N FITTING ON INLET

DR. BY	AOD	3/22/23	UNLESS OTHERWISE NOTED		THIRD ANGLE PROJECTION	C.B. NO.
CHKR			BREAK CAST CORNER(S)---			
ENGR			BREAK MACH CORNER(S)---			PURCH.
MGR			TOLERANCES		REF. NO.	PATT. NO.
MFG			UNLESS OTHERWISE NOTED		SCALE	
TOOL			LINEAR	ANGULAR	NONE	
FDRY			±	±	STK. NO.	

MAT'L:		DESCR. 5/8" X 3/4" CAST IRON METER BOX 7" HEIGHT LEAD FREE BRASS		NUMBER 234G2462--C-16N

234G2462--C-16N