

| ITEM NO | PART NUMBER   | QTY | DESCRIPTION                            | MATERIAL                                      |
|---------|---------------|-----|--|---|
| 1       | 089541        | 1   | TOUCH READ LID                         | CAST IRON                                     |
| 2       | 504041        | 4   | HEX CAP SCREW                          | YELLOW BRASS ASTM B134 ALLOY C26000           |
| 3       | 508551_PART - | 1   | BASE TRAY                              | CAST IRON                                     |
| 4       | 508552_PART   | 1   | 7" BOX UPPER SECTION                   | CAST IRON                                     |
| 5       | 544622        | 4   | MACHINE SCREW                          | STAINLESS STEEL                               |
| 6       | 544623        | 4   | HEX NUT                                | STAINLESS STEEL                               |
| 7       | 544631        | 4   | 1/4" LOCK WASHER 304SS                 | STAINLESS STEEL                               |
| 8       | 250HI4234N    | 1   | 3/4" HANDWHEEL EXPANSION               | LEAD FREE BRASS ALLOY ASTM B584 C89833/C87850 |
| 9       | 333HI5428N    | 1   | 1" CTS X 3/4" MIP SERVICE FITTING      | LEAD FREE BRASS ALLOY ASTM B584 C89833/C87850 |
| 10      | 508563E       | 1   | 3/4" INSIDE IP THREAD OUTLET           | LEAD FREE BRASS ALLOY ASTM B584 C89833/C87850 |
| 11      | 680506N       | 1   | 5/8"X3/4" OR 3/4" METER VALVE ASSEMBLY | LEAD FREE BRASS ALLOY ASTM B584 C89833/C87850 |

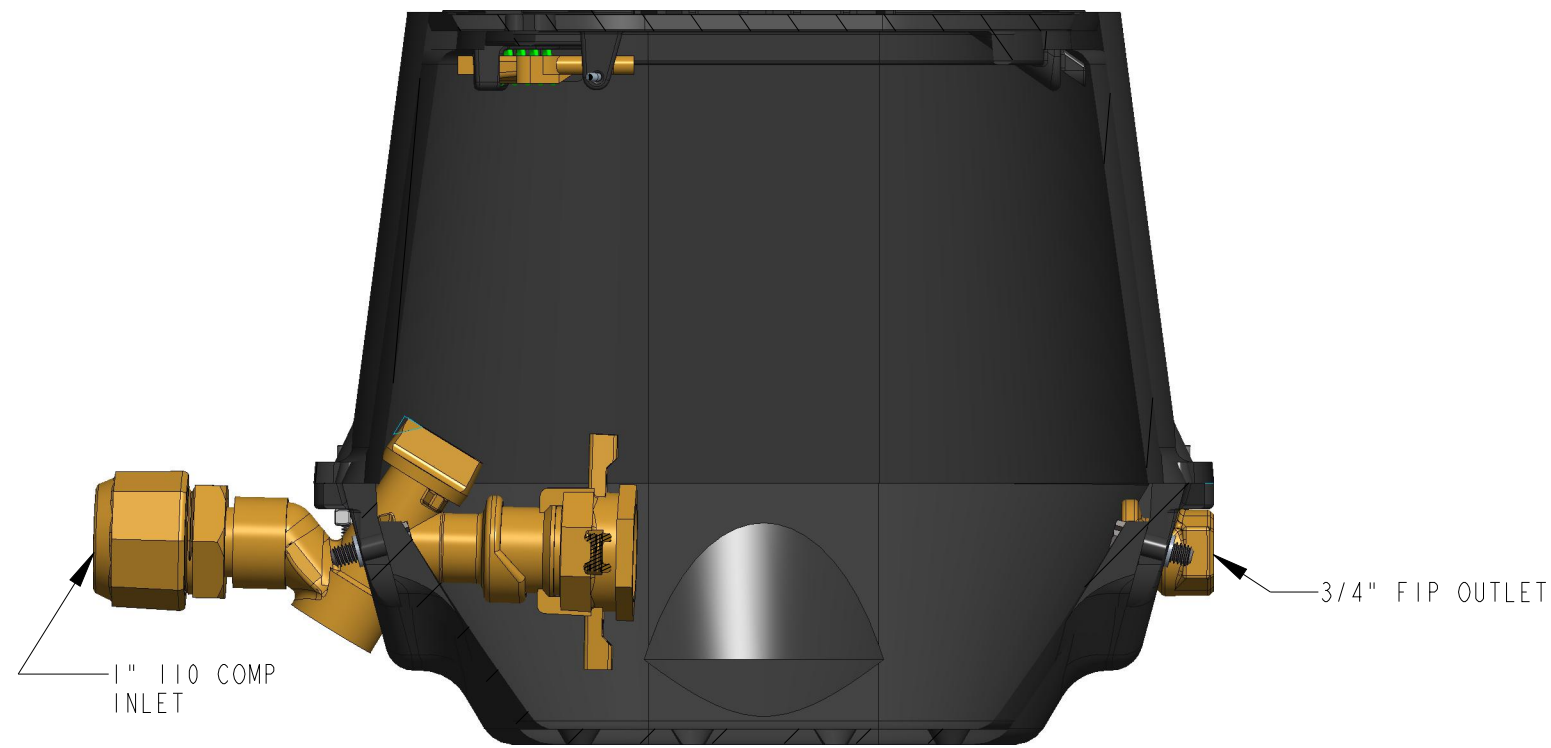

234HI452--K--N

|        |     |         |   |         |                        |        |                |           |
|--------|-----|---------|---|---------|------------------------|--------|----------------|-----------|
| DR. BY | AOD | 3/13/23 | UNLESS OTHERWISE NOTED  |         | THIRD ANGLE PROJECTION |        | C.B. NO.       |           |
| CHKR   |     |         | BREAK CAST CORNER(S)---                                       |         |                        |        |                |           |
| ENGR   |     |         | BREAK MACH CORNER(S)---                                       |         |                        | PURCH. | FINISH         | PATT. NO. |
| MGR    |     |         | TOLERANCES  |         | REF. NO.               | SCALE  |                |           |
| MFG    |     |         | UNLESS OTHERWISE NOTED  |         |                        | NONE   |                |           |
| TOOL   |     |         | LINEAR  | ANGULAR | STK. NO.               |        |                |           |
| FDRY   |     |         | ±   | ±       |                        |        |                |           |
| MAT'L: |     |         |   |         |                        |        |                |           |
|        |     |         | DESCR. 5/8"X3/4" CAST IRON METER BOX 7" HEIGHT LOW LEAD BRASS |         |                        |        | NUMBER         |           |
|        |     |         |   |         |                        |        | 234HI452--K--N |           |