

ITEM NO	PART NUMBER	QTY	DESCRIPTION
1	311929_REVC	1	7" STRETCH BOX PLASTIC UPPER
2	532208_REV-C	1	STRETCH BASE TRAY CASTING
3	544862	1	6"X13" PLASTIC LID
4	089805N	1	5/8" X 3/4" OR 3/4" METER VALVE
5	250HI4234N	1	3/4" HANDWHEEL EXPANSION
6	333HI5428N	1	1" CTS X 3/4" MIP SERVICE FITTING
7	508563E	1	3/4" INSIDE IP THREAD OUTLET

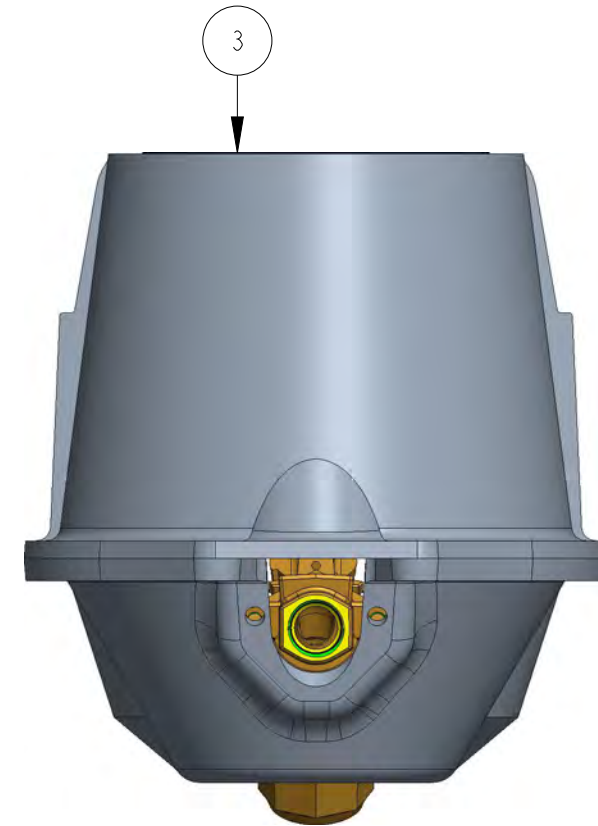
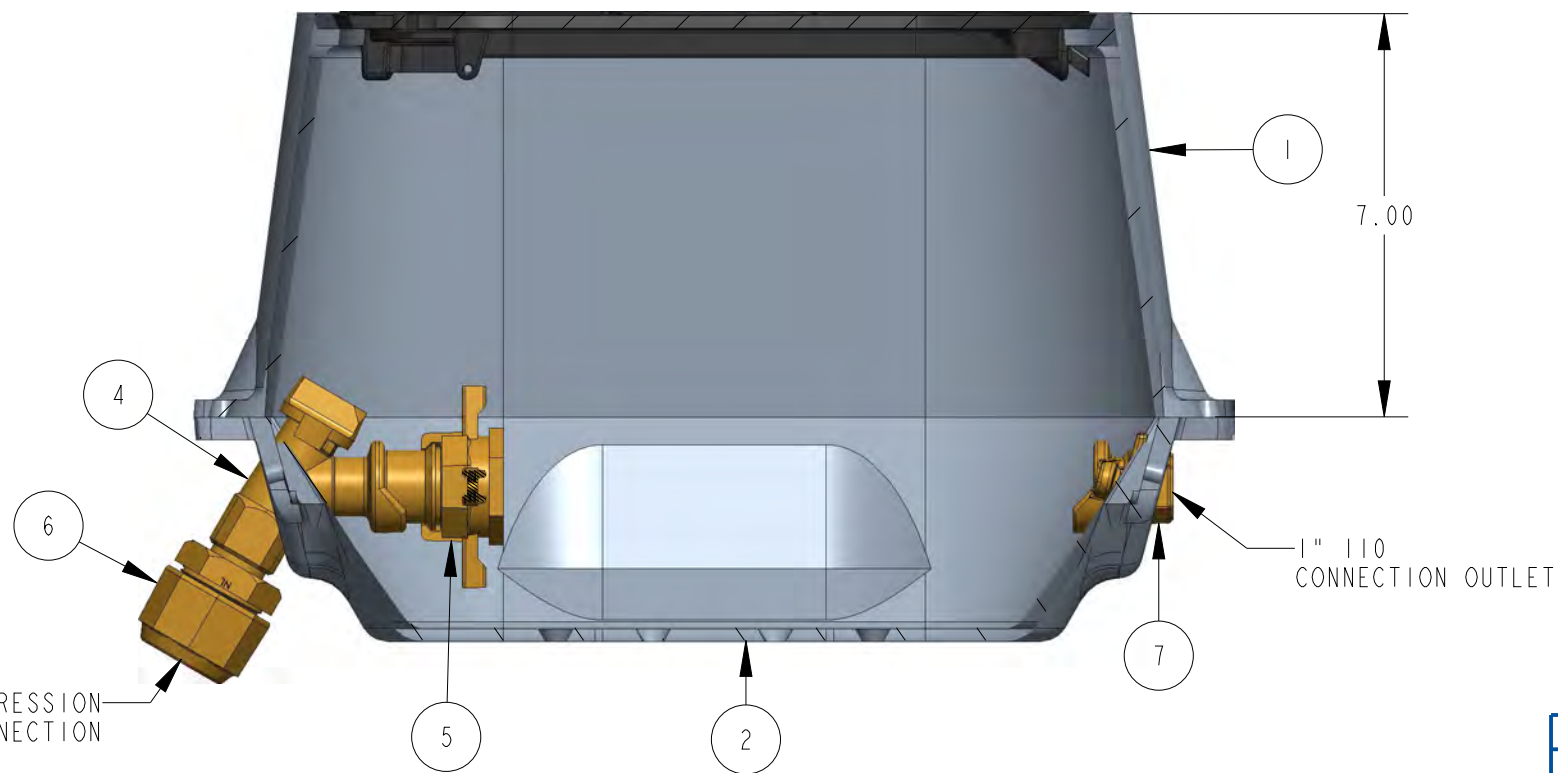

1" 110 COMPRESSION CONNECTION

1" 110 CONNECTION OUTLET

DR. BY	AOD	2/16/22	UNLESS OTHERWISE NOTED		THIRD ANGLE PROJECTION	C.B. NO.
CHKR			BREAK CAST CORNER(S)---			
ENGR			BREAK MACH CORNER(S)---			
MGR			TOLERANCES		PURCH.	FINISH
MFG			UNLESS OTHERWISE NOTED		REF. NO.	SCALE
TOOL			LINEAR	ANGULAR	NONE	
FDRY			±	±	STK. NO.	
MAT'L:						
MUELLER		DESCR.	5/8"X3/4" CAST IRON STRETCH METER BOX LOW LEAD BRASS		NUMBER	234HI46IPPJ---N