

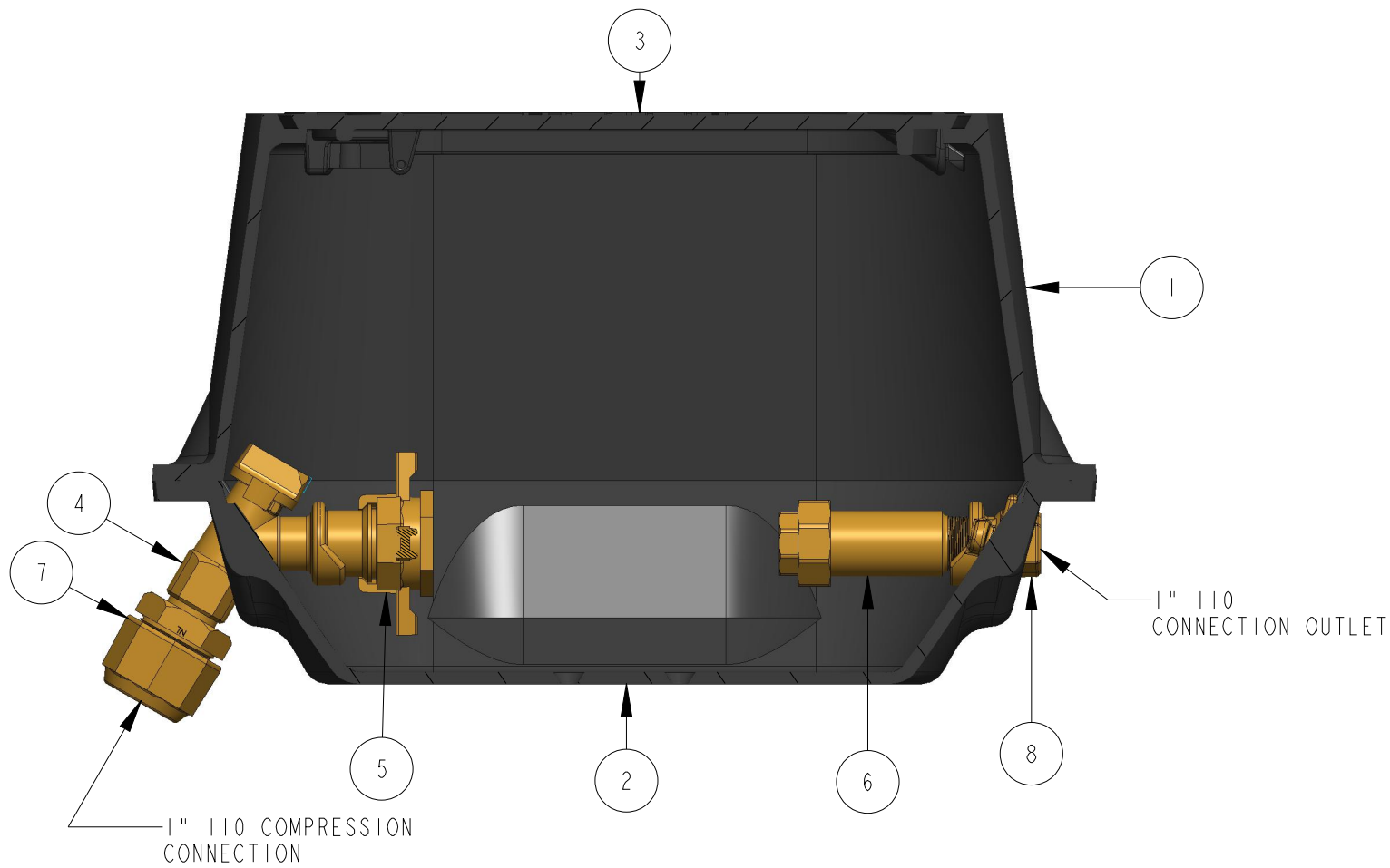

ITEM NO	PART NUMBER	QTY	DESCRIPTION	MATERIAL
1	311929_REVC	1	7" STRETCH BOX PLASTIC UPPER	HIGH DENSITY POLYETHYLENE - BLACK
2	532208_REV-C	1	STRETCH BASE TRAY CASTING	CAST IRON ASTM A48 CLASS 25
3	544862	1	6"X13" PLASTIC LID	ABS PLASTIC
4	089805N	1	5/8" X 3/4" OR 3/4" METER VALVE	LEAD FREE BRASS ALLOY ASTM B584 C89833/C87850
5	250HI4234N	1	3/4" HANDWHEEL EXPANSION	LEAD FREE BRASS ALLOY ASTM B584 C89833/C87850
6	311930E	1	Two-Stage Backflow-Prevention Valve	Low Lead Cast Bronze ASTM B 584
7	333HI5428N	1	1" CTS X 3/4" MIP SERVICE FITTING	LEAD FREE BRASS ALLOY ASTM B584 C89833/C87850
8	508563E	1	3/4" INSIDE IP THREAD OUTLET	LEAD FREE BRASS ALLOY ASTM B584 C89833/C87850



DR. BY	AOD	2/16/22	UNLESS OTHERWISE NOTED		THIRD ANGLE PROJECTION	C.B. NO.
CHKR			BREAK CAST CORNER(S)---			
ENGR			BREAK MACH CORNER(S)---			PURCH.
MGR			TOLERANCES		REF. NO.	PATT. NO.
MFG			UNLESS OTHERWISE NOTED		SCALE	
TOOL			LINEAR	ANGULAR	NONE	
FDRY			±	±	STK. NO.	
MAT'L:						
MUELLER		DESCR.	5/8"X3/4" CAST IRON STRETCH METER BOX LOW LEAD BRASS		NUMBER	234HI46IPPJ---N

234HI46IPPJ---N