

ITEM NO	PART NUMBER	QTY	DESCRIPTION
1	504041	4	HEX CAP SCREW
2	532208_REV-C	1	STRETCH BASE TRAY CASTING
3	532209_REV-B	1	STRETCH BOX UPPER SECTION
4	544622	4	MACHINE SCREW
5	544623	4	HEX NUT
6	544631	4	1/4" LOCK WASHER 304SS
7	089805N	1	5/8" X 3/4" OR 3/4" METER VALVE
8	250H14234N	1	3/4" HANDWHEEL EXPANSION
9	333H15429N	1	1" X 3/4" SERVICE FITTING
10	508563E	1	3/4" INSIDE IP THREAD OUTLET

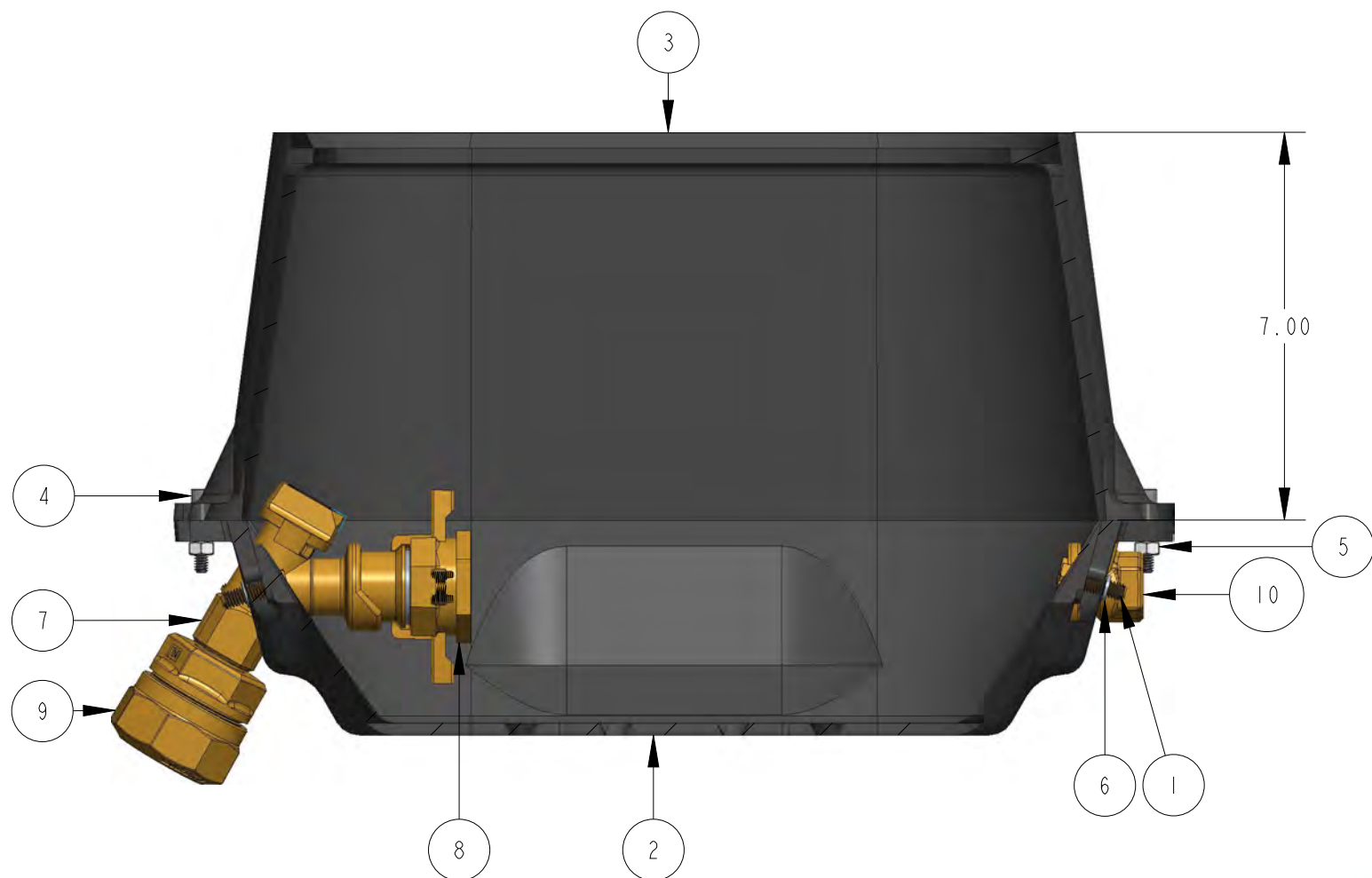

OPTION CODE 7:
*LESS METER BOX LID

DR. BY	AOD	8/18/22	UNLESS OTHERWISE NOTED		THIRD ANGLE PROJECTION		C.B. NO.
CHKR			BREAK CAST CORNER(S)---				
ENGR			BREAK MACH CORNER(S)---		PURCH.	FINISH	PATT. NO.
MGR			TOLERANCES		REF. NO.	SCALE	
MFG			UNLESS OTHERWISE NOTED		STK. NO.	NONE	
TOOL			LINEAR	ANGULAR			
FDRY			±	±			

MAT'L:		DESCR. 5/8" X 3/4" CAST IRON METER BOX 7" HEIGHT LOW LEAD BRASS		NUMBER 234H1462--M-7-N
MUELLER				

234H1462--M-7-N