

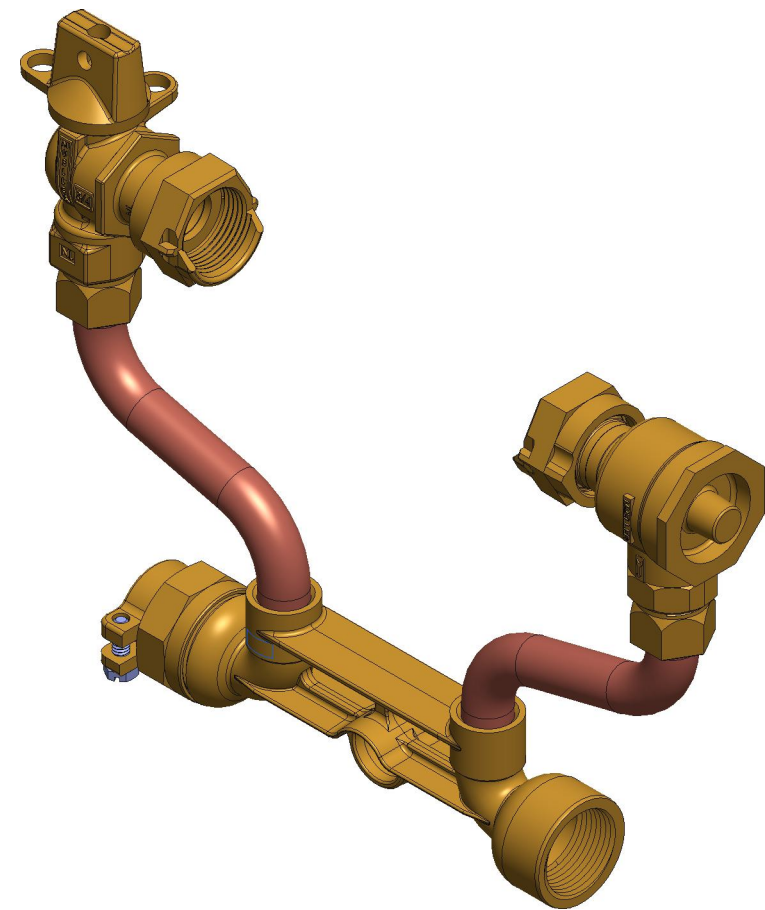

ITEM NO	PART NUMBER	QTY	DESCRIPTION	MATERIAL
1	681922	1	1" CTS PACK JOINT	LEAD FREE BRASS ALLOY ASTM B584 C89833/C87850
2	01424451__215N	1	5/8" X3/4" DUAL CHECK VALVE	LEAD FREE BRASS ALLOY ASTM B584 C89833/C87850
3	02426551R_215N	1	5/8" X 3/4" REDUCED PORT BALL VALVE	LEAD FREE BRASS ALLOY ASTM B584 C89833/C87850
4	532286E	1	5/8" & 5/8"X3/4" 110 COMP X FIP METER BAR	LEAD FREE BRASS ALLOY ASTM B584 C89833/C87850
5	680001E	2	RISER SUB ASSEMBLY	COPPER ALLOY C12200

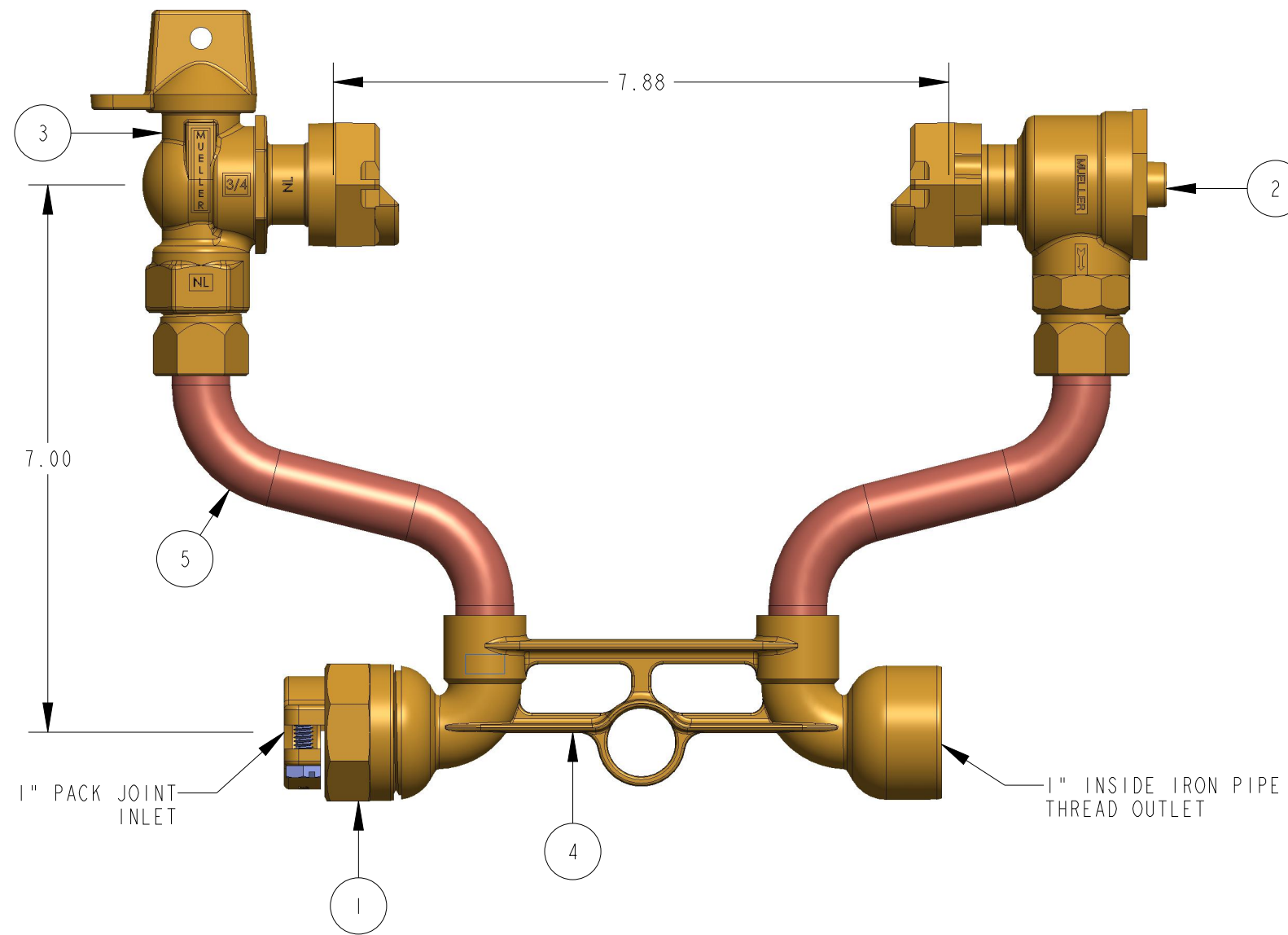

INTERPRET THIS DRAWING IN ACCORDANCE WITH ASME Y14.5 2018 UNLESS OTHERWISE SPECIFIED DIMENSIONS ARE IN INCHES. MACHINING TOLERANCES: X ±.1 XX ±.015 XXX ±.005 ANGULAR CORNER BREAK FINISH ±1° .015/.025 125 µin. RA	NAME	DATE	THIRD ANGLE PROJECTION  MUELLER TITLE: 5/8"X3/4" COPPER METER SETTER 7" RISER HEIGHT LEAD FREE BRASS	
	DRAWN BY	AOS		June-07-22
	D.E. APPR.			
	M.E. APPR.			
	Q.A. APPR.			
DO NOT SCALE DRAWING				
MATERIAL:	SIZE	DWG. NUMBER	REV	
STK NUMBER:	B	234P24981R2—N	B	
REF.NO.	SCALE: 0.200	WT:	SHEET 1 OF 1	

REVISIONS					
REV	ECR	DESCRIPTION	DRAWN BY	DATE	APPROVED
B		UPDATED FORMAT ADDED MATERIAL INFORMATION	AOS	5/04/26	

TITLE TO AND OWNERSHIP OF THIS ENGINEERING DATA REMAINS IN Mueller Co. ASSENT ON THE PART OF THE RECIPIENT TO THESE CONDITIONS IS PRESUMED.